



**BEARING NUMBERING SYSTEM
for PRECISION ROLLING
BEARINGS**

(INTERCHANGE)



Previous Interchange Table

Interchange Table for:

NACHI High Speed Angular Contact Ball Bearing

BNH Series

<< **INTERCHANGE TABLE - Suffix & Prefix** >>

Precision Rolling Bearings:

	NACHI	SKF	FAG	FAFNIR	BARDEN	N
Dimensional Series						
ISO 19	7900	71900	71900	9300	1900	7900
ISO 10	7000	7000	7000	9100	100	7000
ISO 02	7200	7200	7200	200	200	7200
Precision Classes						
ABEC 5	P5	P5	P5	* V	5P	P5, PA
ABEC 7	P4	P4	P4	* MV, MM	7T	P4, PA
ABEC 9	P2	P29A	P2	* MMX	9P	P2, PA
Contact Angles						
				**by series		
15°	C	C	C	* 2	100, 200, ZSB100, 190	C
30°	A	A, AC (25°)	E (25°)	* 3 (25°)	2100, 2200, ZSB200	A, A5
40°	B	B	B	WN		B
60°						
Preload						
Extra Light	GE	GO	UO	UX, DUX		C2
Light	GL	GA, DGA	UL	UL, L, DUL	DL, L	L, C7
Medium	GM	GB, DGB	UM	UM, M, DUM	DM, M	M, C8,
Heavy	GH	GC, DGC	US	UH, H, DUH	DH, H	H, C9,

BNH 000 Series (Dimension series 10)

NACHI	NSK	NTN	KOYO	BAR
BNH007T	35BNC10	BNT007	ACH007C	ZSB
BNH008T	40BNC10	BNT008	ACH008C	ZSB
BNH009T	45BNC10	BNT009	ACH009C	ZSB
BNH010T	50BNC10	HSB010C	ACH010C	ZSB
BNH011T	55BNC10	HSB011C	ACH011C	ZSB
BNH012T	60BNC10	HSB012C	ACH012C	ZSB
BNH013T	65BNC10	HSB013C	ACH013C	ZSB
BNH014T	70BNC10	HSB014C	ACH014C	ZSB
BNH015T	75BNC10	HSB015C	ACH015C	ZSB
BNH016T	80BNC10	HSB016C	ACH016C	ZSB
BNH017T	85BNC10	HSB017C	ACH017C	ZSB
BNH018T	90BNC10	HSB018C	ACH018C	ZSB
BNH019T	95BNC10	HSB019C	ACH019C	ZSB
BNH020T	100BNC10	HSB020C	ACH020C	ZSB
BNH021T	105BNC10	HSB021C	ACH021C	ZSB
BNH022T	110BNC10	HSB022C	ACH022C	ZSB

Interchange Table for: **NACHI Ball Screw Support Bearings**

NACHI	SKF	RHP	FAFNIR	BARDEN	NSK	NTN	KOYO
15TAB04	-----	-----	-----	-----	-----	-----	-----
17TAB04	-----	-----	MM17BS47	-----	17TAC47B	BST17x47-1	SAC1747
20TAB04	BDAB634207	BSB020047	MM20BS47	L2047H	20TAC47B	BST20x47-1	SAC2047
25TAB06	BDAB634208	BSB025062	MM25BS62	L2562H	25TAC62B	BST25x62-1	SAC2562
30TAB06	BDAB634209	BSB030047	MM30BS62	L3062H	30TAC62B	BST30x62-1	SAC3062
35TAB07	BDAB634210	BSB035072	MM35BS72	L3572H	35TAC72B	BST35x72-1	SAC3572
40TAB07	BDAB634211	BSB040072	MM40BS72	L4072H	40TAC72B	BST40x72-1	SAC4072

Interchange table for:

NACHI Thrust Angular Contact Ball Bearings - TAH / TBH Series

$\alpha = 30^\circ$			$\alpha = 40^\circ$			
NACHI	NSK	KOYO	NACHI	NSK	NTN	KOYO
50TAH0TDB	50BATYDB	ACT010DB	50TBH0TDB	50BTTYDB	HTA010DB	ACT010BDB
55TAH0TDB	55BATYDB	ACT011DB	55TBH0TDB	55BTTYDB	HTA011DB	ACT011BDB
60TAH0TDB	60BATYDB	ACT012DB	60TBH0TDB	60BTTYDB	HTA012DB	ACT012BDB
65TAH0TDB	65BATYDB	ACT013DB	65TBH0TDB	65BTTYDB	HTA013DB	ACT013BDB
70TAH0TDB	70BATYDB	ACT014DB	70TBH0TDB	70BTTYDB	HTA014DB	ACT014BDB
75TAH0TDB	75BATYDB	ACT015DB	75TBH0TDB	75BTTYDB	HTA015DB	ACT015BDB
80TAH0TDB	80BATYDB	ACT016DB	80TBH0TDB	80BTTYDB	HTA016DB	ACT016BDB
85TAH0TDB	85BATYDB	ACT017DB	85TBH0TDB	85BTTYDB	HTA017DB	ACT017BDB





**NACHI
Angular Contact
Ball Bearings for
Spindles**

(INTERCHANGE)



NACHI Spindle Bearings

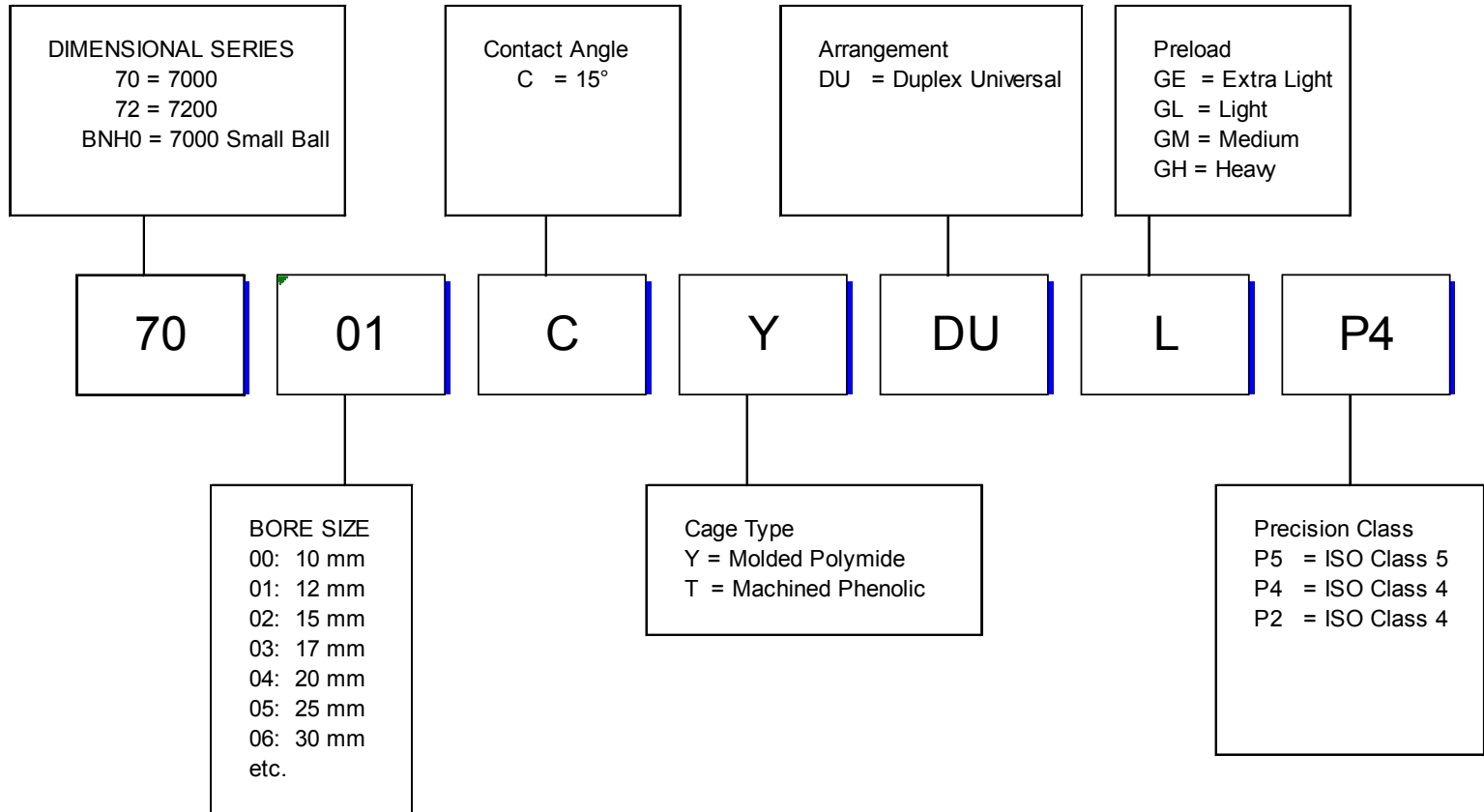

NSK Spindle Bearings

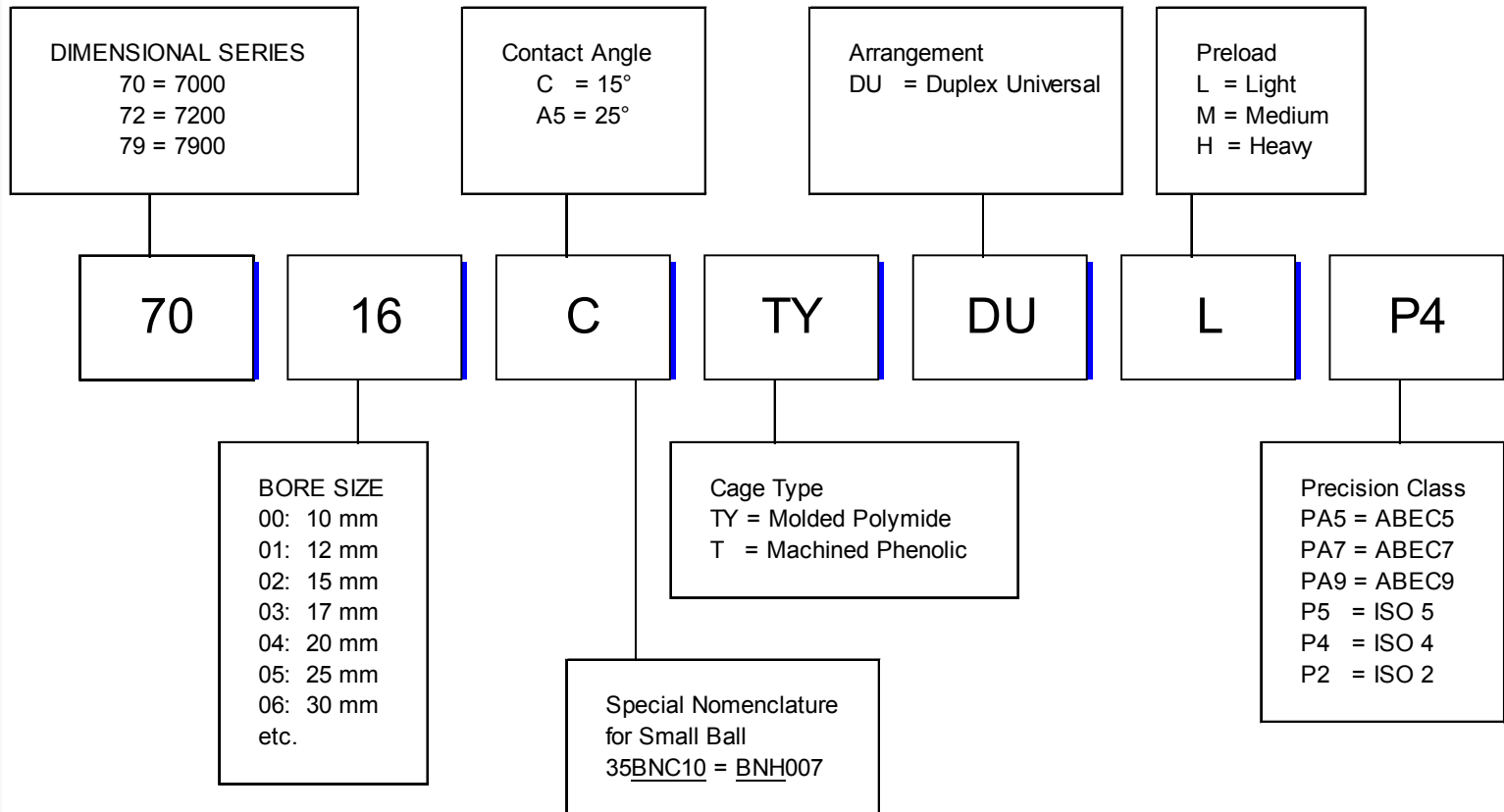

FAFNIR Spindle Bearing

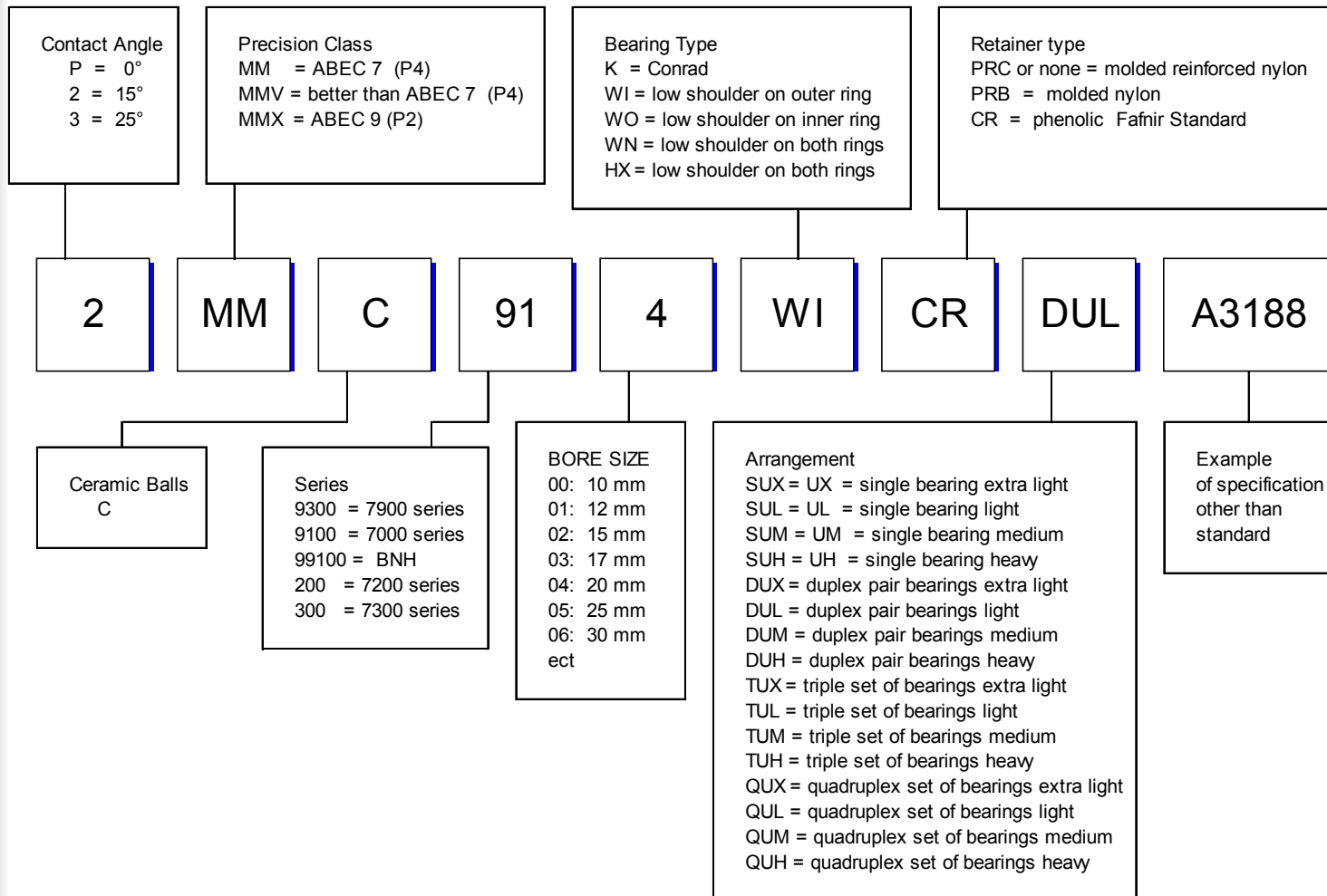

SKF Spindle Bearing

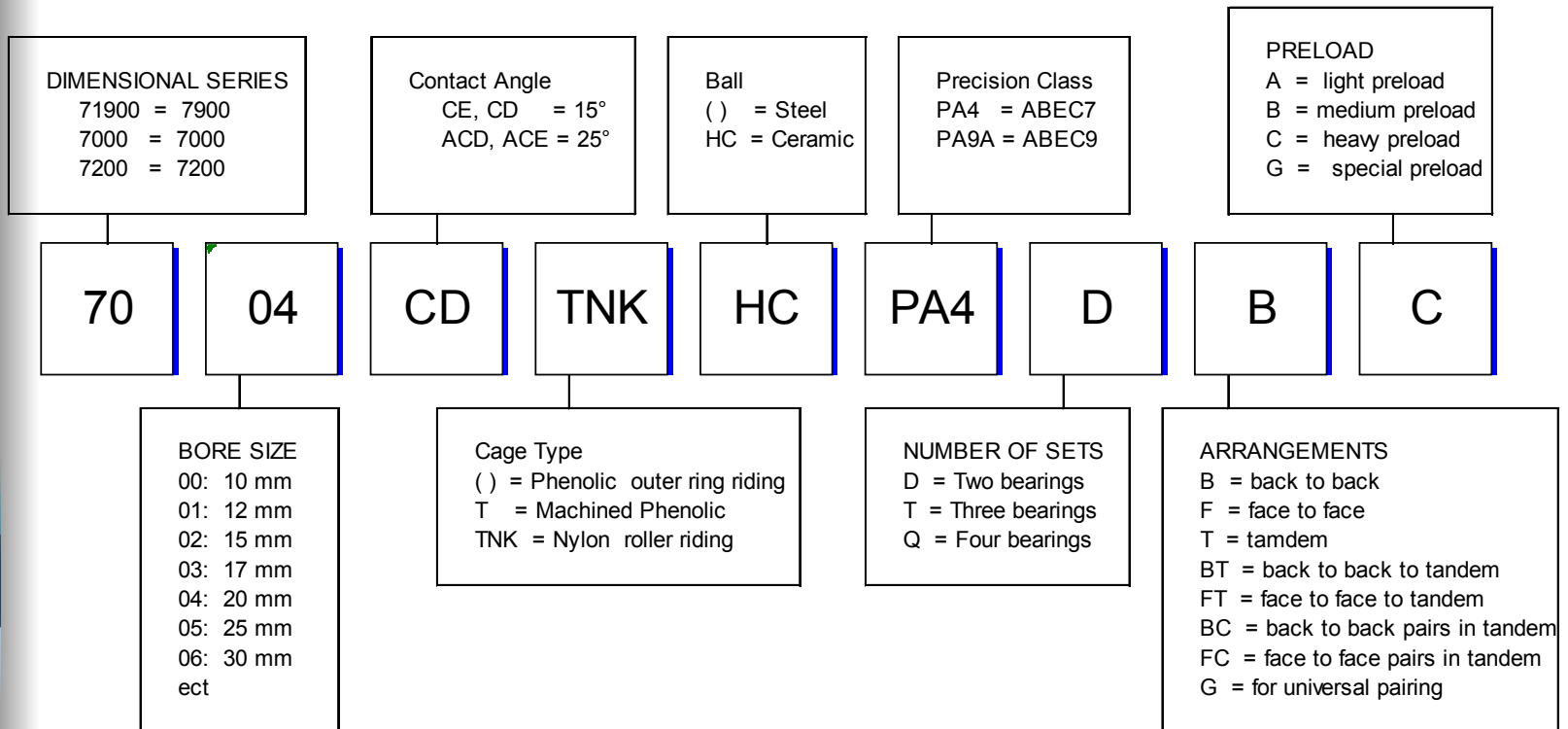

Barden Spindle Bearing

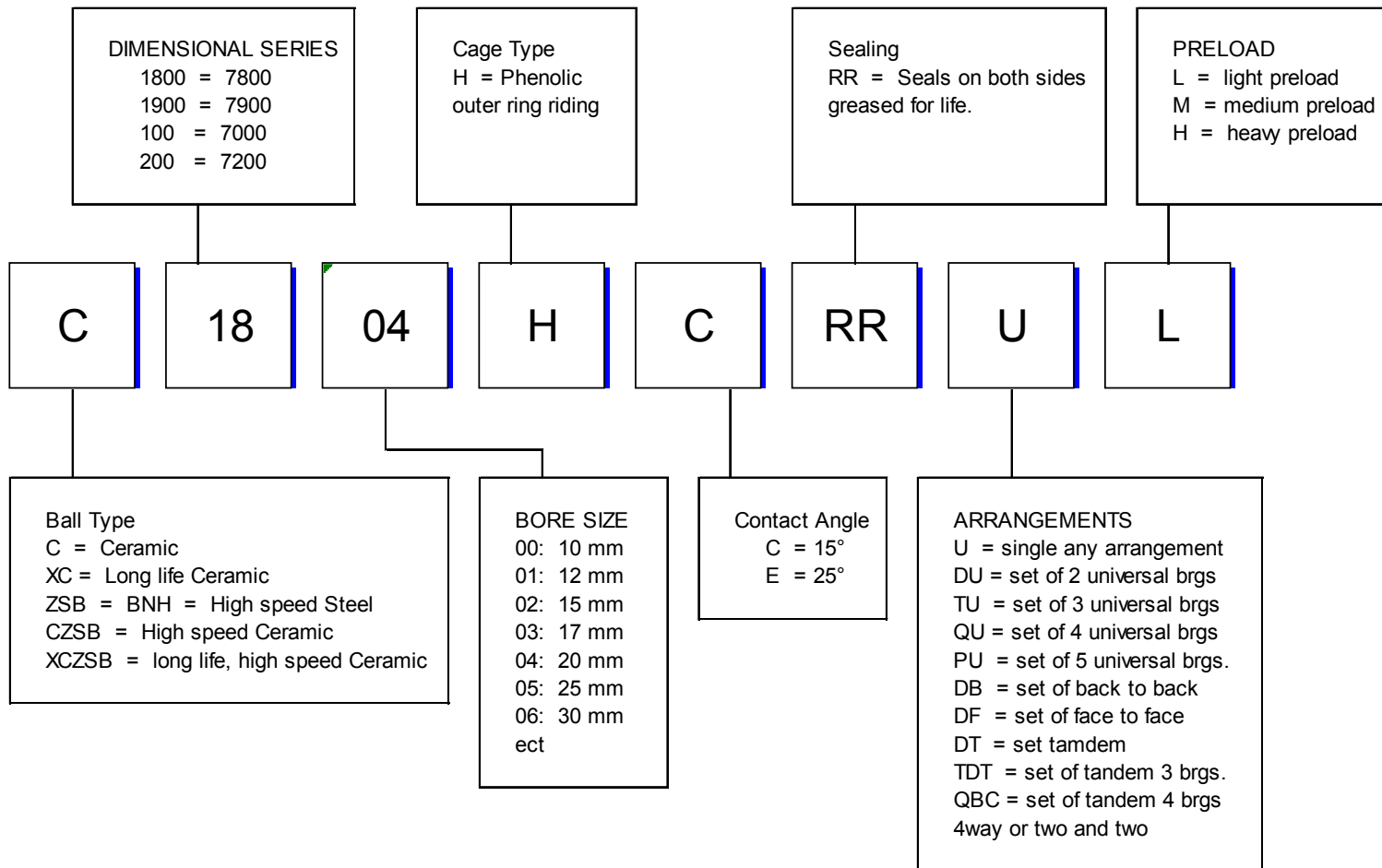

FAG Spindle Bearing

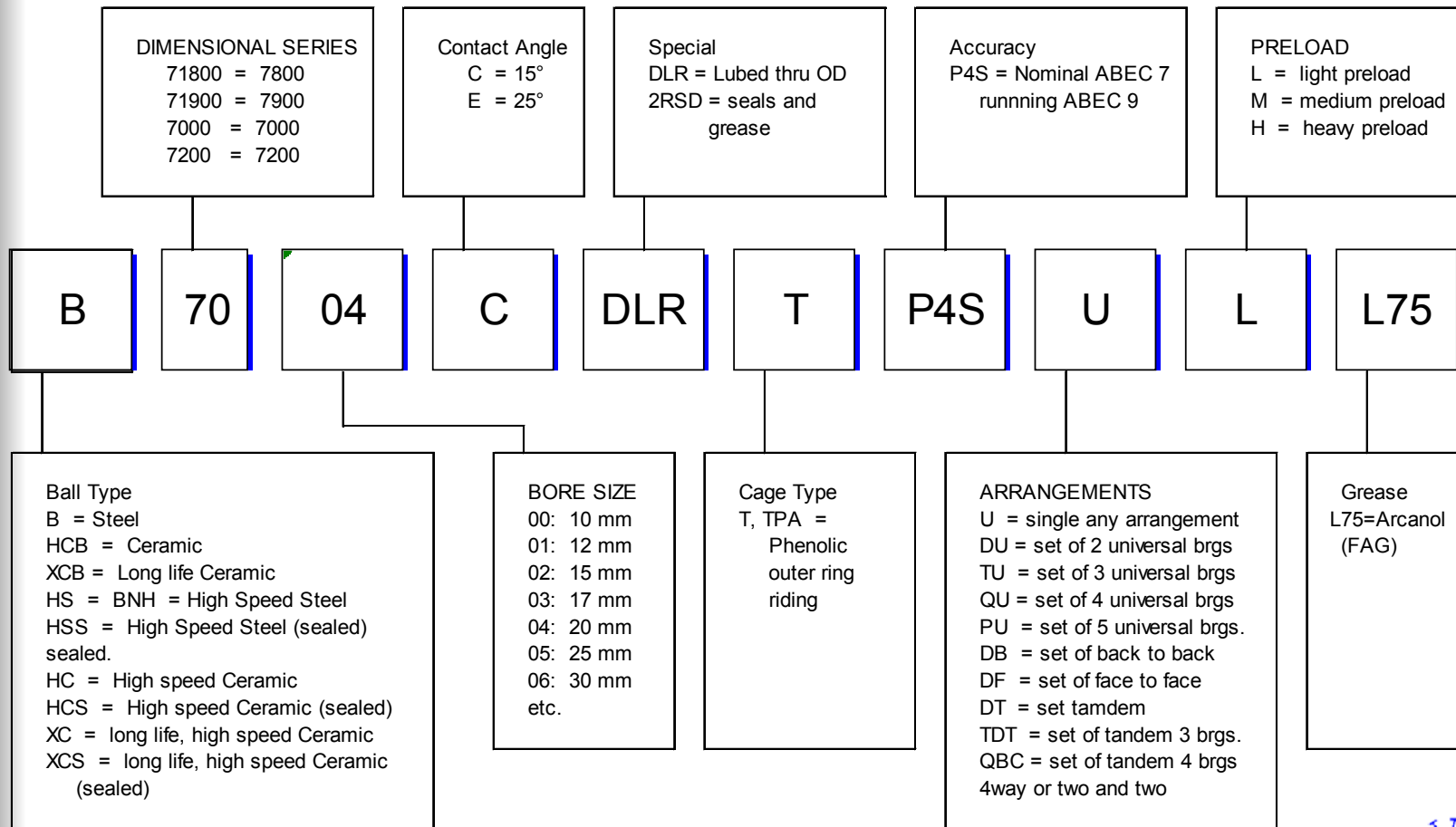

Koyo Spindle Bearing

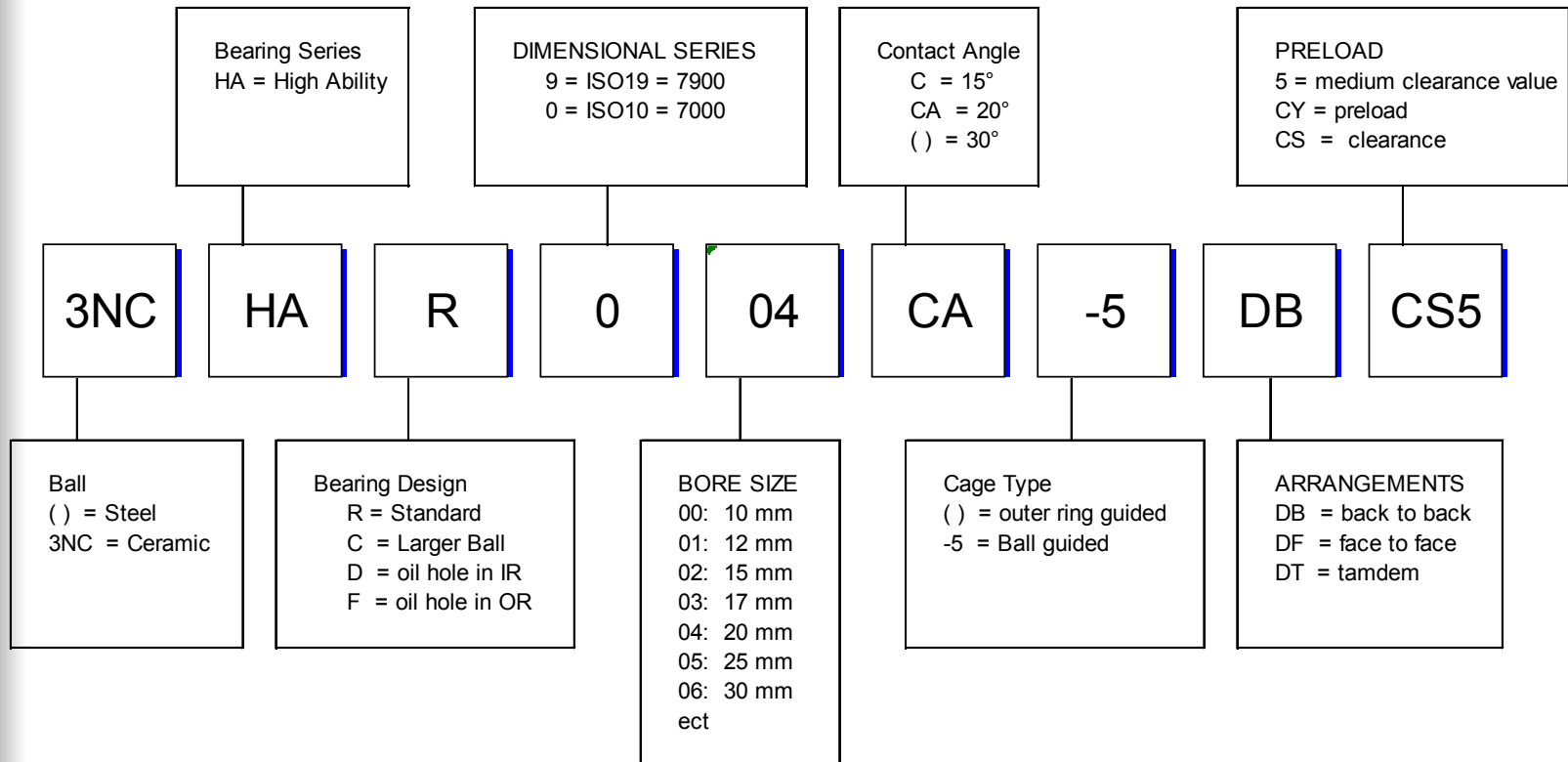

NTN Spindle Bearing

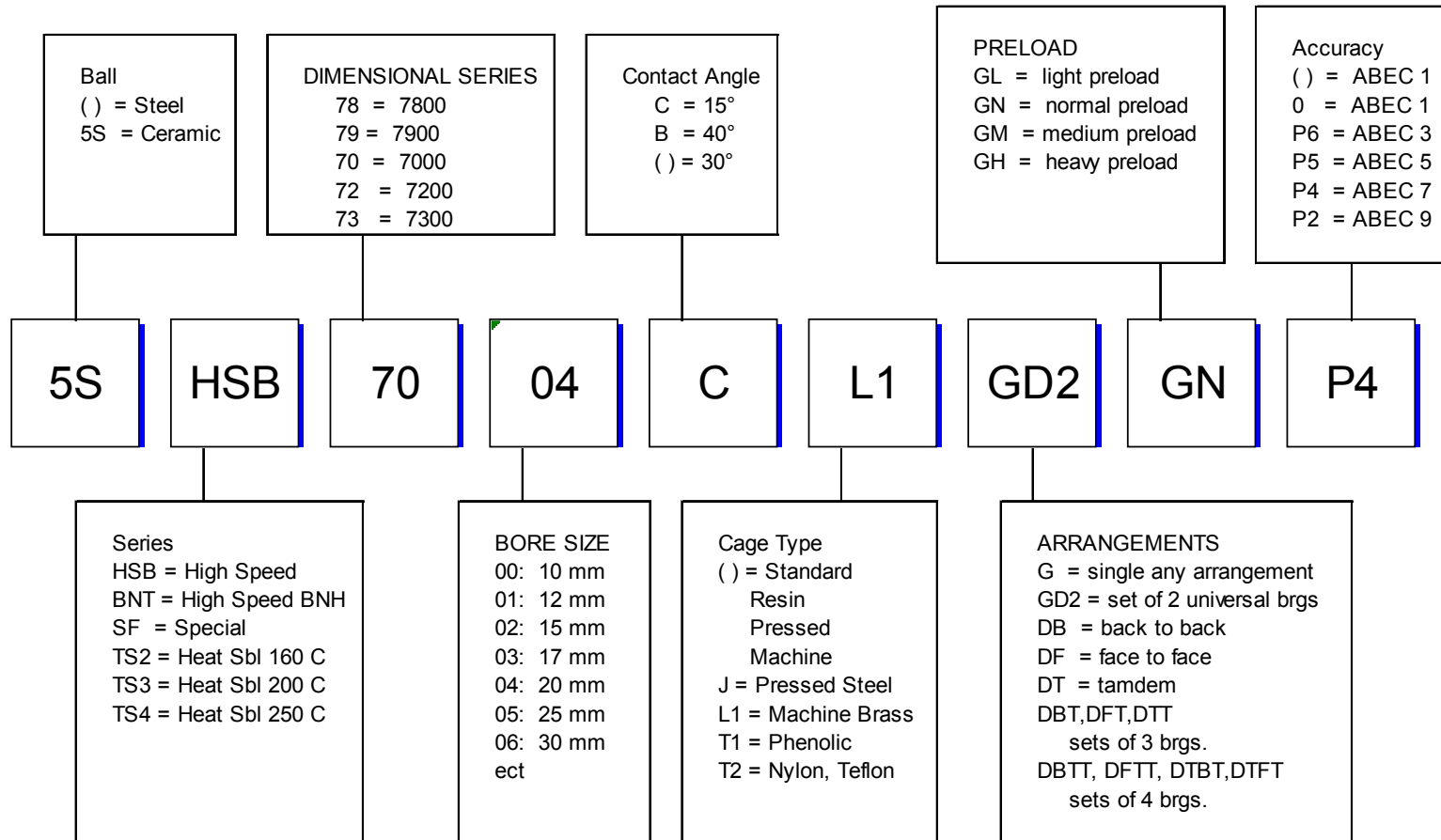



**NACHI
Ball Screw Support
Bearings**

(INTERCHANGE)



NACHI Ball Screw Support Bearing

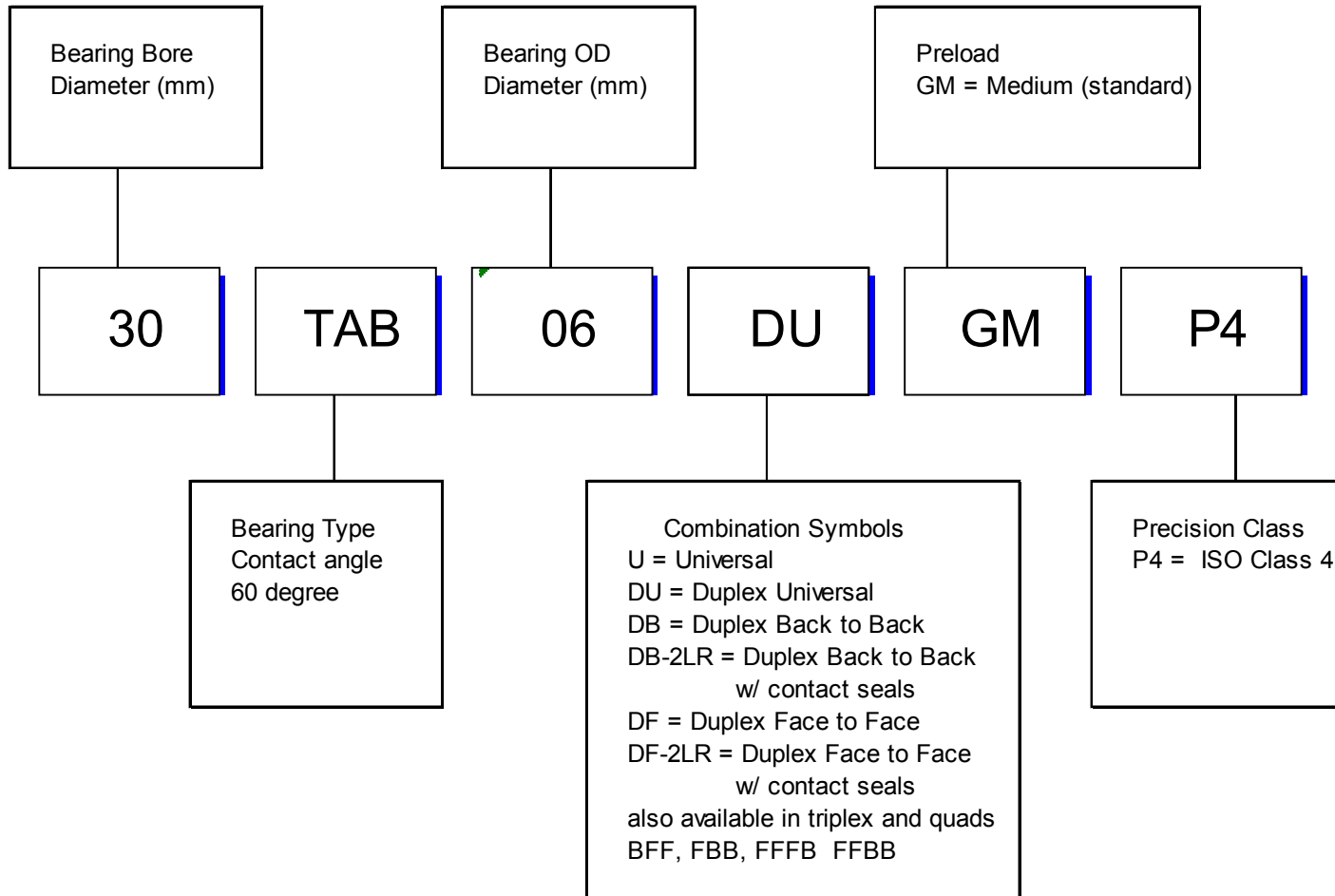

NSK Ball Screw Support Bearing

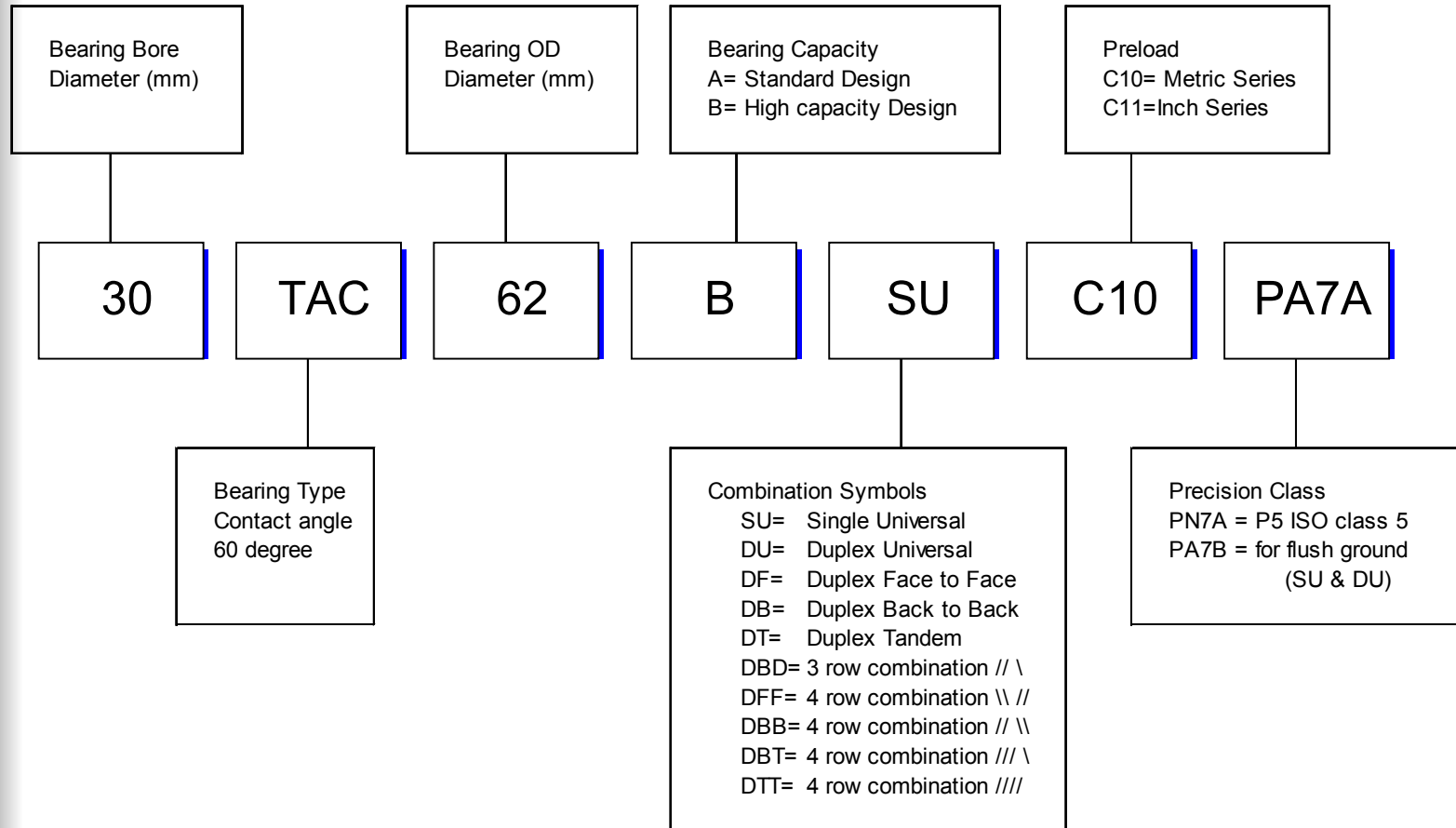

FAFNIR Ball Screw Support Bearing

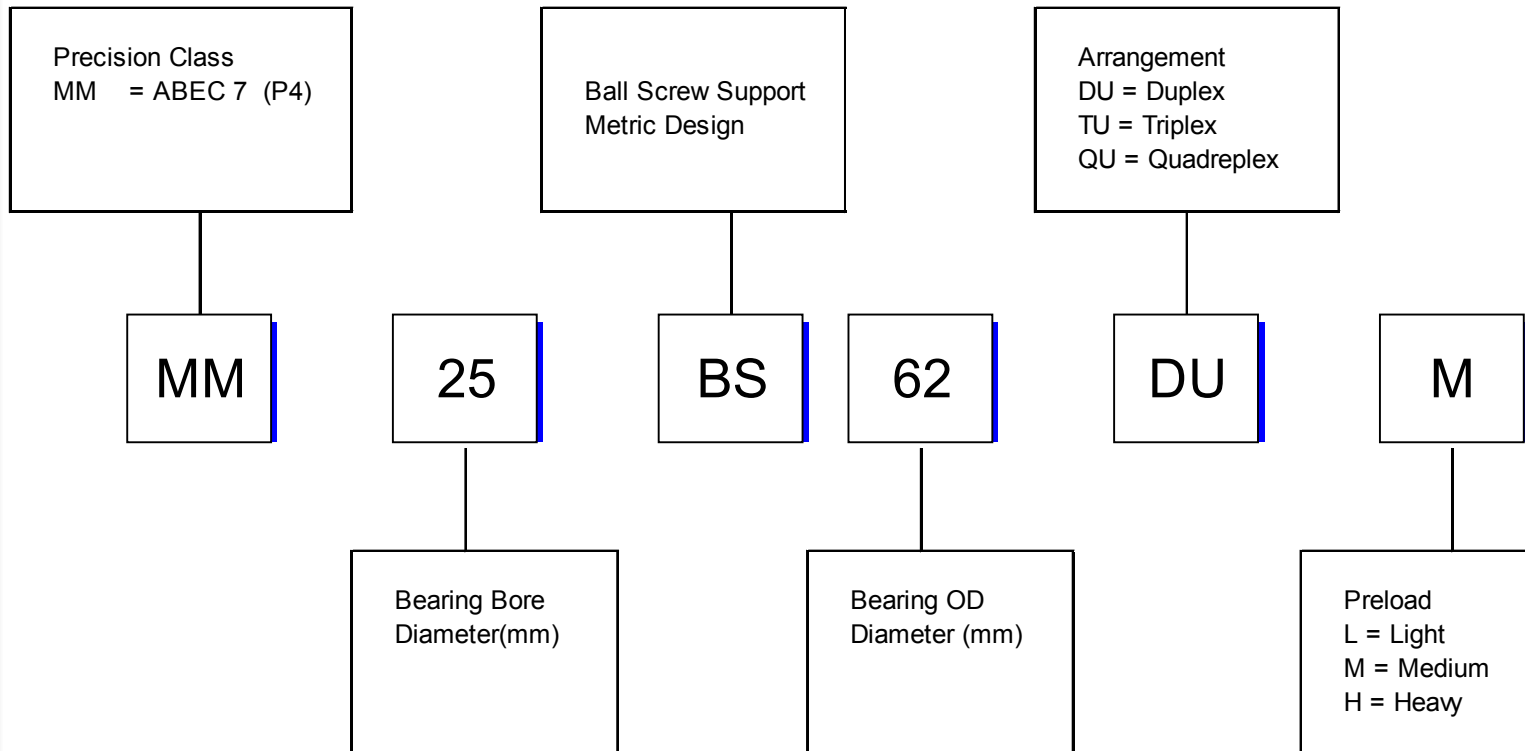

BARDEN-FAG Ball Screw Support Bearing

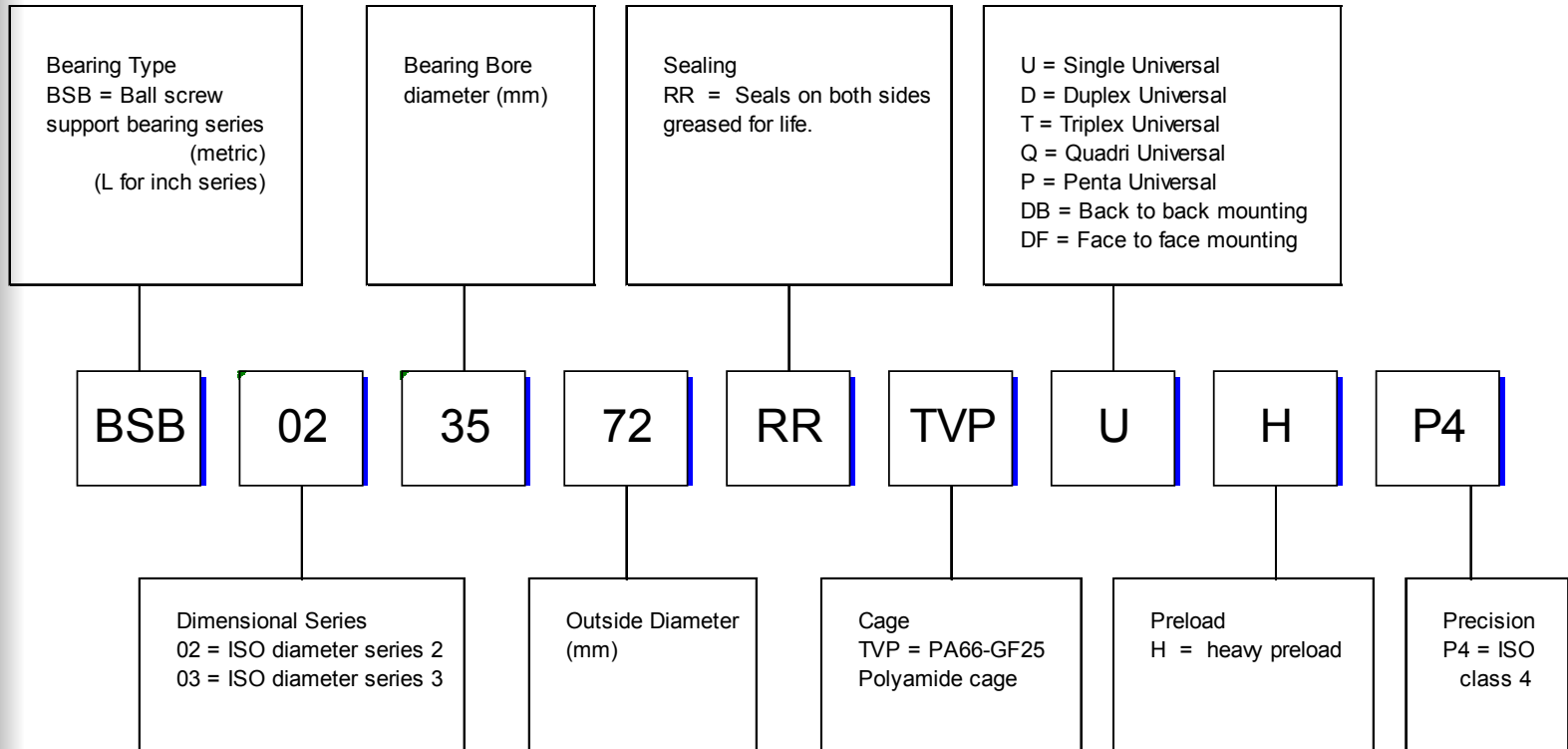

KOYO Ball Screw Support Bearing

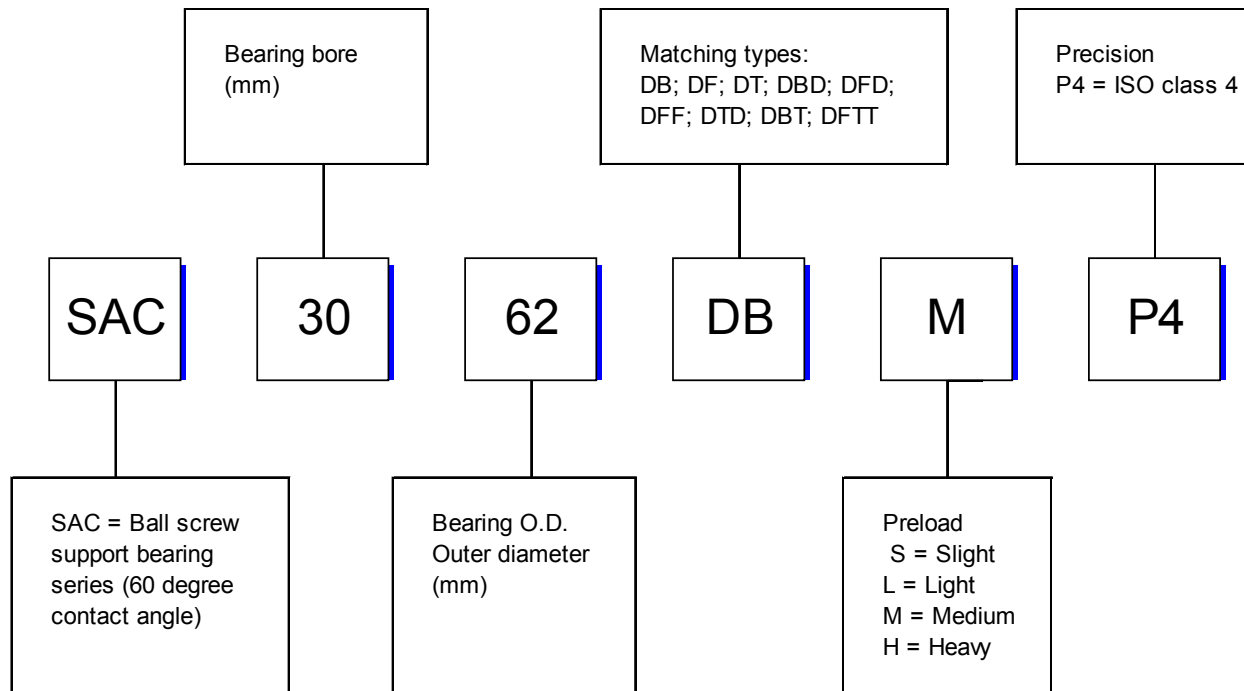



**NACHI
Double Row
Cylindrical Roller
Bearing
(INTERCHANGE)**



Nachi Cylindrical Spindle Bearings

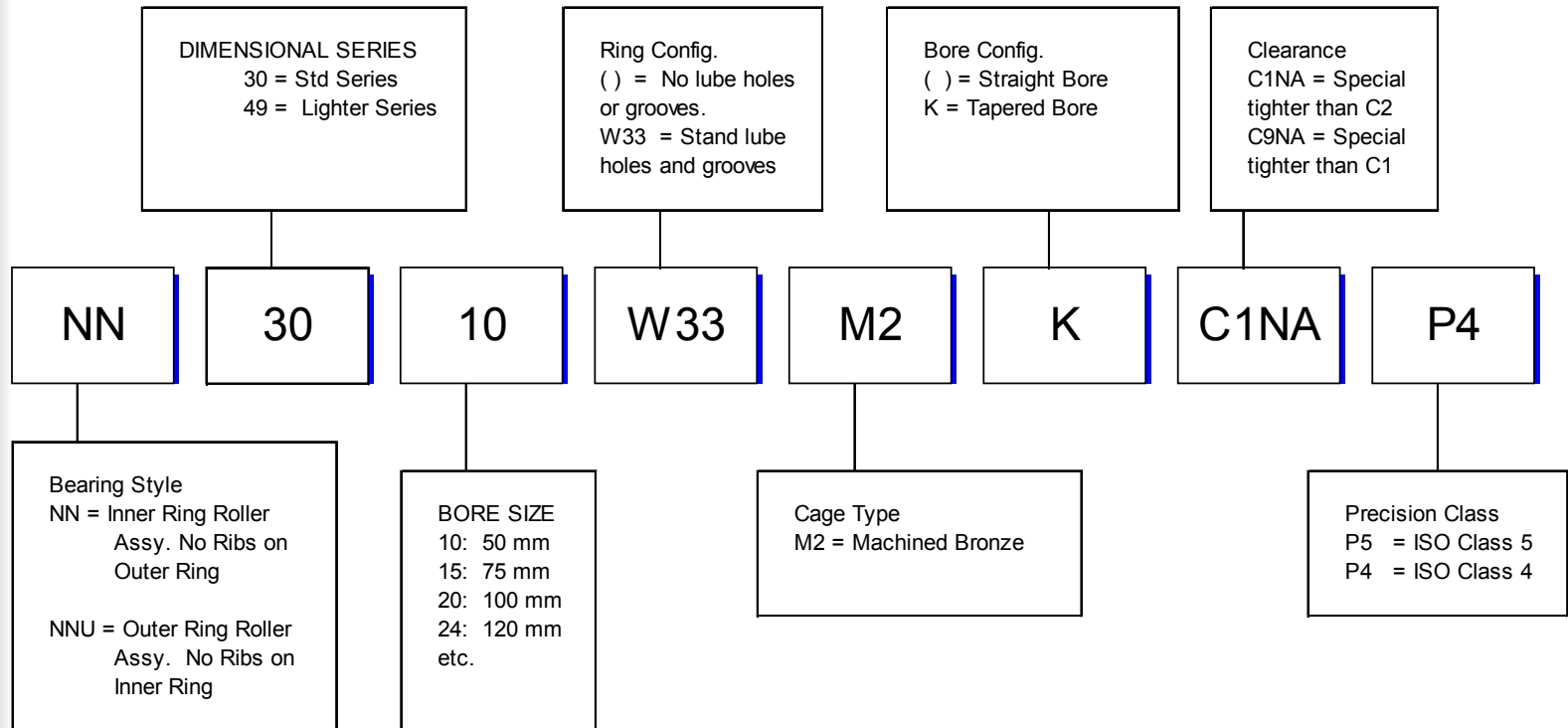

NSK Cylindrical Spindle Bearings

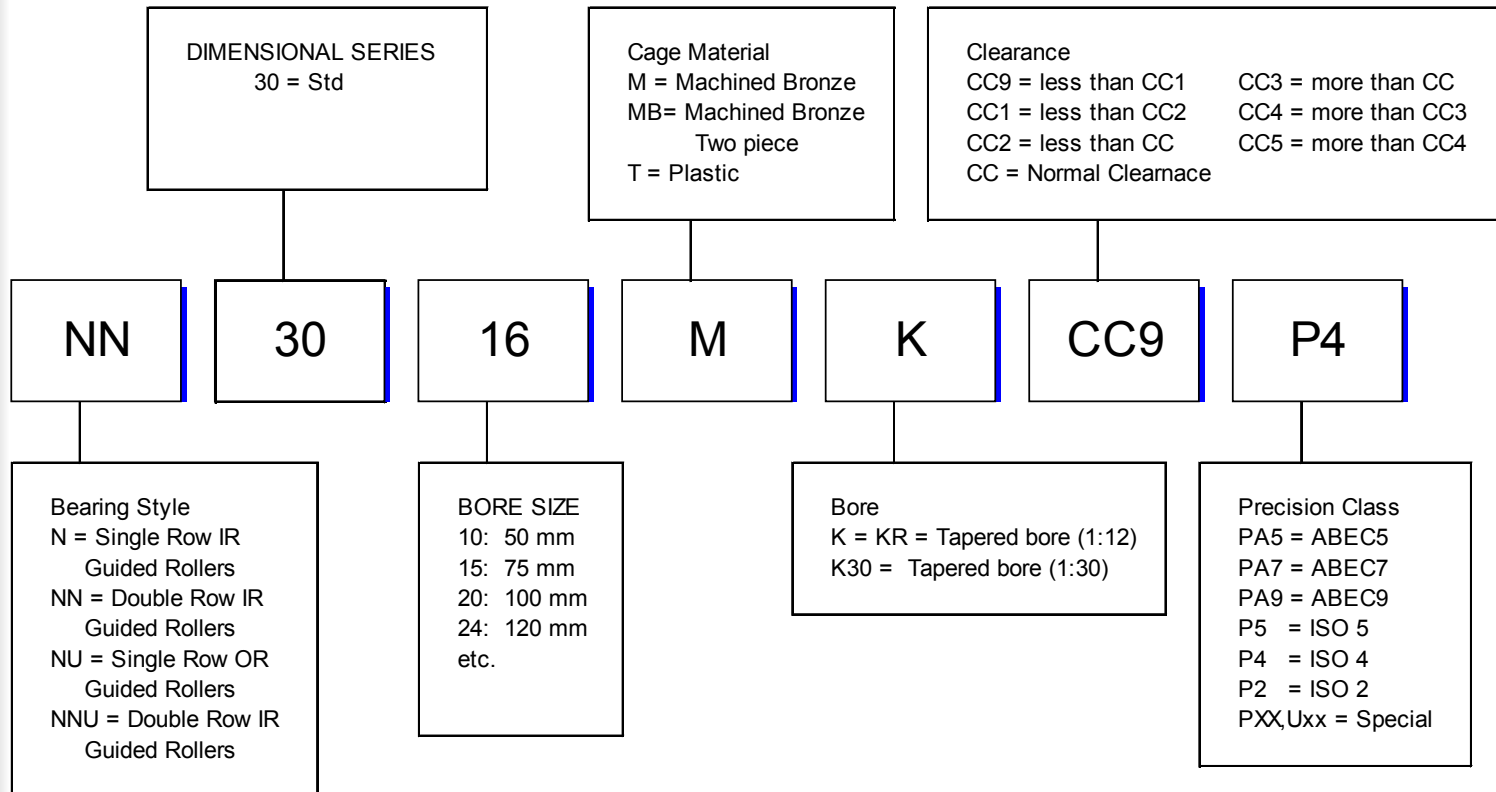

SKF Cylindrical Spindle Bearings

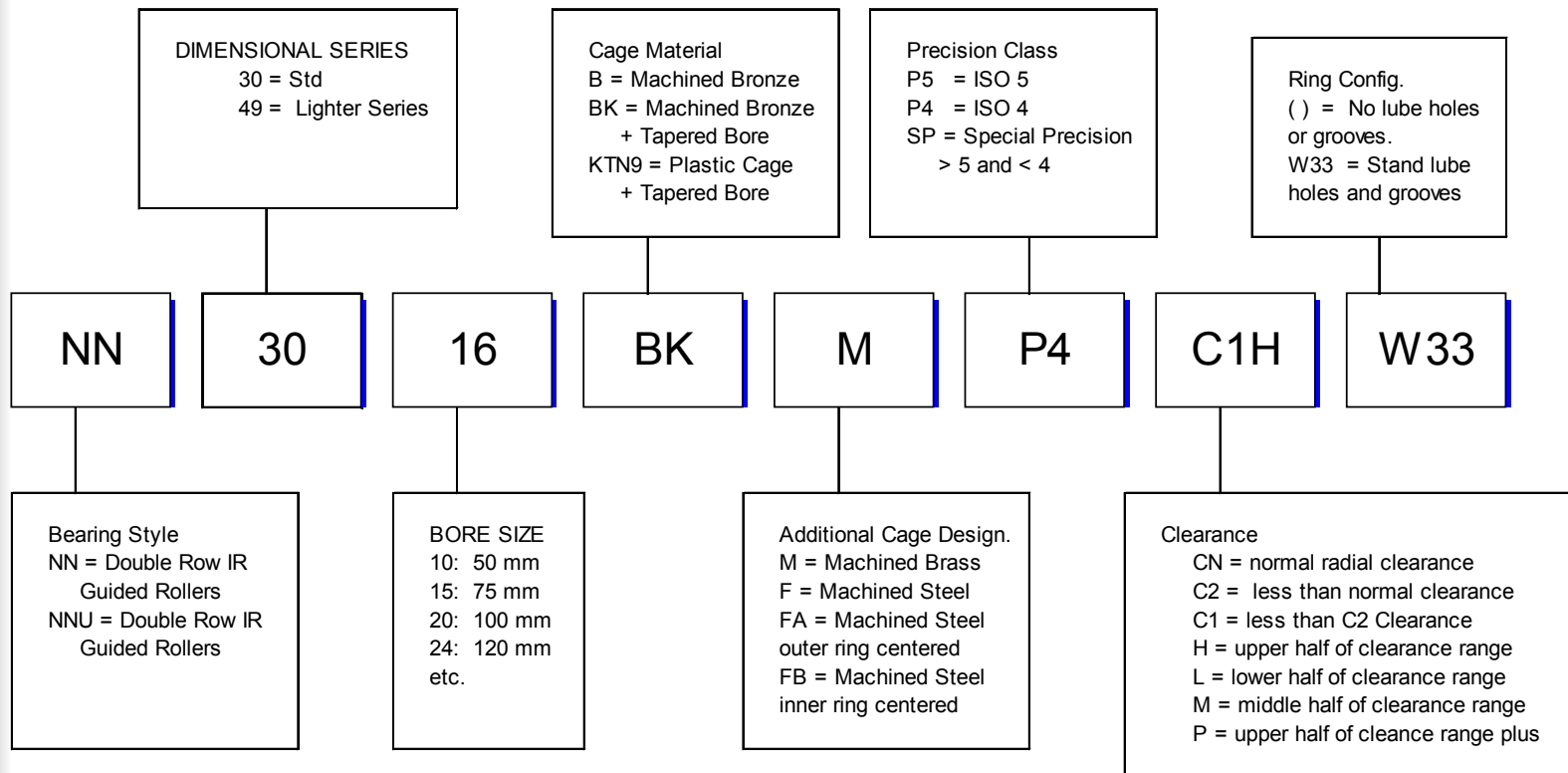

Barden/FAG Cylindrical Spindle Bearing

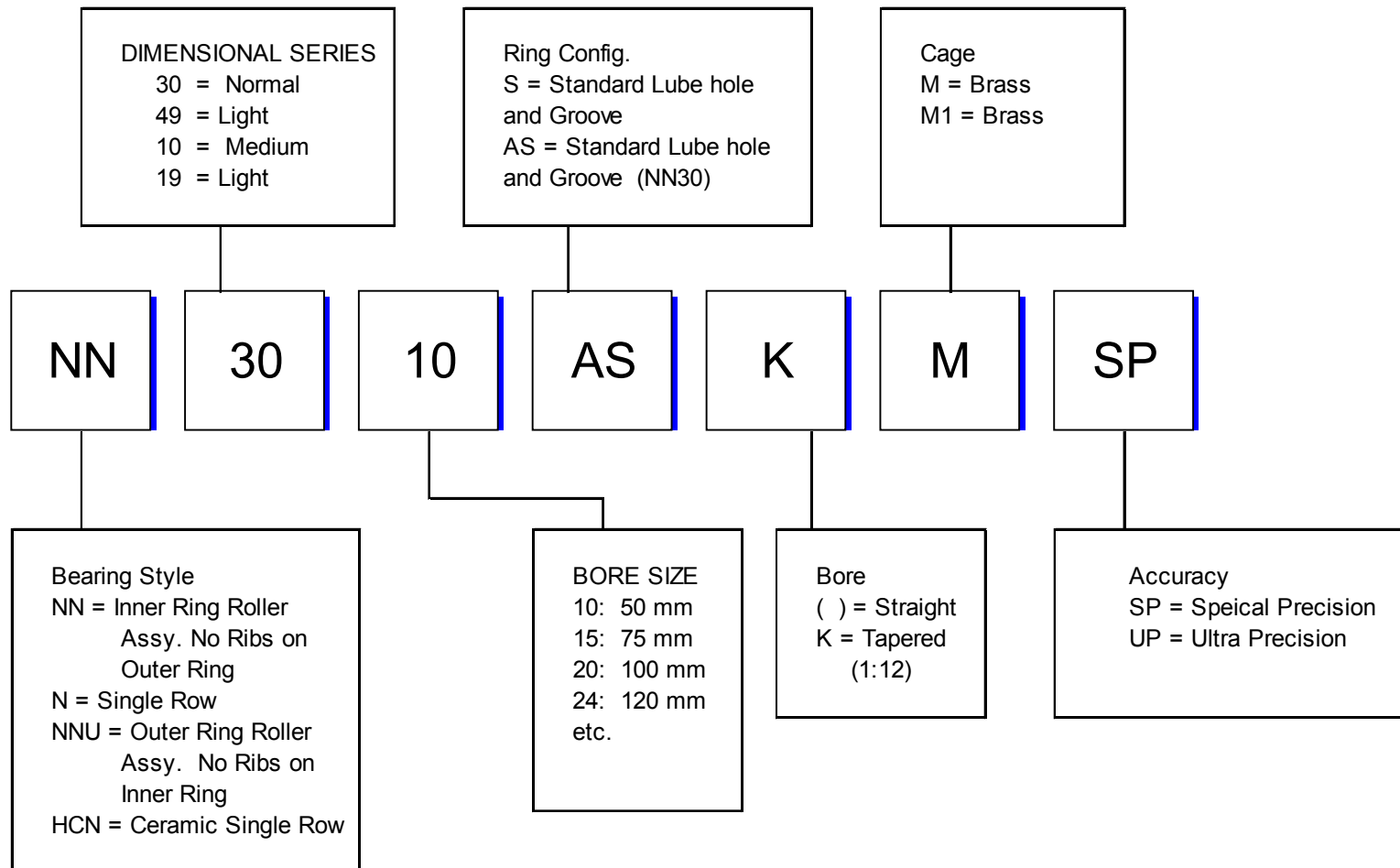

Koyo Cylindrical Spindle Bearings

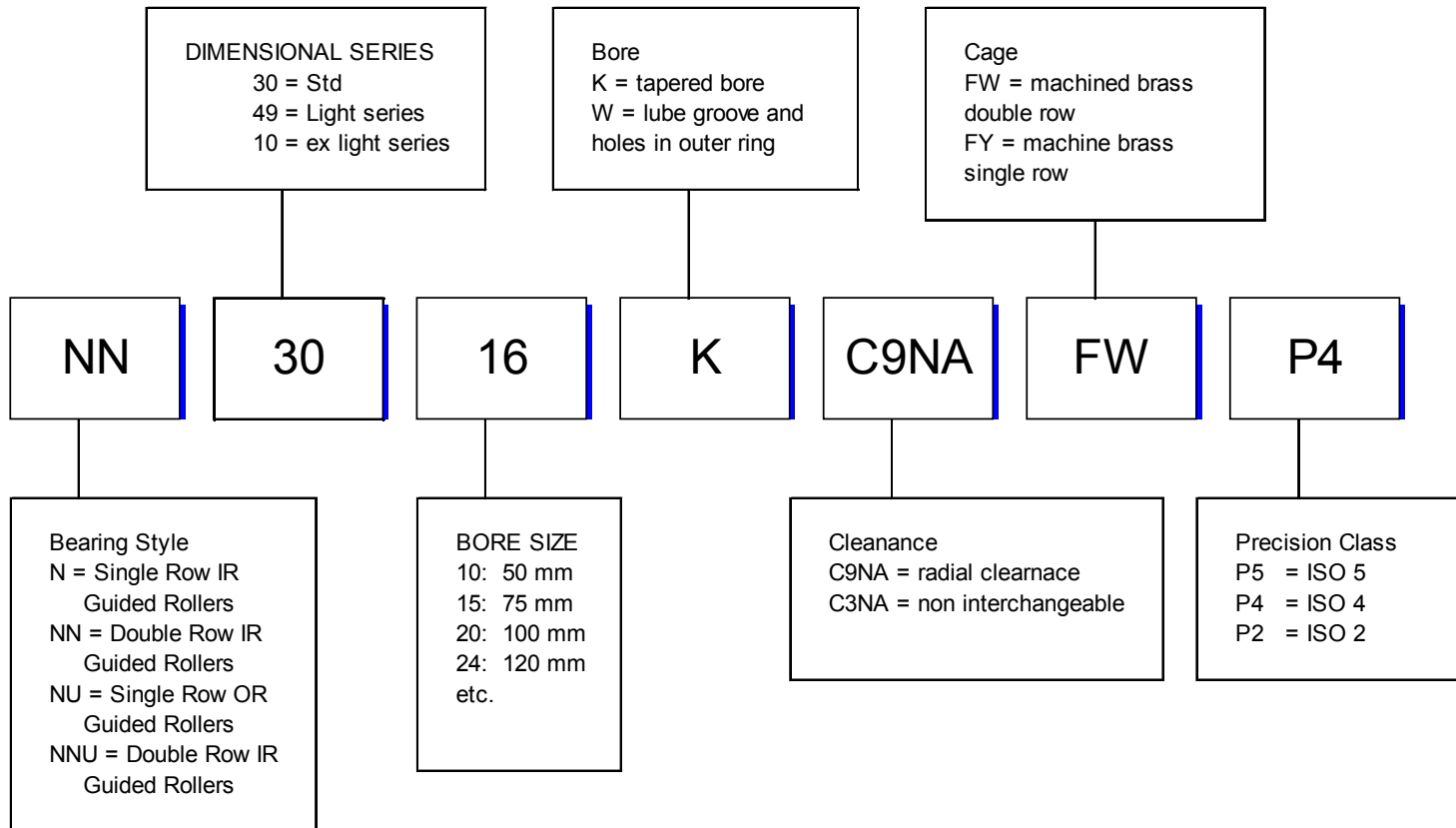

NTN Cylindrical Spindle Bearings

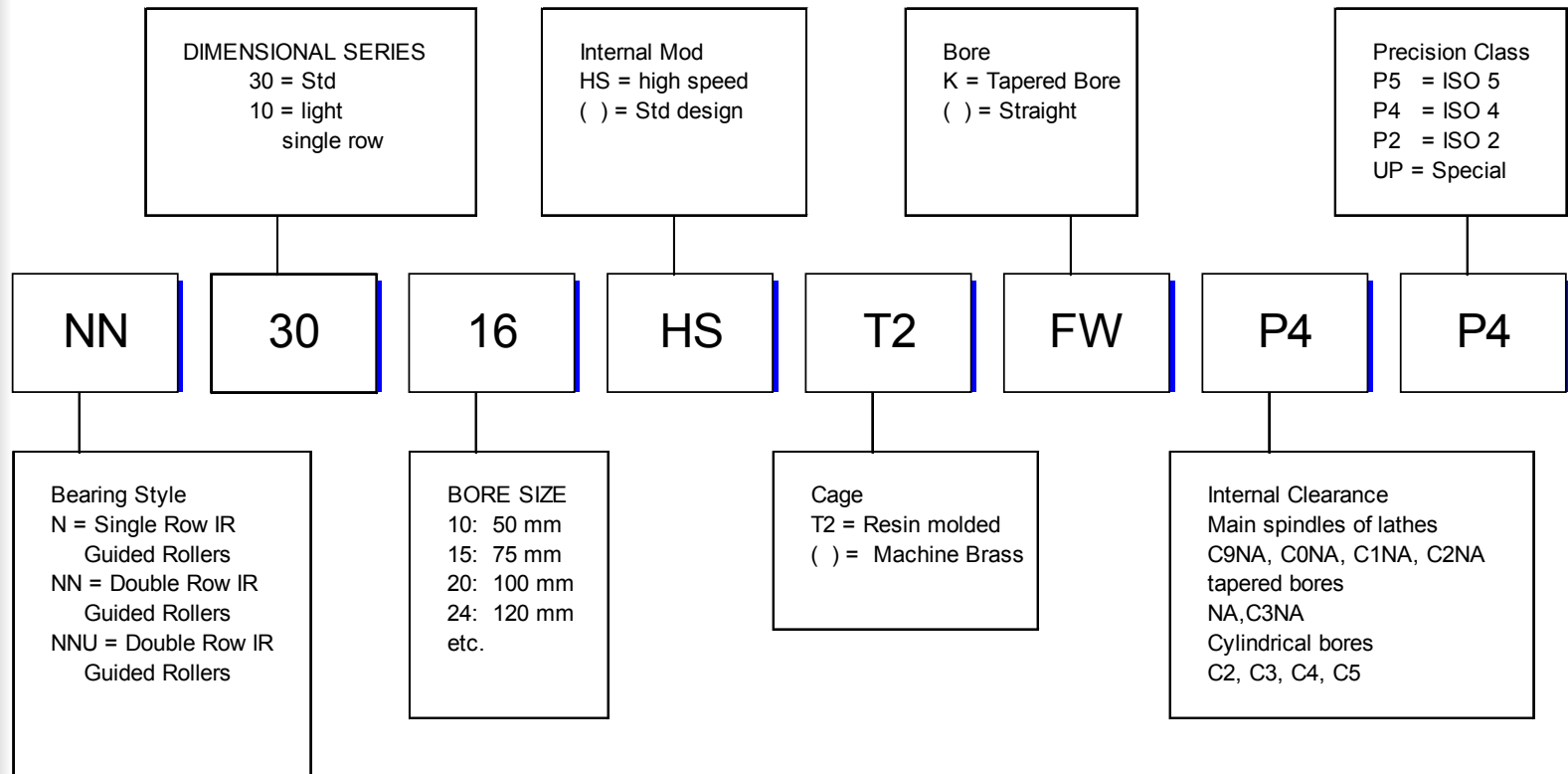

Nachi Thrust Bearings for Spindle Applications

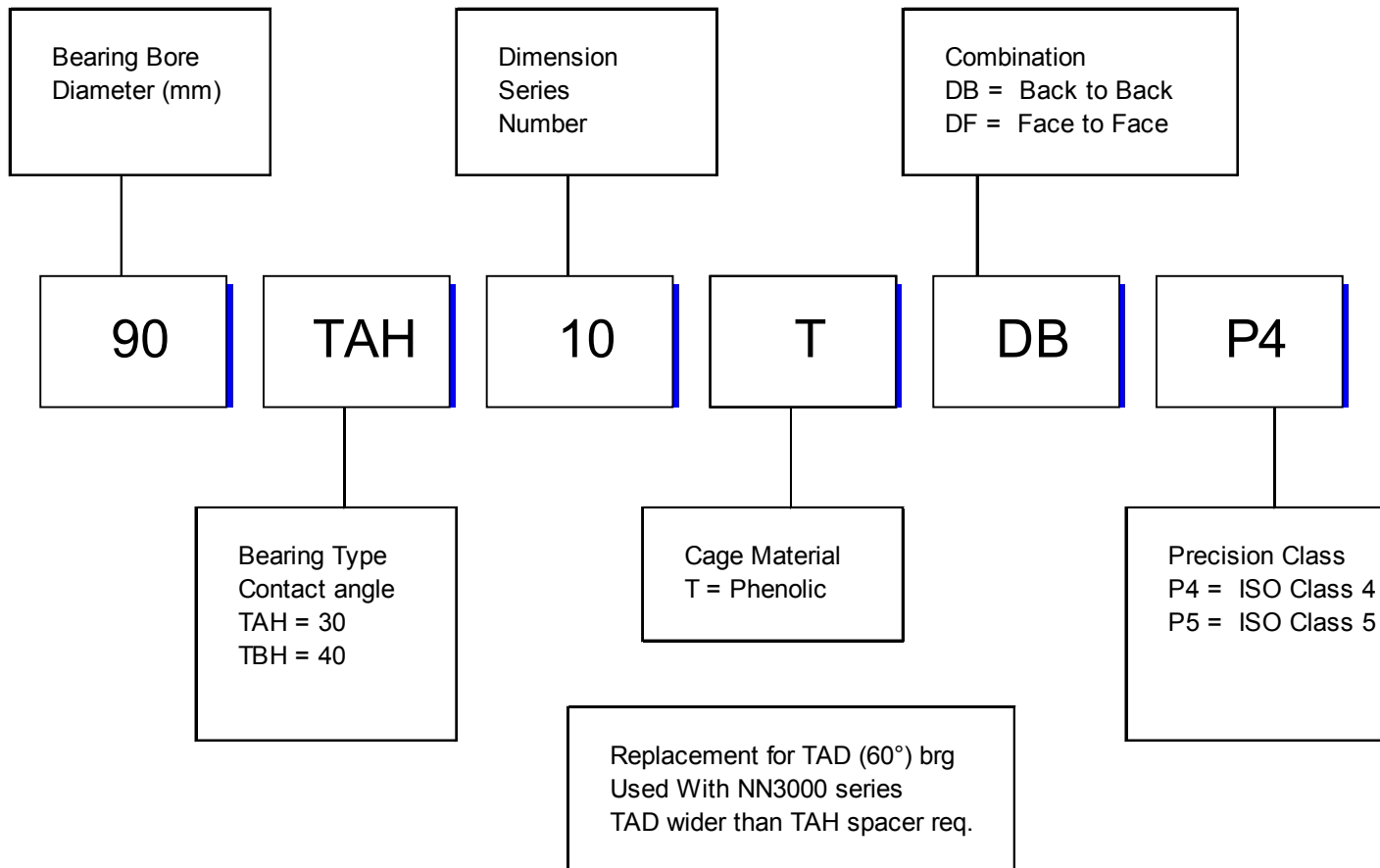

NSK Thrust Bearings for Spindle Applications

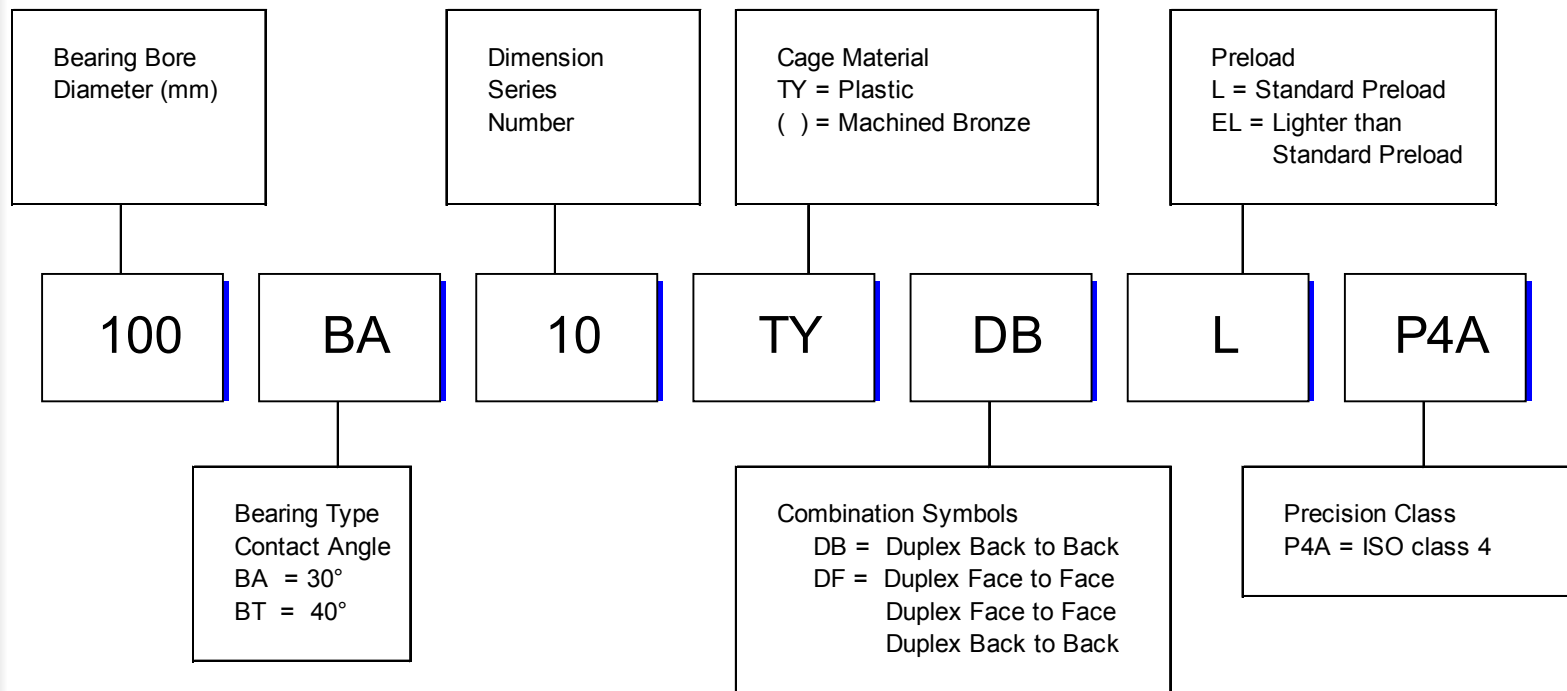

NTN Thrust Bearings for Spindle Applications

