

INTERCHANGEABLE BUSHINGS

PRODUCT	PAGE
INDEX	B-1
QD	
Installation/Removal	B-2
Steel Bushings	B-3
Standard Bushings	B-4
Weld-On Hubs	B-5
QD Short Bushings	B-6
TAPER BUSHINGS	
Installation/Removal	B-7
1008 — 3030	B-8
3535 — 5050	B-9
6050 — 120100	B-10
Weld-On Hubs	B-11
Reborable Bushings	B-12
MST® BUSHINGS	
Bushing Specifications	B-13
Installation & Removal	B-14
Weld-On Hubs	B-15
IDLER BUSHINGS; QD, MST®	B-16



Conmutador: +52(55) 5305-1320
Fax: +52(55) 5305-1326
Nextel ID: 52*40085*2
Lada sin Costo México: 01800 552 9428
mail: ventas@rodamientos-samper.com.mx

Stock QD Bushings



Martin MOUNTING PROCEDURE – QD BUSHINGS

IMPORTANT – BE SURE TAPERED CONE SURFACES OF QD BUSHING AND INSIDE OF SHEAVE OR SPROCKET HUB ARE DRY AND FREE OF ALL FOREIGN SUBSTANCES SUCH AS PAINT, GREASE, OR DIRT.

STANDARD Mounting Assembly FOR QD SHEAVES AND SPROCKETS

MOUNTING

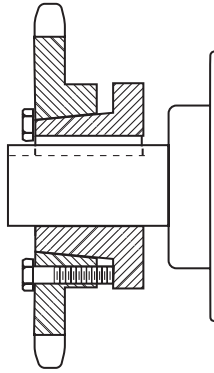

1. Be sure the tapered cone surfaces of the bushing and the inside of the driven product are clean and free of anti-seize lubricants.
2. Slide QD bushing on shaft, flange end first. Assemble key.
3. Position QD bushing on shaft. Tighten set screw over key "hand tight" with standard Allen wrench only. Do not use excessive force.
4. Slide large end of sheave or sprocket taper bore into position over cone aligning drilled bolt holes in sheave or sprocket with tapped holes in flange of bushing. Assemble pull-up bolts and lock washers.

NOTE: Install M thru S bushings in the hub so that the two extra holes in the hub are located as far as possible from the bushing's saw cut.

5. Tighten pull-up bolts alternately and evenly to tightness indicated in torque table on back. Do not use extensions on wrench handles. There should be a gap between the face of the sheave or sprocket hub and the flange of the QD bushing to insure a satisfactory cone grip and press fit.

CAUTION: THIS GAP MUST NOT BE CLOSED.

DISMOUNTING

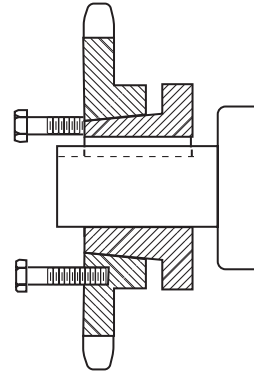

1. Remove pull-up bolts and screw them into TAPPED holes in sheave or sprocket and against flange of QD bushing to break cone grip.
2. Loosen set screw and slide QD bushing from shaft.

WARNING: Because of the possible danger to person(s) or property from accidents which may result from the improper use of products, it is important that correct procedures be followed: Products must be used in accordance with the engineering information specified in the catalog. Proper installation, maintenance and operation procedures must be observed. The instructions given above must be followed. Inspections should be made as necessary to assure safe operation under prevailing conditions. All rotating power transmission products when used in a drive are potentially dangerous and must be guarded by the user as required by applicable laws, regulations, standards, and good safety practice. (Refer to ANSI Standard B15.1.)

REVERSE Mounting Assembly

FOR QD SHEAVES AND SPROCKETS USING JA, SH, SD, SDS, SK, SF, E, F, & J BUSHINGS

These bushings, as well as the sprockets and sheaves for them, are each drilled with six holes (three drilled and three tapped) to allow pull-up bolts to be inserted from either side. This enables variations of mounting characteristics to suit a particular installation.

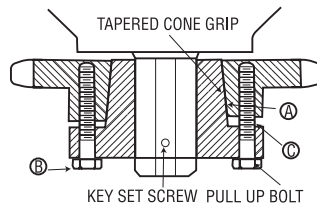
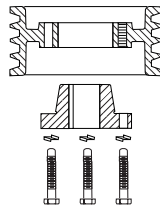
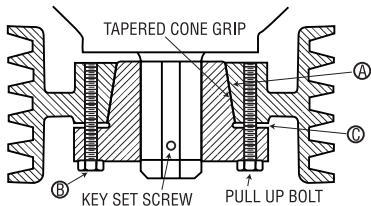

1. Be sure the tapered cone surfaces of the bushing and the inside of the driven product are clean and free of anti-seize lubricants.
2. Assemble sheave or sprocket with bolts inserted (But not tightened) through DRILLED holes in bushing flange into TAPPED holes in sheave, sprocket, or other *Martin* QD part.
3. With key in shaft keyseat, slide assembly into approximate position on shaft with flange end of bushing away from bearing.
4. Position QD bushing on shaft by tightening set screw over key "hand tight" with standard Allen wrench only. Do not use excessive force.
5. Tighten pull-up bolts alternately and evenly to tightness indicated in torque table below. Do not use extensions on wrench handles. There should be a gap between the face of the sheave or sprocket hub and the flange of the QD bushing to insure a satisfactory cone grip and press fit. CAUTION: THIS GAP MUST NOT BE CLOSED.

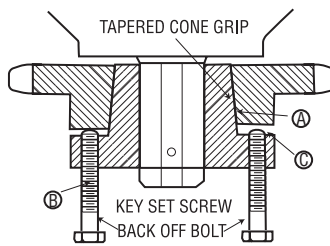
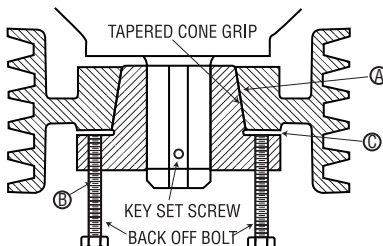

1. Remove pull-up bolts and screw them into TAPPED holes in bushing flange and against hub of sheave or sprocket to break cone grip.
2. Loosen set screw in bushing flange and slide QD bushing from shaft.

B-2

CAUTION

WARNING: USE OF ANTI-SEIZE LUBRICANT ON TAPERED CONE SURFACES OR ON BOLT THREADS WHEN MOUNTING MAY RESULT IN DAMAGE TO SHEAVES AND SPROCKETS. THIS VOIDS ALL MANUFACTURER'S WARRANTIES.

BOLT TORQUE TABLE

QD Bushing Size	Size of Cap Screw	Wrench Torque in. / lbs.
JA	10 - 24	60
SH, SDS, SD	1/4 - 20	108
SK	5/16 - 18	180
SF	3/8 - 16	360
E	1/2 - 13	720
F	9/16 - 12	900
J	5/8 - 11	1620
M	3/4 - 10	2700
N	7/8 - 9	3600
P	1 - 8	5400
W	1-1/8 - 7	7200
S	1-1/4 - 7	9000

★F = Length of Mating Bore

★★G = Gap Between QD Bushing and Mating Hub

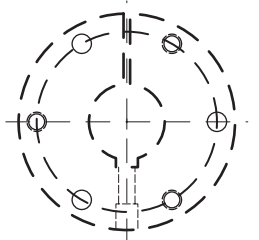

Bushings
"JA" to "J" Inclusive

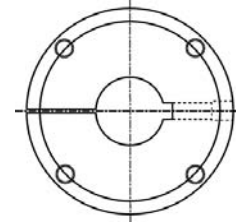
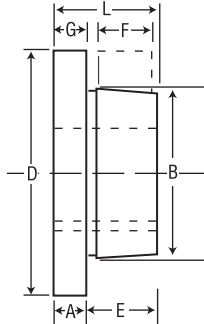

Bushings
"M" to "S" Inclusive

QD Bushings — Steel

Bushing	Dimensions (Inches)								Cap Bolt Circle	Screws Required	Stock Bore Range			Average Weight (Approx.)
	A	B	D	E	F	G	L	Maximum						
								Minimum			Standard Keyway	Shallow Keyway		
SF-STL	5/16	3.125	4 5/8	1 1/2	1 1/4	1/8	2 1/8	3	3 1/2 x 2	1/2	2 5/16	2 1/8	3.0	
E-STL	3/4	3.834	6	1 5/8	1 5/8	1/8	2 3/8	5	3 1/2 x 2 1/2	3/4	2 5/8	3 1/8	10.0	
F-STL	13/16	4.437	6 5/8	2 1/8	2 1/2	3/16	3	5	3 5/8 x 3 3/8	1	3 1/8	4	11.5	
J-STL	1	5.148	7 1/4	3 1/8	3 3/8	3/16	4 1/8	6	3 3/4 x 4 1/4	1 1/8	3 3/8	4 1/8	18.0	
M-STL	1 1/4	6.500	9	5 1/8	5 3/8	3/16	6 1/8	7	4 3/4 x 6 1/4	2	4 1/8	5 1/8	37.0	
N-STL	1 1/2	7.000	10	6 3/8	6 3/4	1/8	8 1/8	8 1/2	4 1/2 x 8 1/2	2 1/2	5 1/8	5 3/8	57.0	

Bushing	Bores	Keyway
SF-STL	2 1/8 - 2 1/8	5/8 x 3/16
	2 1/8 - 2 1/8	5/8 x 1/16
	2 1/8 - 2 1/8	5/8 x 1/32
E-STL	7/8 - 2 1/8	STD.
	2 1/8 - 3 1/4	3/4 x 1/8
	3 1/8 - 3 1/2	7/8 x 1/16
F-STL	1 - 3 1/8	STD.
	3 3/8 - 3 3/8	7/8 x 3/16
	3 3/8 - 3 13/16	1 x 1/8
	4	NONE
J-STL	3 1/8 - 3 3/4	STD.
	3 3/8 - 4 1/2	1 x 1/8
M-STL	2 - 4 3/8	STD.
	4 3/8 - 5 1/2	1 1/4 x 1/4
N-STL	2 1/2 - 5 1/8	STD.
	5 1/8 - 5 1/2	1 1/4 x 1/4
	5 1/8 - 5 1/4	1 1/2 x 1/4

Shallow Key Dimension — Standard			
Key Seat	Key	Keyway	Key
1/4 x 1/32	1/4 x 3/32	3/4 x 1/8	3/4 x 1/8
1/4 x 1/16	1/4 x 3/16	7/8 x 1/16	7/8 x 1/2
3/8 x 1/32	3/8 x 1/32	7/8 x 3/16	7/8 x 5/8
3/8 x 1/16	3/8 x 1/4	1 x 1/8	1 x 5/8
3/8 x 1/8	3/8 x 3/16	1 1/4 x 1/4	1 1/4 x 7/8
1/2 x 1/32	1/2 x 1/32	1 1/2 x 1/8	1 1/2 x 7/8
1/2 x 1/16	1/2 x 3/16	1 1/2 x 1/4	1 1/2 x 1
1/2 x 1/8	1/2 x 3/8	1 3/4 x 1/8	1 3/4 x 3/4
5/8 x 1/16	5/8 x 3/8	1 3/4 x 1/4	1 3/4 x 7/8
3/4 x 1/16	3/4 x 1/16	2 x 1/4	2 x 1

Standard Keyway and Key Dimension		
Bores	Keyway	Key
7/8	3/8 x 3/32	3/8 x 3/16
1 1/8 - 1 1/4	1/4 x 1/8	1/4 x 1/4
1 1/8 - 1 3/8	5/8 x 3/32	5/8 x 3/16
1 1/8 - 1 3/4	3/8 x 3/16	3/8 x 3/8
1 13/16 - 2 1/4	1/2 x 1/4	1/2 x 1/2
2 1/8 - 2 1/4	5/8 x 3/16	5/8 x 5/8
2 13/16 - 3 1/4	3/4 x 3/8	3/4 x 3/4
3 1/8 - 3 3/4	7/8 x 1/16	7/8 x 7/8
3 3/8 - 4 1/2	1 x 1/2	1 x 1
4 3/8 - 5 1/2	1 1/4 x 3/8	1 1/4 x 1 1/4
5 1/8 - 6 1/2	1 1/2 x 3/4	1 1/2 x 1 1/2
6 1/8 - 7 1/2	1 3/4 x 3/4	1 3/4 x 1 1/2
7 1/8 - 9	2 x 3/4	2 1/2 x 1 1/2
9 1/8 - 11	2 1/2 x 7/8	--
11 1/8 - 13	3 x 1	--

Shallow Key Dimension — Steel			
Key Seat	Key	Keyway	Key
1/4 x 1/32	1/4 x 5/32	3/4 x 1/16	3/4 x 7/16
1/4 x 1/16	1/4 x 3/16	3/4 x 1/8	3/4 x 1/2
3/8 x 1/32	3/8 x 1/32	7/8 x 1/16	7/8 x 1/2
3/8 x 1/16	3/8 x 1/4	7/8 x 3/16	7/8 x 5/8
3/8 x 1/8	3/8 x 3/16	1 x 1/8	1 x 5/8
1/2 x 1/32	1/2 x 1/32	1 1/4 x 1/4	1 1/4 x 7/8
1/2 x 1/16	1/2 x 3/16	1 1/2 x 1/4	1 1/2 x 1
1/2 x 1/8	1/2 x 3/8	1 3/4 x 1/4	1 3/4 x 3/4
5/8 x 1/16	5/8 x 3/8	1 3/4 x 3/8	1 3/4 x 1
5/8 x 3/16	5/8 x 1/2	2 x 1/4	2 x 1

Bushing	Plain Bores Not Split
SH-STL	1/2
SD-STL	1/2
SK-STL	1/2
SF-STL	1 1/8
E-STL	7/8 - 1 1/8
F-STL	1 - 2 1/8 - 2 13/16
J-STL	1 1/8 - 2 13/16
M-STL	2 - 2 1/8
N-STL	2 1/8 - 4 13/16

Reborable QD bushings made of Stainless Steel are available in many sizes. Non stock sizes are available on MTO basis.

Standard QD Bushings



BUSHINGS

Bushing	Dimensions (Inches)								Cap Screws Required	Stock Bore Range			Set Screw Size	Average Weight (Approx.)
	A	B	D	E	F	G	L	Bolt Circle		Maximum				
										Minimum	Standard Keyway	Shallow Keyway		
JA	3/8	1.375	2	1/16	3/16	1/8	1 1/16	1.665	3-10 x 1	3/8	1	1 1/4	10-24	.9
SH	7/16	1.871	2 1/16	3/8	13/16	1/2	1 5/16	2 1/4	3-1/4 x 1 1/2	1/2	1 1/8	1 1/2	1/4	1
SDS	1/2	2.187	3 3/16	7/8	3/4	1/2	1 1/2	2 1/16	3-1/4 x 1 1/2	1/2	1 1/16	2	1/4	1
SD	1/2	2.187	3 3/16	1 1/16	1 1/4	1/2	1 13/16	2 1/16	3-1/4 x 1 1/2	1/2	1 1/16	1 1/16	1/4	1.5
SK	3/8	2.812	3 3/8	1 1/8	1 1/4	1/2	1 5/8	3 3/16	3-5/8 x 2	1/2	2 1/8	2 1/2	5/16	2
SF	3/8	3.125	4 1/8	1 1/2	1 1/4	1/2	2 1/16	3 1/8	3-3/8 x 2	1/2	2 3/16	2 3/16	5/16	3
E	3/4	3.834	6	1 1/8	1 1/8	1/2	2 1/2	5	3-1/2 x 2 1/2	3/4	2 3/8	3 1/2	3/4	10
F	13/16	4.437	6 3/8	2 13/16	2 1/2	3/8	3 3/8	5 1/2	3-3/8 x 3 3/8	1	3 3/16	3 3/16	1/2	11.5
J	1	5.148	7 1/4	3 1/2	3 3/16	3/8	4 1/2	6 1/4	3-3/4 x 4 1/2	1 1/16	3 3/4	4 1/2	3/4	18
M	1 1/4	6.500	9	5 1/2	5 3/16	3/8	6 3/4	7 3/4	4-3/4 x 6 3/4	1 1/16	4 3/4	5 1/2	3/4	37
N	1 1/2	7.000	10 1/4	6 3/8	6 1/4	1/4	8 1/8	8 3/8	4-1/2 x 8 1/2	2 1/16	5 1/8	6	3/4	57
P	1 3/4	8.250	11 3/4	7 3/8	7 1/4	1/4	9 1/8	10	4-1 x 9 1/2	2 3/16	5 3/16	7	3/4	120
W	2	10.437	15	9 3/8	9	1/4	11 1/8	12 3/4	4-1 1/4 x 11 1/2	4	7 1/2	8 1/2	1	250
S	3 1/4	12.125	17 3/4	12 1/2	12	3/8	15 1/2	15	5-1 1/4 x 15 1/2	6	8 1/4	10	1 1/4	400

Inch Bore

Bushing	Bores	Keyway
JA	3/8 - 7/16 1/2 - 1 1 1/8 - 1 1/2 1 3/8 1 1/4	NO K.W. STD. 1/4 x 1/8 1/4 x 1/8 NO K.W.
SH	1/2 - 1 1/8 1 1/16 - 1 1/2 1 1/8 - 1 1/2 1 1/16	STD 3/8 x 1/16 3/8 x 1/16 NO K.W.
SDS	1/2 - 1 13/16 1 1/4 1 13/16 1 13/16 2	STD. 3/8 x 3/8 1/2 x 1/2 1/2 x 1/2 NO K.W.
SD	1/2 - 1 13/16 1 1/4 1 13/16 1 1/8 1 13/16 2	STD. 3/8 x 3/8 1/2 x 1/2 1/2 x 1/8 1/2 x 1/8 NO K.W.
SK	1/2 - 2 1/2 2 3/16 - 2 1/4 2 3/8 - 2 1/2 2 3/8 - 2 3/8	STD. 1/2 x 1/2 3/8 x 1/8 NO K.W.
SF	1/2 - 2 1/4 2 3/8 - 2 1/2 2 3/8 - 2 1/4 2 3/8 - 2 1/2 2 3/8	STD. 3/8 x 3/8 3/8 x 1/8 3/8 x 1/8 3/8 x 1/2
E	3/4 - 2 1/2 2 3/8 - 3 1/4 3 3/8 - 3 1/2 3 3/8	STD. 3/4 x 3/8 3/8 x 1/8 3/8 x 1/8
F	1 - 3 3/8 3 3/8 - 3 3/4 3 3/8 - 3 13/16 4	STD. 3/8 x 3/8 1 x 1/4 NONE
J	1 1/4 - 3 3/4 3 13/16 - 4 1/2	STD. 1 x 1/8
M	2 - 4 1/4 4 13/16 - 5 1/2	STD. 1 1/4 x 1/4
N	2 1/8 - 5 5 1/8 - 5 1/2 5 3/8 - 6	STD. 1 1/4 x 1/4 1 1/2 x 1/4
P	2 3/8 - 5 13/16 6 - 6 1/2 6 3/8 - 7	STD. 1 1/2 x 1/4 1 3/4 x 1/8
W	4 - 7 1/2 7 3/8 - 8 1/2	STD. 2 x 1/4

Millimeter Bore

Bushing	Bore MM	Key* WXT
SH	24, 25 28, 30 32, 35	8x7 10x8
SDS	24, 25 28, 30 32, 35 38 40, 42	8x7 10x8 12x8
SD	24, 25 28, 30 32, 35 38 40, 42	8x7 10x8 12x8
SK	24, 25 28, 30 32, 35 38 40, 42 48, 50 55	8x7 10x8 12x8 14x9 16x10
SF	28, 30 32, 35 38 40, 42 48, 50 55 60	8x7 10x8 12x8 14x9 16x10 18x11
E	35, 38 40, 42 48, 50 55 60, 65 70, 75	10x8 12x8 14x9 16x10 18x11 20x12
F	48, 50 55 60, 65 70, 75 80, 85 90	14x9 16x10 18x11 20x12 22x14 25x14
J	50 55 60, 65 70, 75 80, 85 90, 95 100	14x9 16x10 18x11 20x12 22x14 25x14 28x16

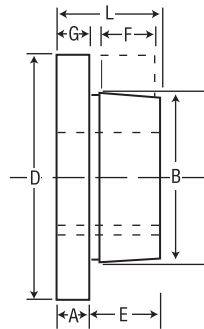

★Important — The metric system does not refer to keyseat or keyway dimensions as does the English system; instead dimensions are given for the key itself which is rectangular in shape, not square as in the English system.

NOTE: .03937" = 1mm
Ex — 24 mm = 0.94488"

TO ORDER:
SH 24 mm

Keystock provided for nonstandard keyways.

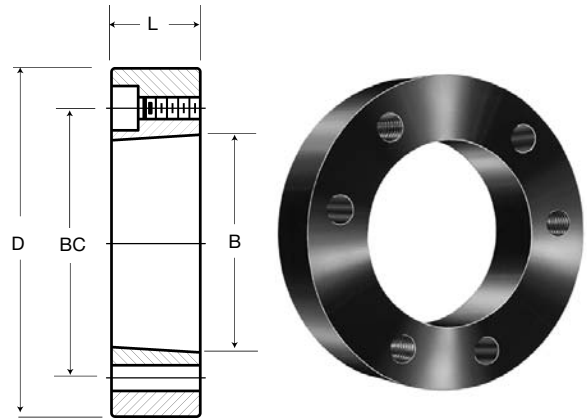
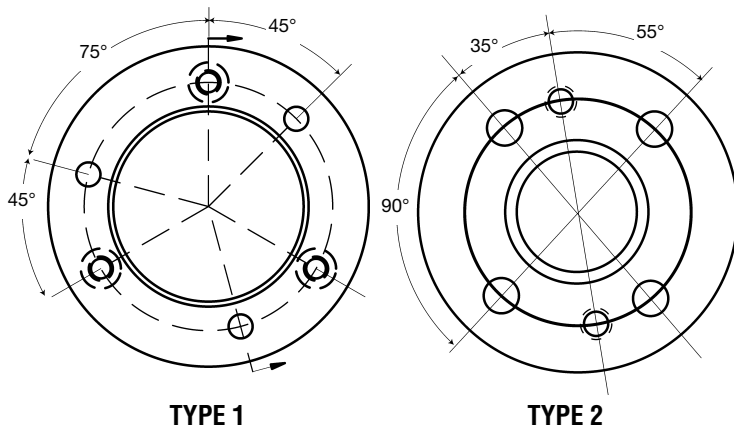

Martin QD weld-on hubs are suitable for use in many applications, such as welding to plate steel sprockets.

Weld-on hubs are made of steel, drilled tapped and taper bored for QD bushings

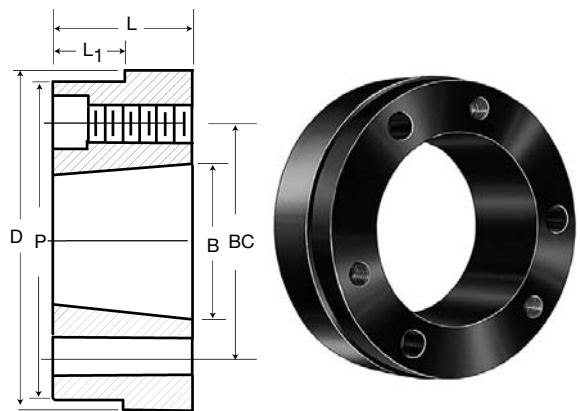

WELD-ON HUB TYPE QD

QD Weld-On Hubs

Catalog Number	Dimensions — Inches						Type Drilling	Weight Pounds	Mounting
	D★	L	B	P	L ₁	BC			
JA-A	2.250	5/16	1.375	2.125	3/16	1 1/2	1	.4	STD or Reverse Mount ↓
SH-A	3.000	5/16	1.871	—	—	2 1/4	1	1	
SDS-A	3.500	3/4	2.188	—	—	2 1/16	1	1 1/4	
SK-A	4.375	1 1/4	2.813	—	—	3 3/16	1	3	
SF-A	5.000	1 1/4	3.125	—	—	3 3/8	1	4	STD Mount Only
E-A	6.250	1 1/8	3.832	—	—	5	1	9	
F-A	7.000	2 1/2	4.437	—	—	5 5/8	1	16	
J-A	7.750	3 3/16	5.140	—	—	6 1/4	1	22.5	
M-A	9.500	5 5/16	6.494	9.250	3 3/16	7 1/8	2	50	
N-A	10.500	6 1/4	6.990	10.250	4 1/2	8 1/2	2	75	
P-A	13.000	7 1/4	8.240	—	—	10	2	155	
W-A	15.500	9	10.437	—	—	12 3/4	2	300	
S-A	19.500	12	12.125	18.75	7.5	15	2	558	

★Tolerance of D Dimension
JA-A Thru J-A = (+.000-.002)
M-A Thru S-A = (+.000-.003)

QD Short Bushings

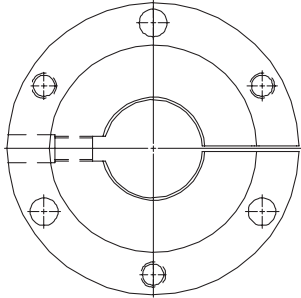

Bushings:
JS

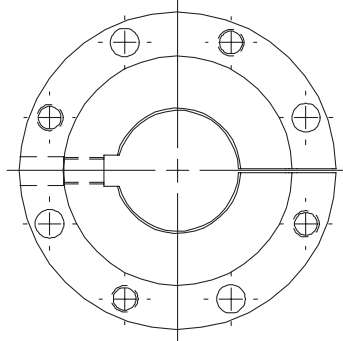

Bushings:
MS TO WS inclusive

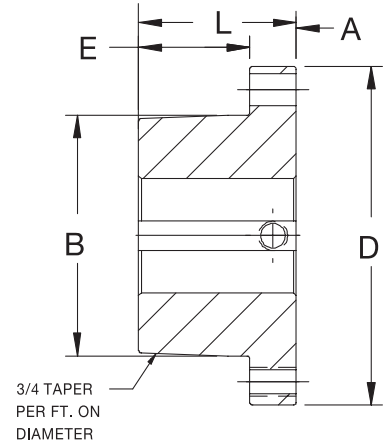

Inch Bore

Bushing	Bores	Keyway	Weight	
JS	2 ⁷ / ₁₆	5/8 x 5/16	19	
	2 ¹⁵ / ₁₆	3/4 x 3/8	17	
	3 ¹ / ₁₆	7/8 x 7/16	15	
	3 ¹ / ₂		15	
	3 ¹⁵ / ₁₆	1 x 1/2	13	
4 ¹ / ₁₆		10		
MS	3 ⁷ / ₁₆	7/8 x 7/16	38	
	3 ¹ / ₂		37	
	3 ¹⁵ / ₁₆	1 x 1/2	34	
	4 ¹ / ₁₆		30	
	4 ¹⁵ / ₁₆		26	
5 ¹ / ₁₆	1 1/4 x 1/4	21		
5 ¹ / ₂		20		
NS	3 ¹⁵ / ₁₆	1 x 1/2	54	
	4 ¹ / ₁₆		49	
	4 ¹⁵ / ₁₆	1 1/4 x 5/8	43	
	5 ¹ / ₁₆		38	
	5 ¹ / ₂		37	
5 ¹⁵ / ₁₆	1 1/2 x 1/4	31		
6		30		
PS	4 ¹ / ₁₆	1 1/4 x 5/8	76	
	5 ¹ / ₁₆		70	
	5 ¹⁵ / ₁₆	1 1/2 x 3/4	62	
	6		62	
	6 ¹ / ₁₆		1 1/2 x 1/4	55
	6 ¹ / ₂			54
6 ¹⁵ / ₁₆	1 3/4 x 1/8	47		
7		45		
WS	5 ¹ / ₁₆	1 1/4 x 5/8	154	
	5 ¹⁵ / ₁₆		145	
	6		144	
	6 ¹ / ₁₆	1 1/2 x 3/4	136	
	6 ¹ / ₂		135	
	6 ¹⁵ / ₁₆		126	
	7	1 3/4 x 3/4	125	
	7 ¹ / ₂		114	
	7 ¹⁵ / ₁₆		106	
8	2 x 1/4	105		
8 ¹ / ₁₆		94		
8 ¹ / ₂		93		



Martin QD Short Bushings are suitable for use in belt conveyor applications wherever the short hubs of a conveyor pulley require the QD Short Bushing style.

Dimensions

Bushing	Dimensions (Inches)					Bolt Circle	Cap Screws Required	Set Screw Size
	A	B	D	E	L			
JS	1.00	5.1484	7.25	2.38	3.38	6.25	5/8 x 2 1/2 (3)	5/8
MS	1.19	6.5000	9.00	3.62	4.81	7.88	3/4 x 3 (4)	3/4
NS	1.50	7.0000	10.00	4.50	6.00	8.50	7/8 x 3 1/2 (4)	7/8
PS	1.50	8.2500	11.75	5.00	6.50	10.00	1 x 4 (4)	7/8
WS	1.75	10.4370	15.00	5.50	7.25	12.75	1 1/2 x 5 (4)	1

All dimensions are in inches, weight in pounds.

IMPORTANT NOTE: Please follow the instructions on this sheet in order for the *Martin* bushing to perform satisfactorily.

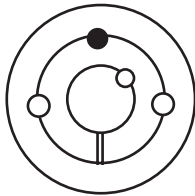

1008 to 3030

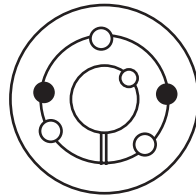

3535 to 6050

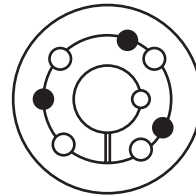

7060 to 1085

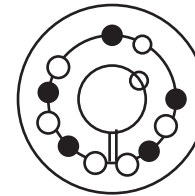

102100

INSTALLATION

1. Clean all oil, dirt, and paint from shaft, bushing bore, outside of bushing and component (sprocket, sheave...etc.) bore.
2. Insert bushing into component. Match the hole pattern, not the threaded holes (each hole will be threaded on one side only.)
3. Thread set or cap screws into those half threaded holes indicated by ○ on above diagram. Mount assembly on shaft.
4. Alternately torque set or cap screws* to recommended torque setting in chart below.
5. On 3535 and larger bushings use a block, sleeve or drift and hammer large end of bushing (do not hammer bushing directly).
6. Repeat steps 4 and 5 until torque wrench reading, after hammering, is the same as before hammering.
7. Fill all unoccupied holes with grease.

REMOVAL

1. Remove all set or cap screws.
2. Insert set or cap screws in holes indicated by ● on drawing. Loosen bushing by alternately tightening set or cap screws.
3. To reinstall, complete all seven (7) installation instructions.

RECOMMENDED TORQUE TABLE

Bushing No.	Set or Cap Screw	Wrench Torque in. / lbs.
1008, 1108	1/4 - 20 Socket Set Screw	55
1210, 1215, 1310	3/8 - 16 Socket Set Screw	175
1610, 1615	3/8 - 16 Socket Set Screw	175
2012	7/16 - 14 Socket Set Screw	280
2517, 2525	1/2 - 13 Socket Set Screw	430
3020, 3030	5/8 - 11 Socket Set Screw	800
3535	1/2 - 13 Socket Head Cap Screw	1,000
4040	5/8 - 11 Socket Head Cap Screw	1,700
4545	3/4 - 10 Socket Head Cap Screw	2,450
5050	7/8 - 9 Socket Head Cap Screw	3,100
6050, 7060, 8065	1-1/4 - 7 Socket Head Cap Screw	7,820
10085, 120100	1 - 1/2 - 6 Socket Head Cap Screw	13,700

* If two bushings are used on same component and shaft, fully tighten one bushing before working on the other.

CAUTION

WARNING: USE OF ANTI-SEIZE LUBRICANT ON TAPERED CONE SURFACES OR ON BOLT THREADS WHEN MOUNTING MAY RESULT IN DAMAGE TO SHEAVES AND SPROCKETS. THIS VOIDS ALL MANUFACTURER'S WARRANTIES.

WARNING: Because of the possible danger to person(s) or property from accidents which may result from the improper use of products, it is important that correct procedures be followed: Products must be used in accordance with the engineering information specified in the catalog. Proper installation, maintenance and operation procedures must be observed. The instructions given above must be followed. Inspections should be made as necessary to assure safe operation under prevailing conditions. All rotating power transmission products when used in a drive are potentially dangerous and must be guarded by the user as required by applicable laws, regulations, standards, and good safety practice. (Refer to ANSI Standard B15.1.)

Taper Bushings Dimensions

BUSHINGS

No. 1008 to 3030 Taper Bushings

Bushing Number	Bore	Wt.	Bushing Keyseat	Shaft Keyseat
1008	1/2 to 9/16	.27	1/8 x 1/16	1/8 x 1/16
	5/16 to 1/2	.21	3/16 x 3/32	3/16 x 3/32
	15/16 to 1	.16	1/4 x 1/8 Δ	1/4 x 1/8
1108	1/2 to 9/16	.33	1/8 x 1/16	1/8 x 1/16
	5/16 to 1/2	.27	3/16 x 3/32	3/16 x 3/32
	15/16 to 1	.22	1/4 x 1/8	1/4 x 1/8
1210	1/2 to 9/16	.61	1/8 x 1/16	1/8 x 1/16
	5/16 to 1/2	.55	3/16 x 3/32	3/16 x 3/32
	15/16 to 1 1/4	.49	1/4 x 1/8	1/4 x 1/8
1215	1/2 to 9/16	.8	1/8 x 1/16	1/8 x 1/16
	5/16 to 1/2	.7	3/16 x 3/32	3/16 x 3/32
	15/16 to 1 1/4	.6	1/4 x 1/8	1/4 x 1/8
1310	1/2 to 9/16	.7	1/8 x 1/16	1/8 x 1/16
	5/16 to 1/2	.6	3/16 x 3/32	3/16 x 3/32
	15/16 to 1 1/4	.6	1/4 x 1/8	1/4 x 1/8
1610	1/2 to 9/16	.9	1/8 x 1/16	1/8 x 1/16
	5/16 to 1/2	.8	3/16 x 3/32	3/16 x 3/32
	15/16 to 1 1/4	.7	1/4 x 1/8	1/4 x 1/8
1615	1 1/16 to 1 1/2	.7	3/16 x 3/32	3/16 x 3/32
	1 1/8 to 1 1/4	.6	3/8 x 3/16	3/8 x 3/16
	1 1/16 to 1 1/8	.5	3/8 x 1/8 Δ	3/8 x 3/16
2012	1/2 to 9/16	1.2	1/8 x 1/16	1/8 x 1/16
	5/16 to 1/2	1.1	3/16 x 3/32	3/16 x 3/32
	15/16 to 1	1.0	1/4 x 1/8	1/4 x 1/8
2517	1 1/16 to 1 1/2	.8	3/16 x 3/32	3/16 x 3/32
	1 1/8 to 1 1/4	.7	3/8 x 3/16	3/8 x 3/16
	1 1/16 to 1 1/8	.6	3/8 x 1/8 Δ	3/8 x 3/16
3020	1/2 to 9/16	1.7	1/8 x 1/16	1/8 x 1/16
	5/16 to 1/2	1.6	3/16 x 3/32	3/16 x 3/32
	15/16 to 1	1.5	1/4 x 1/8 Δ	1/4 x 1/8
3030	1 1/16 to 1 1/2	1.4	5/16 x 3/32	5/16 x 3/32
	1 1/8 to 1 1/4	1.2	3/8 x 3/16	3/8 x 3/16
	1 1/16 to 1 1/8	1.0	1/2 x 1/4	1/2 x 1/4
2525	1 1/16 to 1 1/8	1.0	1/2 x 3/16 Δ	1/2 x 1/4
	1 1/8 to 1 1/4	1.0	1/2 x 1/4	1/2 x 1/4
	1 1/16 to 1 1/8	1.0	1/2 x 3/16 Δ	1/2 x 1/4
2525	1 1/16 to 1 1/8	4.9	3/16 x 3/32	3/16 x 3/32
	1 1/8 to 1 1/4	4.7	1/4 x 1/8	1/4 x 1/8
	1 1/16 to 1 1/8	4.5	5/16 x 3/32	5/16 x 3/32
3020	1 1/16 to 1 1/8	4.2	3/8 x 3/16	3/8 x 3/16
	1 1/8 to 1 1/4	3.3	1/2 x 1/4	1/2 x 1/4
	1 1/16 to 1 1/8	2.5	5/8 x 3/16 Δ	5/8 x 3/16
3020	1 1/16 to 1 1/4	6.5	1/4 x 1/8	1/4 x 1/8
	1 1/8 to 1 1/2	6.3	5/16 x 3/32	5/16 x 3/32
	1 1/16 to 1 1/8	6.0	3/8 x 3/16	3/8 x 3/16
3030	1 1/16 to 1 1/8	5.3	1/2 x 1/4	1/2 x 1/4
	1 1/8 to 1 1/4	4.5	5/8 x 3/16	5/8 x 3/16
	1 1/16 to 1 1/8	3.9	3/4 x 1/8 Δ	3/4 x 3/8
3030	1 1/16 to 1 1/4	9.2	1/4 x 1/8	1/4 x 1/8
	1 1/8 to 1 1/2	8.9	5/16 x 3/32	5/16 x 3/32
	1 1/16 to 1 1/8	8.6	3/8 x 3/16	3/8 x 3/16
3030	1 1/8 to 1 1/4	7.6	1/2 x 1/4	1/2 x 1/4
	1 1/16 to 1 1/8	6.2	5/8 x 3/16	5/8 x 3/16
	1 1/16 to 1 1/8	5.0	3/4 x 1/8 Δ	3/4 x 3/8

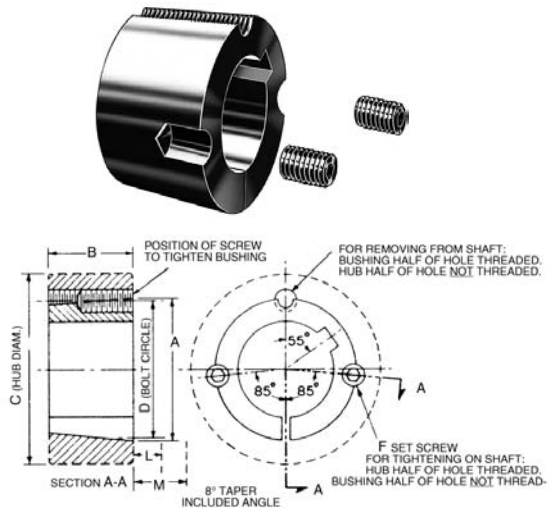

Dimensions

Bushing Number	A	B	CØ			D	F†	L★		M★★	
			Class 20 Gray Iron	Class 30 Gray Iron	Steel			Standard Hex. Key	Short Key‡	Standard Hex. Key	Short Key‡
1008	1.386	3/8	2 3/8	2 3/8	1 15/16	1 21/64	1/4 x 1/2	1	5/8	1 1/4	3/4
1108	1.511	3/8	2 1/2	2 3/8	2 1/8	1 7/64	1/4 x 1/2	1	5/8	1 1/4	3/4
1210	1 1/8	1	3	3 1/4	2 3/8	1 1/4	3/8 x 3/8	1	1 3/16	1 1/2	1 1/8
1215	1 1/8	1 1/2	3	2 1/2	2 3/8	1 1/4	3/8 x 3/8	1	1 3/16	1 1/2	1 1/8
1310	2	1	3 3/4	3 3/8	3	1 1/8	3/8 x 3/8	1	1 3/16	1 1/2	1 1/8
1610	2 1/4	1	4	3 3/4	3 3/4	2 1/8	3/8 x 3/8	1	1 3/16	1 1/2	1 1/8
1615	2 1/4	1 1/2	3 3/4	3 3/8	3	2 1/8	3/8 x 3/8	1	1 3/16	1 1/2	1 1/8
2012	2 3/4	1 1/4	4 3/4	4 3/8	3 3/8	2 3/8	7/16 x 7/8	1 1/8	1 5/16	2	1 3/8
2517	3	1 3/4	5 1/2	4 3/4	4 3/4	3 3/4	1/2 x 1	1	1	2 1/4	1 3/8
2525	3	2 1/2	4 3/4	4 1/2	4 1/4	3 3/4	1/2 x 1	1	1	2 1/4	1 3/8
3020	4 1/4	2	7	6 1/4	5 3/4	4	3/4 x 1 1/4	1 1/8	1 3/16	2 1/8	2 1/16
3030	4 1/4	3	6 1/4	5 3/4	5 3/4	4	3/4 x 1 1/4	1 1/8	1 3/16	2 1/8	2 1/16

Bushings cannot be bored larger than largest bore listed.

For detail dimensions required for machining hubs, consult factory.

Δ Key furnished for these sizes only.

Ø For general reference. Severe conditions may require larger hub. Heavy well-located web may permit smaller hub. Hub diameter required depends on the particular application. Consult *Martin* giving full information on the proposed design. Hub diameters shown are based on 20,000, 30,000, and 50,000 P.S.I. minimum ultimate tensile strength respectively for Class 20 gray iron, Class 30 gray iron, and steel hubs.

† 2 screws required. Use in positions shown for tightening bushing on shaft. In removing bushing from shaft, remove screws and use one of them in the other hole. Bushing price includes screws.

★ Space required to tighten bushing. Also space required to loosen screws to permit removal of hub by puller.

★★ Space required to loosen bushing using one screw as jackscrew — no puller required.

‡ Standard hex key cut to minimum usable length.

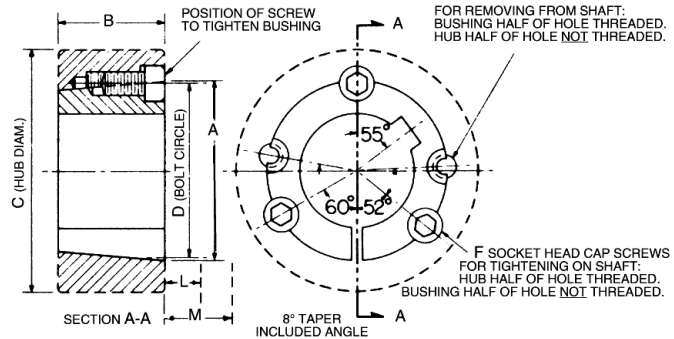

No. 3535 to 5050 Bushings

Bushing Number	Bore	Weight	Bushing Keyseat	Shaft Keyseat	A	B	C ϕ			D	F†	G	R
							Class 20 Gray Iron	Class 30 Gray Iron	Steel				
3535	1 $\frac{3}{16}$ to 1 $\frac{1}{4}$	14	$\frac{1}{4} \times \frac{1}{8}$	$\frac{1}{4} \times \frac{1}{8}$	5	3 $\frac{1}{2}$	7 $\frac{3}{4}$	7	6 $\frac{1}{2}$	4.83	$\frac{1}{2} \times 1\frac{1}{2}$	39°	▲
	1 $\frac{1}{8}$ to 1 $\frac{3}{8}$	14	$\frac{5}{16} \times \frac{5}{32}$	$\frac{5}{16} \times \frac{5}{32}$									
	1 $\frac{1}{16}$ to 1 $\frac{1}{8}$	13	$\frac{3}{8} \times \frac{3}{16}$	$\frac{3}{8} \times \frac{3}{16}$									
	1 $\frac{1}{16}$ to 2 $\frac{1}{4}$	12	$\frac{1}{2} \times \frac{1}{4}$	$\frac{1}{2} \times \frac{1}{4}$									
	2 $\frac{1}{16}$ to 2 $\frac{1}{2}$	11	$\frac{5}{8} \times \frac{3}{16}$	$\frac{5}{8} \times \frac{3}{16}$									
	2 $\frac{1}{16}$ to 3 $\frac{1}{4}$	9	$\frac{3}{4} \times \frac{3}{8}$	$\frac{3}{4} \times \frac{3}{8}$									
4040	3 $\frac{1}{16}$ to 3 $\frac{1}{2}$	8	$\Delta \frac{1}{4} \times \frac{1}{4}$	$\frac{7}{8} \times \frac{7}{16}$	5 $\frac{1}{2}$	4	9 $\frac{1}{2}$	8 $\frac{1}{2}$	7 $\frac{1}{2}$	5.54	$\frac{5}{8} \times 1\frac{1}{4}$	40°	▲
	1 $\frac{1}{16}$ to 1 $\frac{1}{4}$	22	$\frac{3}{8} \times \frac{3}{16}$	$\frac{3}{8} \times \frac{3}{16}$									
	1 $\frac{1}{8}$ to 2 $\frac{1}{4}$	21	$\frac{1}{2} \times \frac{1}{4}$	$\frac{1}{2} \times \frac{1}{4}$									
	2 $\frac{1}{16}$ to 2 $\frac{1}{2}$	19	$\frac{5}{8} \times \frac{3}{16}$	$\frac{5}{8} \times \frac{3}{16}$									
	2 $\frac{1}{16}$ to 3 $\frac{1}{4}$	17	$\frac{3}{4} \times \frac{3}{8}$	$\frac{3}{4} \times \frac{3}{8}$									
	3 $\frac{1}{16}$ to 3 $\frac{3}{8}$	15	$\frac{7}{8} \times \frac{7}{16}$	$\frac{7}{8} \times \frac{7}{16}$									
4545	3 $\frac{1}{16}$ to 3 $\frac{3}{8}$	14	$\frac{1}{8} \times \frac{1}{16}$	$\frac{7}{8} \times \frac{7}{16}$	6 $\frac{1}{2}$	4 $\frac{1}{2}$	10 $\frac{1}{2}$	9 $\frac{1}{2}$	8 $\frac{3}{4}$	6.13	$\frac{3}{4} \times 2$	40°	▲
	3 $\frac{1}{16}$ to 4	13	$\Delta 1 \times \frac{1}{4}$	$1 \times \frac{1}{2}$									
	1 $\frac{1}{16}$ to 2 $\frac{1}{4}$	30	$\frac{1}{2} \times \frac{1}{4}$	$\frac{1}{2} \times \frac{1}{4}$									
	2 $\frac{1}{16}$ to 2 $\frac{1}{2}$	28	$\frac{5}{8} \times \frac{3}{16}$	$\frac{5}{8} \times \frac{3}{16}$									
	2 $\frac{1}{16}$ to 3 $\frac{1}{4}$	26	$\frac{3}{4} \times \frac{3}{8}$	$\frac{3}{4} \times \frac{3}{8}$									
	3 $\frac{1}{16}$ to 3 $\frac{3}{8}$	23	$\frac{7}{8} \times \frac{7}{16}$	$\frac{7}{8} \times \frac{7}{16}$									
5050	3 $\frac{3}{16}$ to 4 $\frac{1}{2}$	20	$1 \times \frac{1}{2}$	$1 \times \frac{1}{2}$	7	5	11 $\frac{1}{2}$	10 $\frac{1}{2}$	9 $\frac{1}{2}$	6.72	$\frac{7}{8} \times 2\frac{1}{4}$	37°	▲
	4 $\frac{1}{16}$ to 4 $\frac{1}{2}$	18	$\Delta 1 \times \frac{1}{4}$	$1 \times \frac{1}{2}$									
	2 $\frac{1}{16}$ to 2 $\frac{1}{2}$	38	$\frac{5}{8} \times \frac{3}{16}$	$\frac{5}{8} \times \frac{3}{16}$									
	2 $\frac{1}{16}$ to 3 $\frac{1}{4}$	35	$\frac{3}{4} \times \frac{3}{8}$	$\frac{3}{4} \times \frac{3}{8}$									
	3 $\frac{1}{16}$ to 3 $\frac{3}{8}$	32	$\frac{7}{8} \times \frac{7}{16}$	$\frac{7}{8} \times \frac{7}{16}$									

Bushings cannot be bored larger than largest bore listed.

For detail dimensions required for machining hubs, consult factory.

▲ Key furnished for these sizes only.

Ø For general reference. Severe conditions may require larger hub. Heavy well-located web may permit smaller hub. Hub diameter required depends on the particular application. Consult factory giving full information on the proposed design. Hub diameters shown are based on 20,000, 30,000, and 50,000 P.S.I. minimum ultimate tensile strength respectively for Class 20 gray iron, Class 30 gray iron, and steel hubs.

† 3 screws required. Use in positions shown for tightening bushing on shaft. In removing bushing from shaft, remove screws and use two of them in the other two holes. Bushing price includes screws. See following footnote.

▲ Provide sufficient space to tighten and loosen bushing. Width across flats of screw head is same as screw diameter which is shown in column F.

Martin Taper Bushed Type S Weld-On Hubs are suitable for use in many applications such as for welding to plate steel sprockets. The outside diameters of these hubs have been reduced to a minimum. This is permissible because of the reinforcing strength of the items to which they are to be welded. Cases where the attached item is of small dimensions should be referred to *Martin*.

Type S Weld-On Hubs are made of steel, drilled, tapped, and taper bored for Tapered Bushings. Their small size and the convenience and advantages of Taper Bushed construction make them of great value on many devices for use on shafts.

Taper Bushed Type S Weld-On Hubs

Hub Number	For Use with Bushing Number	Max. Bore of Bushing	Weight	A	B Φ	C★★	D Δ	G	J
S16-4	1610	1%	.9	3	1	.275	.725	2 $\frac{1}{2}$ †	2 $\frac{1}{4}$
S16-6	1610	1%	.9	3	1	.450	.550	2 $\frac{1}{2}$ †	2 $\frac{1}{4}$
S20-6	2012	2	1.8	3 $\frac{5}{16}$	1 $\frac{1}{4}$.450	.800	3 $\frac{1}{2}$ †	2 $\frac{1}{4}$
S20-8	2012	2	1.4	3 $\frac{5}{16}$	1 $\frac{1}{4}$.570	.680	3 $\frac{1}{2}$ †	2 $\frac{1}{4}$
S25-6	2517	2 $\frac{1}{2}$	2.6	4 $\frac{1}{4}$	1 $\frac{1}{2}$.450	1.300	4 $\frac{1}{2}$ †	3 $\frac{3}{8}$
S25-8	2517	2 $\frac{1}{2}$	2.6	4 $\frac{1}{4}$	1 $\frac{1}{2}$.565	1.185	4 $\frac{1}{2}$ †	3 $\frac{3}{8}$
S25-10	2517	2 $\frac{1}{2}$	2.5	4 $\frac{1}{4}$	1 $\frac{1}{2}$.685	1.065	4 $\frac{1}{2}$ †	3 $\frac{3}{8}$
S25-16	2517	2 $\frac{1}{2}$	2.4	4 $\frac{1}{4}$	1 $\frac{1}{2}$	1.090	.660	4 $\frac{1}{2}$ †	3 $\frac{3}{8}$
S30-10	3020	3	4.3	5 $\frac{1}{4}$	2	.675	1.325	5 $\frac{1}{2}$ †	4 $\frac{1}{4}$
S30-16	3020	3	4.2	5 $\frac{1}{4}$	2	1.090	.910	5 $\frac{1}{2}$ †	4 $\frac{1}{4}$
S35	3535	3 $\frac{1}{2}$	12.8	6 $\frac{1}{2}$	3 $\frac{1}{2}$	1.160	2.340	6 $\frac{1}{2}$ \emptyset	5

See dimension tables on preceding page for bushing data and wrench space required.

- † + .000-.002
- Φ + .005-.010
- \emptyset + .001-.003
- Δ + .000-.005
- ★★ + .010-.010

Type S

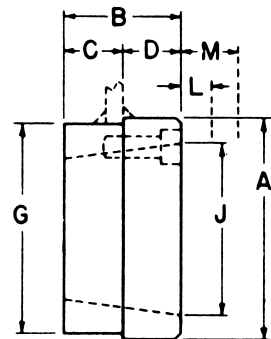

Type W Weld-On Hubs are made of steel, drilled, tapped, and taper bored to receive Tapered Bushings. They are very useful for welding into fan rotors, pulleys, plate sprockets, impellers, agitators, and many other devices which must be firmly fastened to the shaft.

Taper Bushed Type WA Weld-On Hubs

Hub Number	For Use with Bushing Number	Max. Bore of Bushing	Weight	A	B	C	D	F	G	H	J	K
WA12	1215	1 $\frac{1}{4}$	1.3	2 $\frac{1}{2}$	1 $\frac{1}{2}$	$\frac{3}{8}$	$\frac{5}{8}$	$\frac{3}{8}$	2 $\frac{1}{2}$ †	2 $\frac{1}{2}$	1 $\frac{1}{2}$	2 $\frac{1}{2}$
WA16	1615	1 $\frac{1}{2}$	1.5	3 $\frac{1}{4}$	1 $\frac{1}{2}$	$\frac{3}{8}$	$\frac{5}{8}$	$\frac{3}{8}$	2 $\frac{1}{2}$ †	2 $\frac{1}{2}$	2 $\frac{1}{4}$	3
WA25	2517	2 $\frac{1}{2}$	4.0	4 $\frac{1}{4}$	1 $\frac{1}{2}$	$\frac{1}{2}$	$\frac{3}{4}$	$\frac{3}{8}$	4 $\frac{3}{8}$ †	4 $\frac{1}{4}$	3 $\frac{3}{8}$	4 $\frac{1}{4}$
WA30	3030	3	8.6	5 $\frac{1}{2}$	3	$\frac{3}{4}$	$\frac{3}{4}$	$\frac{1}{4}$	5 $\frac{1}{2}$ †	4 $\frac{1}{2}$	4 $\frac{1}{2}$	5
WA35	3535	3 $\frac{1}{2}$	15	6 $\frac{1}{4}$	3 $\frac{1}{2}$	1 $\frac{1}{4}$	1	$\frac{3}{8}$	6 $\frac{1}{4}$ †	5 $\frac{5}{16}$	5	6
WA40	4040	4	29	7 $\frac{1}{4}$	4	1 $\frac{1}{2}$	1	$\frac{3}{8}$	7 $\frac{1}{2}$ †	6 $\frac{1}{2}$	5 $\frac{1}{2}$	7
WA45	4545	4 $\frac{1}{2}$	42	8 $\frac{1}{4}$	4 $\frac{1}{2}$	1 $\frac{1}{2}$	1	$\frac{3}{8}$	8 †	7 $\frac{1}{2}$	6 $\frac{1}{2}$	8
WA50	5050	5	57	9 $\frac{1}{2}$	5	1 $\frac{1}{4}$	1	$\frac{3}{8}$	8 $\frac{1}{2}$ •	8 $\frac{1}{2}$	7	8 $\frac{1}{4}$
WA60	6050	6	115	13 $\frac{1}{4}$	5	1 $\frac{1}{4}$	1 $\frac{1}{4}$		12 $\frac{1}{2}$ ★	11 $\frac{1}{2}$	9 $\frac{1}{4}$	
WA70	7060	7	155	14 $\frac{1}{2}$	6	2 $\frac{1}{4}$	1 $\frac{1}{4}$		13 $\frac{1}{2}$ ★	13 $\frac{1}{4}$	10 $\frac{1}{4}$	
WA80	8065	8	180	15 $\frac{1}{2}$	6 $\frac{1}{2}$	2 $\frac{1}{4}$	1 $\frac{1}{4}$		14 $\frac{1}{2}$ ★	14	11 $\frac{1}{4}$	
WA100	10085	10	340	19 $\frac{1}{2}$	8 $\frac{1}{2}$	3 $\frac{1}{2}$	1 $\frac{1}{2}$		18 $\frac{1}{2}$ ★	18 $\frac{1}{4}$	14 $\frac{1}{4}$	

See dimension tables on preceding page for bushing data and wrench space required.

- † + .000-.002
- + .000-.003
- ★ + .000-.004

Type WA

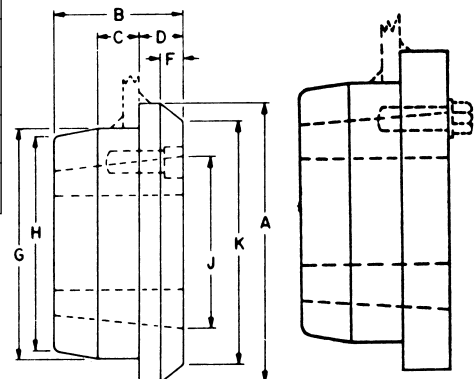

WA12 To WA50

WA60 To WA100

Taper Bushings Metric and Reborable



Stock Taper Bushings With Metric Bores and Keyways

★ Metric Bores	★ Metric Keyway	Taper Bushing Number			
14, 16	5 x 2.3	1008 1215	1108 1610	1210 1615	
18, 19 20, 22	6 x 2.8	1008 1610	1108 1615	1210 2012	1215 2517
24	8 x 3.3	1108 1610	1210 1615	1215 2012	2517
25	8 x 3.3	1210 1615	1215 2012	1610 2517	
28, 30	8 x 3.3	1210 1615	1215 2012	1610 2517	3020
32	10 x 3.3	1610 2012	1615 2517	3020	
35	10 x 3.3	1610 2012	1615 2517	3020	
38	10 x 3.3	1610 2012	1615 2517	3020	
40, 42	12 x 3.3	2012 2517	3020		
45, 48	14 x 3.8	2012 2517	3020		
50 55	14 x 3.8 16 x 4.3	2517 2517	3020 3020		

★ Millimeter Bores and Keyways from ISO Std. R773. 1"= 25.4 millimeters

NOTE: For other metric bore sizes consult factory.

Stock Reborable Taper Bushings With No Keyways

Sintered Steel	Gray Iron	Steel	Stainless Steel
1008 $\frac{9}{16}$ 1108 $\frac{1}{2}$		1008 $\frac{1}{2}$ 1108 $\frac{1}{2}$	1008 $\frac{1}{2}$ 1108
1210 $\frac{9}{16}$ 1215 $\frac{1}{2}$		1210 $\frac{1}{2}$ 1215 $\frac{1}{2}$	1210 $\frac{1}{2}$ 1215
1310 $\frac{1}{2}$ 1610 $\frac{1}{2}$ $1\frac{1}{16}$		1310 1610 $\frac{1}{2}$	1310 1610 $\frac{1}{2}$
1615 $\frac{1}{2}$ $1\frac{1}{16}$ 2012 $\frac{1}{2}$		1615 $\frac{1}{2}$ 2012 $\frac{1}{2}$	1615 $\frac{1}{2}$ 2012 $\frac{1}{2}$
2517 $\frac{1}{2}$ $1\frac{1}{16}$	2525 $2\frac{1}{2}$	2517 $\frac{1}{2}$ 2525	2517 $\frac{1}{2}$ 2525
3020 $1\frac{5}{16}$ $1\frac{11}{16}$	3020 $1\frac{5}{16}$ $1\frac{1}{8}$ $2\frac{1}{16}$ 3030 $1\frac{5}{16}$ $2\frac{1}{8}$ $2\frac{1}{16}$	3020 $1\frac{5}{16}$ 3030	3020 $1\frac{5}{16}$ 3030
	3535 $1\frac{7}{16}$ $2\frac{1}{8}$ $2\frac{1}{16}$ 4040 $1\frac{7}{16}$ $3\frac{3}{16}$ $3\frac{1}{16}$	3535 4040	3535 4040
	4545 $3\frac{1}{16}$ $4\frac{1}{16}$ 5050 $2\frac{7}{16}$ $3\frac{1}{16}$	4545	4545
	6050 $3\frac{3}{16}$ $5\frac{1}{16}$ 7060 $3\frac{1}{16}$		
	8065 $4\frac{1}{16}$ 10085 7		
	120100 8		

★ Not currently stocked. Consult factory for availability and pricing.

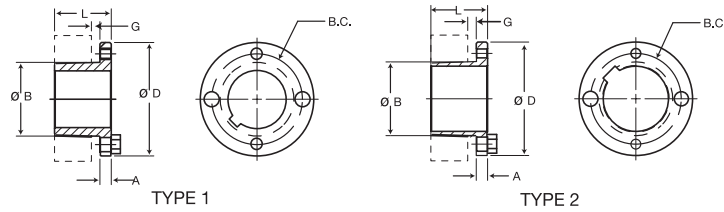

"H" BUSHING

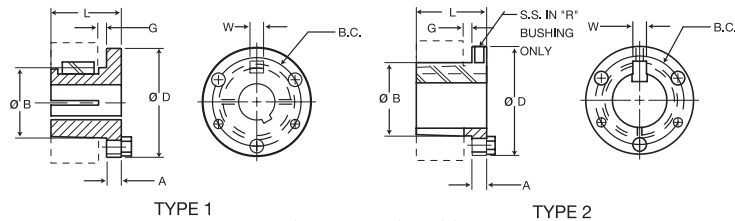

"P", "Q", & "R" BUSHINGS

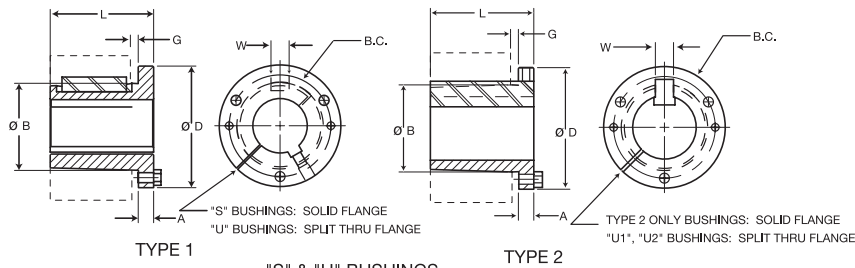

"S" & "U" BUSHINGS

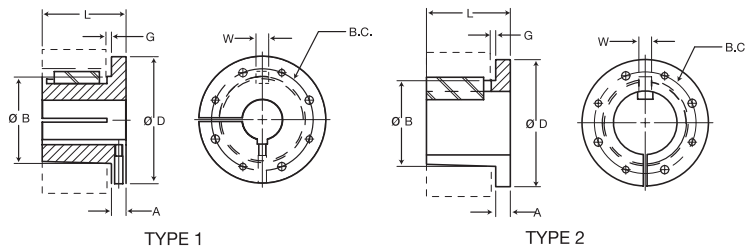

"W" BUSHINGS

Bushing Specifications

Part No.	Dimensions							Stock Bore Range		Cap Screws		Av. Wt. Lbs.	Wrench Torque In. / lbs.
	D	L	A	B Large End	G	B.C.	W	Type 1	Type 2	No.	Size		
H	2.50	1.25	0.25	1.6250	0.19	2.00	—	3/8 - 1-3/8	1-7/16 - 1-1/2	2	1/4X3/4	0.8	95
P1	3.00	1.94	0.41	1.9375	0.22	2.44	0.375	1/2 - 1-7/16	1-1/2 - 1-3/4	3	5/16X1	1.3	192
P2	3.00	2.94	0.41	1.9375	0.22	2.44	0.375	3/4 - 1-7/16	1-1/2 - 1-3/4	3	5/16X1	1.5	192
P3	3.00	4.44	0.41	1.9375	0.22	2.44	0.375	1-1/8 - 1-3/8	1-5/8	3	5/16X1	2	192
Q1	4.12	2.50	0.53	2.8750	0.22	3.38	0.500	3/4 - 2-1/16	2-1/8 - 2-11/16	3	3/8X1-1/4	3.5	348
Q2	4.12	3.50	0.53	2.8750	0.22	3.38	0.500	1 - 2-1/16	2-1/8 - 2-5/8	3	3/8X1-1/4	4.5	348
Q3	4.12	5.00	0.53	2.8750	0.22	3.38	0.500	1-3/8 - 2-1/16	2-1/8 - 2-1/2	3	3/8X1-1/4	5.5	348
R1	5.38	2.88	0.62	4.0000	0.25	4.62	0.750	1-1/8 - 2-13/16	2-7/8 - 3-3/4	3	3/8X1-3/4	7.5	348
R2	5.38	4.88	0.62	4.0000	0.25	4.62	0.750	1-3/8 - 2-13/16	2-7/8 - 3-5/8	3	3/8X1-3/4	11	348
S1	6.38	4.38	0.75	4.6250	0.31	5.38	0.750	1-11/16 - 3-3/16	3-1/4 - 4-1/4	3	1/2X2-1/4	13.5	840
S2	6.38	6.75	0.75	4.6250	0.31	5.38	0.750	1-7/8 - 3-3/16	3-1/4 - 4-3/16	3	1/2X2-1/4	19	840
UO	8.38	5.25	1.06	6.0000	0.44	7.00	1.250	2-3/8 - 3-1/16	—	3	5/8X2-3/4	30	1680
UO	8.38	4.94	0.75	6.0000	0.44	7.00	1.250	3-1/4 - 4-1/4	4-3/8 - 5-1/2	3	5/8X2-3/4	27	1680
U1	8.38	7.12	1.06	6.0000	0.44	7.00	1.250	2-3/8 - 4-1/4	4-3/8 - 5-1/2	3	5/8X2-3/4	40	1680
U2	8.38	10.12	1.06	6.0000	0.44	7.00	1.250	2-7/16 - 4-1/4	4-3/8 - 5	3	5/8X2-3/4	50	1680
W1	12.50	8.25	1.44	8.5000	0.44	10.00	1.250	3-3/8 - 6-3/16	6-1/4 - 7-7/16	4	3/4X3	104	3000
W2	12.50	11.25	1.44	8.5000	0.44	10.00	1.250	3-3/8 - 6-3/16	6-1/4 - 7-7/16	4	3/4X3	133	3000

All tapers are 3/4" per 12" on Dia.

All dimensions are in inches except, as noted.

All bushings are cast iron, ductile iron, sintered steel, or steel. Consult manufacturer for clarification.

Metric bushings also available.

Martin MST BUSHING INSTALLATION & REMOVAL INSTRUCTIONS

The MST bushings are easy to install and remove. They are split through the barrel and have a taper to provide a true clamp on the shaft. They are keyed to both the shaft and the hub to help during "blind" installations.

INSTALLATION

1. Be sure the tapered cone surfaces of the bushing and the inside of the driven product are clean and free of anti-seize lubricants.
2. Place bushing in sprocket or other *Martin* MST part.
3. Place cap screws loosely in pull-up holes. Bushing remains loose to assure sliding fit on shaft.
4. With key on shaft, slide sprocket to desired position on shaft. Be sure heads of capscrews are accessible.
5. Align sprocket. Tighten screws alternately and progressively - until they are pulled up tight (see table below). Do not use extensions on wrench handles. Do not allow sprocket to be drawn in contact with flange of bushing. There should be a gap between bushing flange and sprocket.

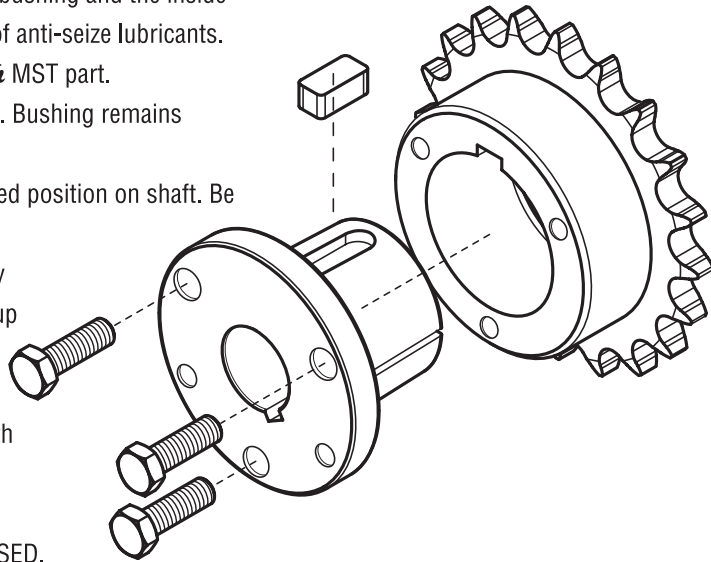

CAUTION: THIS GAP MUST NOT BE CLOSED.

REMOVAL

1. Loosen and remove capscrews.
2. Insert capscrews in tapped removal holes.
3. Tighten inserted screws until sprocket is loose on shaft.
4. Remove sprocket from shaft.



WARNING: USE OF ANTI-SEIZE LUBRICANT ON TAPERED CONE SURFACES OR ON BOLT THREADS WHEN MOUNTING MAY RESULT IN DAMAGE TO SHEAVES AND SPROCKETS. THIS VOIDS ALL MANUFACTURER'S WARRANTIES.

WRENCH TORQUE VALUES FOR TIGHTENING BUSHINGS		
MST Bushing Size	Size of Cap Screw	Wrench Torque in. / lbs.
H	1/4 x 3/4	95
P	5/16 x 1	192
Q	3/8 x 1-1/4	348
R	3/8 x 1-3/4	348
S	1/2 x 2-1/4	840
U	5/8 x 2-3/4	1680
W	3/4 x 3	3000

WARNING: Because of the possible danger to person(s) or property from accidents which may result from the improper use of products, it is important that correct procedures be followed: Products must be used in accordance with the engineering information specified in the catalog. Proper installation, maintenance and operation procedures must be observed. The instructions given above must be followed. Inspections should be made as necessary to assure safe operation under prevailing conditions. All rotating power transmission products when used in a drive are potentially dangerous and must be guarded by the user as required by applicable laws, regulations, standards, and good safety practice. (Refer to ANSI Standard B15.1.)

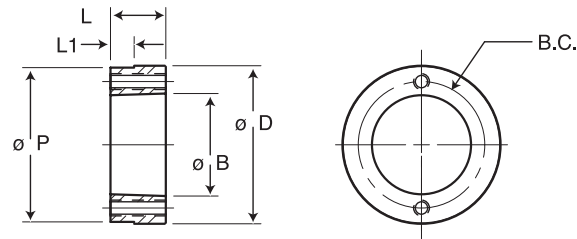

ALL TAPERS 3/4" PER FT.
ON DIAMETER

"H" HUBS

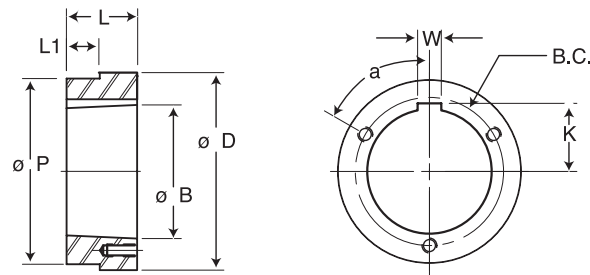

"P", "Q", "R", "S", & "U" HUBS

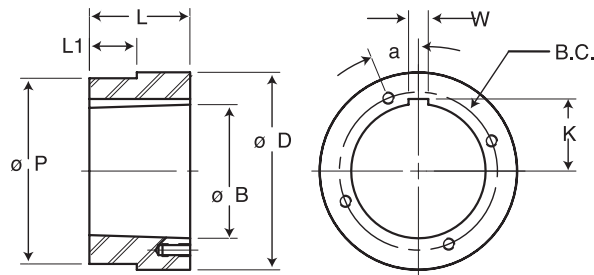

"W" HUBS

Steel Hub Specifications

Part No.	For Bushing	Dimensions										Tapped Holes		Wt. Lbs.
		D	L	P	L1	B	K	B.C.	W	a°	No.	Size		
HH1	H	2.50	0.88	2.375	0.174	1.6210	—	2.000	—	—	2	1/4 - 20	0.6	
HCH1	H	2.50	0.88	2.375	0.625	1.6210	—	2.000	—	—	2	1/4 - 20	0.7	
HP1	P1	3.00	1.31	2.875	0.292	1.9375	1.094	2.438	0.375	60	3	5/16 - 18	1.4	
HCP1	P1	3.00	1.31	2.875	1.000	1.9375	1.094	2.438	0.375	60	3	5/16 - 18	1.1	
HP2	P2	3.00	2.31	2.875	1.100	1.9375	1.094	2.438	0.375	60	3	5/16 - 18	2.5	
HQ1	Q1	4.50	1.75	4.375	0.709	2.8750	1.562	3.375	0.500	60	3	3/8 - 16	4.4	
HCQ1	Q1	4.50	1.75	4.375	1.250	2.8750	1.562	3.375	0.500	60	3	3/8 - 16	4.4	
HQ2	Q2	4.50	2.75	4.375	1.606	2.8750	1.562	3.375	0.500	60	3	3/8 - 16	6.9	
HR1	R1	5.75	2.00	5.625	0.709	4.0000	2.188	4.625	0.750	60	3	3/8 - 16	7.3	
HR2	R2	5.75	4.00	5.625	1.606	4.0000	2.188	4.625	0.750	60	3	3/8 - 16	15.4	
HS1	S1	6.75	3.31	6.500	0.946	4.6250	2.562	5.375	0.750	60	3	1/2 - 13	17.3	
HS2	S2	6.75	5.69	6.500	2.963	4.6250	2.562	5.375	0.750	60	3	1/2 - 13	30.4	
HU0	UO	8.50	3.75	8.250	2.000	6.0000	3.250	7.000	1.250	60	3	5/8 - 11	32.0	
HU1	U1	8.50	5.62	8.250	2.963	6.0000	3.250	7.000	1.250	60	3	5/8 - 11	44.6	
HU2	U2	8.50	8.62	8.250	6.016	6.0000	3.250	7.000	1.250	60	3	5/8 - 11	69.0	
HW1	W1	12.50	6.38	12.250	2.963	8.5000	4.562	10.000	1.250	22.5	4	3/4 - 10	130.0	

All tapers are 3/4" per 12" on Dia.

All dimensions are in inches, except as noted.

QD & MST[®] Idler Bushings

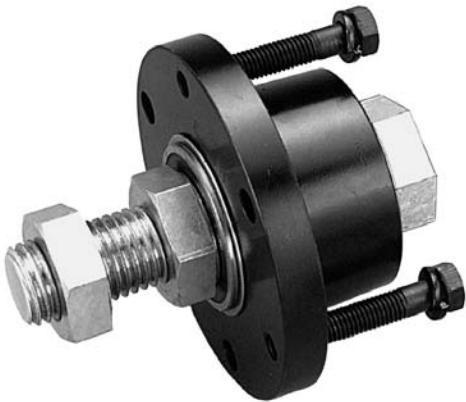

Martin Idler Bushings are designed to accommodate stock V-belt drives, sprockets, timing belt pulleys, or other products that use QD or MST type bushings.

They are equipped with two electric motor grade, permanently lubricated ball bearings, mounted on a precision shoulder bolt. Shoulder bolt and two hex jam nuts are zinc plated.

Installation is made by slipping the threaded shaft through a hole bored in support structure, and tightening the locking nut. Sheaves, sprockets, or other products can be removed without dismounting the idler bushing. Available in sizes as shown below. Boxed complete with all mounting hardware and instructions.

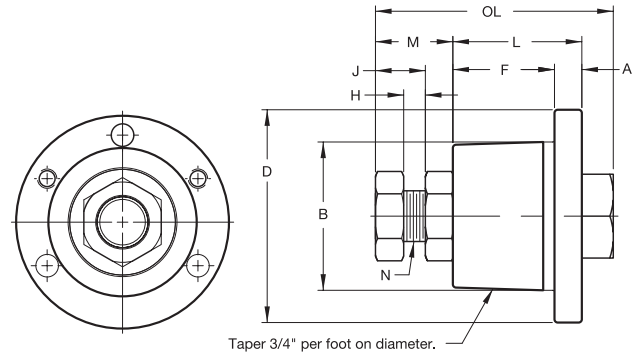
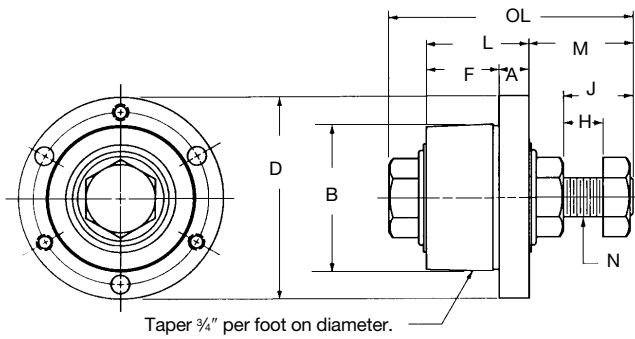

QD Radial Load Ratings (Lbs.) 2500 Hours Service Life

Part Number	RPM				
	100	500	1000	1200	1800
SH-BB	1260	740	580	540	480
SD-BB	1740	1020	800	760	660
SK-BB	2370	1360	1070	1000	880
SF-BB	2550	1500	1180	1100	980
E-BB	4640	2720	2140	2020	1780

Service Temperature Range -40° F Minimum +248° F Maximum

MST Radial Load Ratings (Lbs.) 2500 Hours Service Life

Part Number	RPM				
	100	500	1000	1200	1800
H-BB 1/2	1411	825	655	616	538
P1-BB 5/8	1752	1024	813	765	668
Q1-BB 3/4	2344	1371	1088	1024	894
Q1-BB 1	2555	1494	1186	1116	975

Service Temperature Range -40° F Minimum +248° F Maximum

Part Number	Dimensions									
	A	B	D	F	H	J	L	M	N	OL
SH-BB	7/16	1.871	2 1/16	3/4	5/8	1 1/16	1 1/8	1 1/16	3/8	3 1/8
SD-BB	1/2	2.187	3 3/16	1 1/4	1 1/16	1 1/8	1 1/8	1 1/16	5/8	3 3/8
SK-BB	9/16	2.812	3 3/8	1 1/2	3/4	1 3/8	1 5/8	1 3/8	3/4	4 1/8
SF-BB	5/8	3.125	4 3/8	1 3/4	3/4	1 1/2	2 1/8	2 1/8	7/8	5
E-BB	3/4	3.834	6	1 7/8	1 1/8	2 1/8	2 3/8	3 3/8	1 1/2	6 3/8
H-BB 1/2	1/4	1.625	2 1/2	1	3/8	1 1/16	1 1/4	1	1/2	2 1/8
P1-BB 5/8	1 3/16	1.937	3	1 1/32	1 1/32	5/8	1 1/8	1 1/8	5/8	3 1/4
Q1-BB 3/4	1 1/32	2.875	4 1/8	1 15/16	5/8	2 1/8	2 1/2	1 1/4	3/4	4 7/32
Q1-BB 1	1 1/32	2.875	4 1/8	1 15/16	9/32	5 7/64	2 1/2	1 1/2	1	4 39/64