

PRODUCT	COUPLINGS	PAGE
INDEX		C-1
COUPLING COMPARISON		C-2
QUADRA-FLEX®		C-4 – C-24
Sleeve Selection		C-7 – C-8
Selection Procedure		C-9
Sleeves		C-14
Flanges		C-15 – C-19
Keyseat Dimensions		C-18
Spacer Flanges		C-20 – C-23
Installation		C-24
CHAIN COUPLING		C-25 – C-27
Bored-To-Size		C-26
QD		C-26
Taper Bushed		C-26
Coupling Selection		C-27
Plain Bore		C-27
Covers		C-27
JAW COUPLING		C-28 – C-30
Horsepower Ratings		C-29
ML & MS Hubs		C-30
ML & MS Spiders		C-30
<i>Martin</i> -FLEX®		C-31 – C-32
Stock Sizes		C-31
Engineering		C-32



Conmutador: +52(55) 5305-1320
 Fax: +52(55) 5305-1326
 Nextel ID: 52*40085*2
 Lada sin Costo México: 01800 552 9428
 mail: ventas@rodamientos-samper.com.mx

Coupling Comparison

COUPLINGS

Couplings Comparison Chart

Type	Connecting Medium	Max. H. P. Per 100 RPM	Max. RPM	Bore Range	Allowable Misalignment	
					Angle	Parallel
CHAIN	ROLLER CHAIN	700	5000	3/8" – 6 1/8"	2°	.015
JAW	ELASTOMERIC SPIDER	3.6	3600	1/8" – 2 5/8"	1°	.015
<i>Martin</i> FLEX®	ELASTOMERIC TIRE	14.4	4500	3/8" – 3 1/2"	4°	1/8"
QUADRA FLEX®	ELASTOMERIC SLEEVE	115	9200	1/2" – 6"	.330°	.062

Type	Shock Load Capacity	Vibration Dampening	Temperature	
			Range	Fahrenheit
CHAIN	NONE	NONE	-30°	225°
JAW	MODERATE	MODERATE	-60°	250° ★1
<i>Martin</i> FLEX®	EXCELLENT	EXCELLENT	-45°	210° ★2
QUADRA-FLEX®	EXCELLENT	EXCELLENT MODERATE	-50°	275° ★3
			-30°	275° ★4

- ★1 With Hytrel® Spider
- ★2 Neoprene Element
- ★3 TPR Sleeve
- ★4 With EPDM Sleeve

Whatever Your Need For Couplings — *Martin* Has Them

Martin Offers Two Complete Lines of Jaw Couplings — One for Greater Horsepower and One for Interchangeability.



ML — Type



MS — Type



Martin-Flex® flexible couplings smoothly transmit power while compensating for shaft misalignment to 4°, parallel misalignment to 1/8" and end float to 5/16". The two piece flange design provides quick and easy installation and the elastomeric element absorbs shock and torsional vibration through a wide temperature range.

For the Most Complete Line of Chain Couplings Available.



S/B



BS



TB



QD



Aluminum



Plastic

Martin QUADRA-FLEX® • A Proven Design Which Offers Long Life, Torsional Flexibility, Ease of Installation, and Withstands Misalignment, Shock, and Vibration.



QUADRA-FLEX®
4-Way Flexing

Martin

Quadra-Flex® FLEXIBLE COUPLINGS



Stocked Nationwide
In Sizes 3 Through 16

Styles J, S, B, and
SC Spacers

COUPLINGS

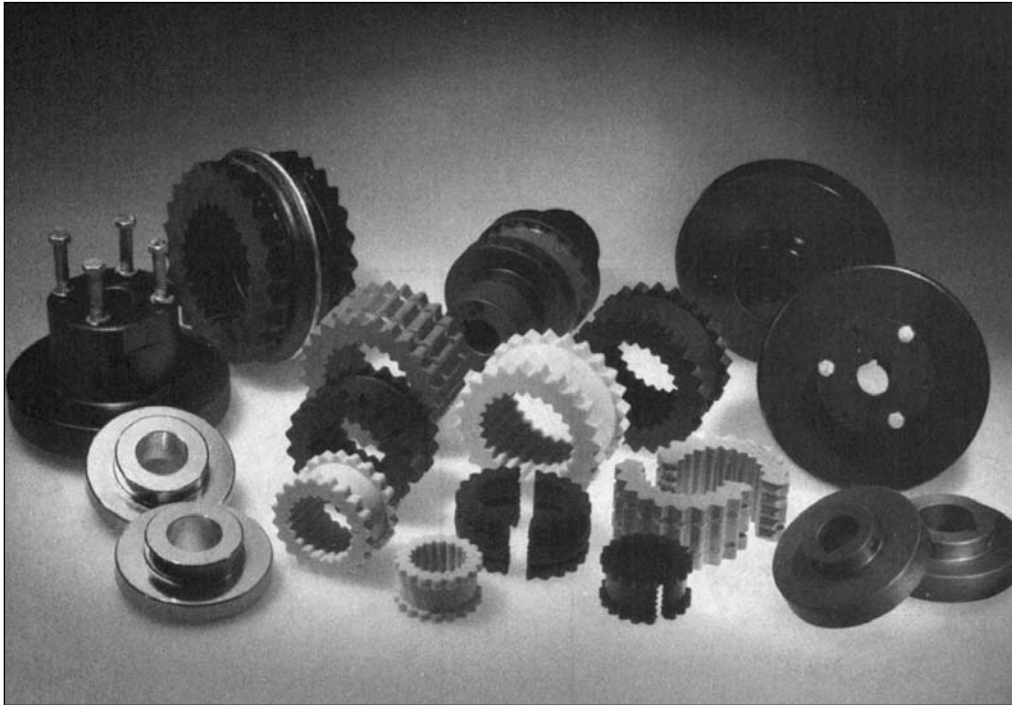

Martin QUADRA-FLEX® Couplings, Non Lubricated,
Maintenance Free, Easy and Quick Installation

Handles All Combinations of Shock, Vibration, and Misalignment

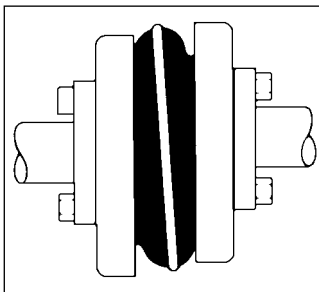

Parallel

QUADRA-FLEX® couplings absorb parallel misalignment without wear and with minimal loss of energy. The amount of parallel offset handled varies by size from .015" on the size 5 up to .062" on the size 16. This minimizes the radial loads on bearings when parallel misalignment occurs.

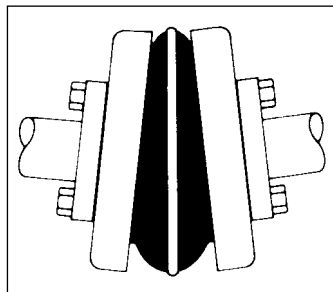

Angular

Due to the flexing characteristics of the sleeve and the locking action of the teeth, QUADRA-FLEX® couplings easily handle angular misalignment up to 1 degree without any appreciable wear.

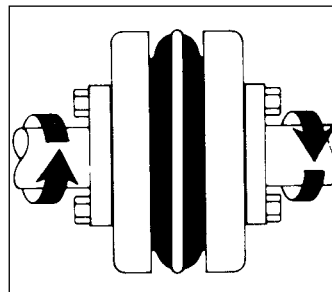

Torsional

QUADRA-FLEX® sleeves are torsionally resilient and are well suited to absorbing shocks and dampening vibrations that would otherwise be transmitted between the equipment.

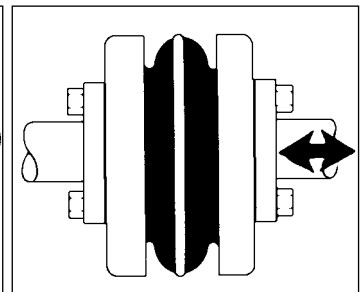

Axial

The axial flexibility of the sleeve allows the QUADRA-FLEX® coupling to accept a limited amount of end float. This serves to reduce thrust loads transferred to bearings. QUADRA-FLEX® units will accept axial movement of approximately 1/8".

Available in Three Styles

Type J and S Flanges

Bored-to-size flanges are manufactured for a slip fit on standard shafting. Available from stock in a wide range of shaft sizes.



Type B Flanges

Manufactured from high strength cast iron to fit standard QD bushings in sizes 6 thru 16.



Fast Coupling Disassembly

Martin offers the first true drop-out spacer assembly for the 4JSC spacer coupling. The center portion of the spacer can be taken out, just as in the 5SC thru 14SC, by simply removing four cap screws in each hub. The couplings center section can then be lifted out and the pump gaskets exposed. Flats on the spacer hubs facilitate turning shafts with a wrench.



Type SC Spacer Flange

QUADRA-FLEX® SC Spacer Couplings feature all standard spacing requirements for the pump industry. Spacer sizes range from sizes 4 thru 14.



QUADRA-FLEX® Nomenclature

Flanges

Type	Description
J★	SINTERED STEEL, BORED-TO-SIZE
S	CAST IRON, BORED-TO-SIZE
B	CAST IRON, QD BUSHED
SC	SPACER COUPLING FLANGES

★ – #6 Currently Supplied in Cast Iron

Hubs – (For SC flanges)

Type	Description
H	REGULAR LENGTH
HS	SHORT LENGTH

Sleeves

Type	Description
JEM	TPR – 1-PIECE SOLID, THERMOPLASTIC
JEMS	TPR – 1-PIECE SPLIT, THERMOPLASTIC
EM	TPR – 2-PIECE W/RETAINING RING
E	EPDM – 2-PIECE W/RETAINING RING
N	NEOPRENE – 2-PIECE W/RETAINING RING
H	HYTREL – 1-PIECE SOLID
HS	HYTREL – 2-PIECE

QUADRA-FLEX® couplings come in a variety of styles and designs to meet specific customer needs. These include flanges and sleeves of various types and materials. The total product line includes 13 sizes varying in torque ratings up to 72,000 in-lbs.

When ordering QUADRA-FLEX® couplings, the following basic procedure should help expedite order processing. For coupling flanges, give the basic coupling size, then the letter for the type flange followed by the bore size required. For coupling sleeves, give the coupling size followed by the letter(s) designating the type and material required. (See above)

The following are various examples for reference:

Example: Type J Flange

	Size	Flange	Bore
5J x 3/4"	5	J	3/4"
7S x 30mm	7	S	30mm

(Note: Bored-to-size flanges are furnished with standard keyway and 2 setscrews unless specified otherwise.)

Example: Type B Flange

	Size	Flange	Bushing
8B – SH	8	B	SH

(Note: The SH bushing with required bore size should be specified separately.)

Example: Sleeves

	Size	Style & Material
8JEM	8	Solid, TPR
13E	13	2 Piece, EPDM

(Note: Unless specified, TPR (3 thru 12) or EPDM (13 thru 16) will be supplied.)

Example: Complete spacer coupling

1	6EM	(6 TPR 2 Piece Sleeve)
2	6SC35	(Flanges for 3 1/2" dropout)
1	6H x 1"	(6 Spacer Hub for 1" Bore)
1	6H x 1 1/8"	(6 Spacer Hub for 1 1/8" Bore)

Sleeve Selection



COUPLINGS

QUADRA-FLEX® coupling sleeves are available in four different types of compounds. These include TPR (ThermoPlastic Rubber) in types JEM, JEMS, EM; EPDM

Rubber in type E; Neoprene in type N; Hytrel in type H and HS. To determine the sleeve best suited for the application, the material characteristics are given below.

TPR (Sizes 3-12)

QUADRA-FLEX® couplings are usually supplied with TPR sleeves in sizes 3-12. TPR is a general use sleeve which combines the characteristics of both EPDM & Neoprene into one. These sleeves operate within a temperature range from -50° F to +275° F (-46° C to +135° C). Torsional flexibility is 15°.

EPDM (Sizes 13-16)

QUADRA-FLEX® couplings are usually supplied with EPDM rubber sleeves in sizes 13-16. EPDM is a general use sleeve and can operate within a temperature range from -30° F to +275° F (-34° C to +135° C). Torsional flexibility is 15°.

NEOPRENE (Sizes 11-16)

Neoprene flexible sleeves are also available in sizes 11-14. These sleeves offer a higher resistance than EPDM and are self-extinguishing. Operating temperature range for this sleeve is 0° F to +200° F (-18° C to +93° C). Torsional flexibility is 15°.

*HYTREL® (Sizes 6-14)

Hytrel sleeves are molded specifically for high torque applications. The type H will transmit approximately four times as much power as an equivalent TPR, EPDM, or Neoprene sleeve. Hytrel has an operating temperature from -65° F to +250° F (-54° C to +121° C). Torsional flexibility is 7°.

Note: Do not use a Hytrel sleeve as a replacement for a TPR, EPDM, or Neoprene sleeve.

Sleeve Chemical Resistance

Resistance To:	TPR	EPDM	Neoprene★	Hytrel★	Resistance To:	TPR	EPDM	Neoprene★	Hytrel★
Acetone	A	A	B	B	Isopropyl	A	T	A	A
Ammonia, Anhydrous	B	T	A	N	Kerosene	B	X	B	T
Ammonium Hydroxide Solutions	T	A	A(158F)	T	Lacquer Solvents	T	...	C	B
ASTM hydrocarbon test fluid	N	C	X	A	Lubricating Oils	B	X	B(158F)	A
ASTM oil no. 1	B	C	A	A	Methyl Alcohol	A	T	A(158F)	A
ASTM oil no. 3	B	C	B(158F)	A	Mineral Oil	B	X	A	A
ASTM reference fuel A	B	C	A	A	Naphtha	B	C	C	A
ASTM reference fuel B	B	C	C	A	Nitric Acid, 10%	A	T	B	B
ASTM reference fuel C	B	X	C	B	Nitrobenzene	T	A	C	C
Benzene	C	C	C	B	Phenol	T	T	B	C
Butane	B	B	A	A	Phosphoric Acid, 20%	A	T	T	N
Carbon Tetrachloride	X	C	C	C	Phosphate Esters	A	A	C	A
Chlorobenzene	C	X	X	X	Pickling Solution (20% Nitric Acid, 4% HF)	N	X	B-C	X
Chloroform	X	C	C	C	Soap Solutions	A	T	A(158F)	A
Chromic Acid, 10-50%	T	T	C	N	Sodium Hydroxide, 20%	A	A	A	A
Dowtherm A Solvent	X	N	B	N	Stearic Acid	T	T	B(158F)	T
Ethyl Alcohol	A	A	A(158F)	A	Sulfuric Acid, up to 50%	A	T	A(158F)	A
Ethylene Glycol	A	A	A(158F)	A	Sulfuric Acid, up to 80%	A	T	B-C	C
Fuel Oil	B	X	A	A	Tannic Acid, 10%	T	T	A	T
Gasoline	B	B-C	B	A	Toluene	C	C	C	B
Glycerine	A	T	A(158F)	A	Trichloroethylene	C	X	C	C
Hydraulic Oils	B	N	A	A	Turpentine	B	C	C	N
Hydrochloric Acid, 20%	A	T	A	B	Water	A	A(158F)	A(212F)	A(158F)
Hydrogen Peroxide, 88½%	N	T	B	T	Xylene	C	C	X	B

A — Fluid has little or no effect
 B — Fluid has minor to moderate effect
 C — Fluid has severe effect

N — No evaluation has been attempted.
 T — No data; likely to be compatible
 X — No data; not likely to be compatible

*Hytrel is a Registered Trademark of Dupont

Selection Procedure

When the driver is an electric motor with standard speed.

Step 1. Determine Service Factor (SF) Symbol based on equipment listed on page C-10.

Step 2. Determine proper Service Factor from chart at top of page C-10.

Step 3. Refer to page C-12 and C-13 for proper selection of coupling. Based on chemical resistance and operating environment found on page C-8, select from chart the type of sleeve material. Find RPM of motor, then, in the column for service factor determined in Step 2, read down to the corresponding horsepower of motor being used as the driver. The number listed is the correct coupling size.

Example: A coupling is needed to connect a 25 HP standard electric motor to a lumber log haul at 1750 RPM.

1. Service Factor Symbol — H
2. Service Factor — 2.0
3. Coupling Size — 9 with TPR sleeve or 6 with Hytrel Sleeve

Step 4. Select flanges from pages C-15 thru C-19, check coupling bore size range for proper shaft fit.

★ **NOTE: Do not oversize coupling hub — will cause premature wear of element.**

When the driver is other than an electric motor or the speeds are different than those shown in the chart on page C-11.

Step 1. Follow steps 1 & 2 in previous procedure.

Step 2. Calculate Horsepower at 100 RPM as follows:

$$\text{HP at 100 RPM} = \frac{\text{HP} \times \text{Service Factor} \times 100}{\text{coupling RPM}}$$

Step 3. Select coupling size from Tables A or C. Find a HP equal to or greater than the HP/100 RPM

Step 4. Check Maximum bore to be sure that both shaft sizes do not exceed figure listed for size selected in step 4. If maximum is exceeded select the next largest size which will allow for bore size. Do not exceed maximum RPM for new size selected.

Example: A bucket elevator is driven by a motor/reducer and requires a coupling to transmit 14 HP at 1300 RPM.

1. Service Factor Symbol — M
2. Service Factor — 1.5
3. HP at 100 RPM = $\frac{14 \times 1.5 \times 100}{1300} = 1.61$ HP/100 RPM
4. Refer to page C-11; under column for 100 RPM the required 1.61 HP falls between the size 7 (1.2) and the size 8 (1.8). Correct selection is size 8 with TPR sleeve. Check bore sizes for flanges on pages C-15 thru C-19.

Maximum RPM and Allowable Misalignment

Size	Maximum RPM	Types JEM, JEMS, EM, E and N		Types H and HS	
		Parallel	Angular	Parallel	Angular
3	9200	.010	.035	—	—
4	7600	.010	.043	—	—
5	7600	.015	.056	—	—
6	6000	.015	.070	.010	.016
7	5250	.020	.081	.012	.020
8	4500	.020	.094	.015	.025
9	3750	.025	.109	.017	.028
10	3600	.025	.128	.020	.032
11	3600	.032	.151	.022	.037
12	2800	.032	.175	.025	.042
13	2400	.040	.195	.030	.050
14	2200	.045	.242	.035	.060
16	1500	.062	.330	—	—

Note: Values shown above apply if the actual torque transmitted is more than ¼ the coupling rating. For lesser torque, reduce the above values by ¼.

Service Factors For QUADRA-FLEX® Couplings

Service Factor Symbol	Electric Motor Standard Torque	Electric Motor High Torque	Turbines	Reciprocating Engines
L (LIGHT)	1.25	1.5	1.0	1.5
M (MEDIUM)	1.5	2.0	1.25	2.0
H (HEAVY)	2.0	2.5	1.5	2.5

Table 1

Application	SF Symbols	Application	SF Symbols	Application	SF Symbols
AGITATORS - Paddle, Propeller, Screw	L	DISC FEEDER	L	MILLS	
BAND RESAW	M	DOUGH MIXER	M	Ball, Pebble, Rod, Tube	H
BARGE HAUL PULLER	H	DRAW BENCH CONVEYOR & Main Drive	H	Rubber, Tumbling	H
BARKING (Lumber)	H	DREDGES		Dryer and Cooler	M
BAR SCREEN (sewage)	L	Cable Reel, Pumps	M	MIXER	
BATCHES (textile)	L	Cutter Head Drive, Jig Drive	H	Concrete, Muller	M
BEATER AND PULPER (paper)	M	Screen Drive	H	Banbury	H
BENDING ROLL (metal)	M	Maneuvering and Utility Winch	M	ORE CRUSHER	H
BLEACHER (paper)	L	Stacker	M	OVEN CONVEYOR	L
BLOWERS		DYNAMOMETER	L	PLANER (metal or wood)	M
Centrifugal, Vane	L	DRYERS (rotary)	M	PRESSES	
Lobe	M	EDGER (lumber)	H	Brick, Briquette Machine	H
BOTTLING MACHINERY	L	ELEVATORS		Notching, Paper, Punch, Printing	M
BREW KETTLES (distilling)	L	Bucket	M	PUG MILL	M
BUCKET ELEVATOR OR CONVEYOR	M	Escalator	L	PULP GRINDER (paper)	H
CALENDERS		Freight, Passenger, Service, Man Lift	H	PULVERIZERS	
Calender (paper)	M	ESCALATORS	L	Hammermill — light duty, Roller	M
Calender-super (paper, rubber)	H	EXTRUDER (metal)	H	Hammermill — heavy duty, Hog	H
CANE KNIVES (sugar)	M	FANS		PUMPS	
CARD MACHINE (textile)	H	Centrifugal	L	Centrifugal, Axial	L
CAR DUMPERS	H	Cooling Tower	H	Gear, Lobe, Vane	M
CEMENT KILN	H	Forced Draft, Large Industrial, Mine	M	Reciprocating — sgl. or dbl. acting	*
CENTRIFUGAL BLOWERS		FEEDERS		REEL, REWINDER (paper) CABLE	M
COMPRESSORS, FANS or PUMPS	L	Apron, Belt, Disc	L	ROD MILL	H
CHEMICAL FEEDERS (sewage)	L	Reciprocating	H	SAWDUST CONVEYOR	L
CHILLER (oil)	M	Screw	M	SCREENS	
CHIPPER (paper)	H	FILTER, PRESS-OIL	M	Air Washing, Water	L
CIRCULAR RESAW	M	GENERATORS		Rotary for coal or sand	M
CLARIFIER or CLASSIFIER	L	Uniform load	L	Vibrating	H
CLAY WORKING MACHINERY	M	Varying load, Holst.	M	SCREW CONVEYOR	L
COLLECTORS (sewage)	L	Welders	H	SLAB CONVEYOR (lumber)	M
COMPRESSORS		GRIT COLLECTOR (sewage)	L	SLITTERS (metal)	M
Centrifugal	L	GRIZZLY	H	SOAPERS (textile)	L
Reciprocating	*	HAMMERMILL		SORTING TABLE (lumber)	M
Screw, Lobe	L	Light Duty, Intermittent	M	SPINNER (textile)	M
CONCRETE MIXERS	M	Heavy Duty, Continuous	H	STOKER	L
CONVERTING MACHINE (paper)	M	HOISTS		SUCTION ROLL (paper)	M
CONVEYORS		Heavy Duty	H	TENTER FRAMES (textile)	M
Apron, Assembly Belt, Flight	L	Medium Duty	M	TIRE BUILDING MACHINES	H
Oven, Screw	L	JORDAN (paper)	H	TIRE & TUBE PRESS OPENER	L
Bucket	L	KILN, ROTARY	H	TUMBLING BARRELS	H
COOKERS- Brewing, Distilling, Food	L	LAUNDRY WASHER or TUMBLER	H	WASHER and THICKENER (paper)	M
COOLING TOWER FANS	H	LINE SHAFTS	L	WINCHES	M
COUCH (paper)	M	LOG HAUL (lumber)	H	WINDERS, Paper, Textile, Wire	M
CRANES & HOISTS	M	LOOM (textile)	M	WINDLASS	M
Heavy Duty Mine	H	MACHINE TOOLS, MAIN DRIVE	M	WIRE	
CRUSHERS — Cane (sugar), Stone, Ore	H	MANGLE (textile)	L	Drawing	H
CUTTER — Paper	H	MASH TUBS (distilling)	L	Winding	M
CYLINDER (paper)	H	MEAT GRINDER	M	WOODWORKING MACHINERY	L
DEWATERING SCREEN (sewage)	M	METAL FORMING MACHINES	M		

* Consult Factory

Coupling Ratings

Table 2A ThermoPlastic Rubber (TPR), EPDM & Neoprene

Coupling Size	Sleeve Construction	Basic HP Ratings Per Given RPM					Rated Torque (in.-lb.)	Torsional • Stiffness Factor (in.-lb./radians)	Maximum RPM
		100	860	1160	1750	3500			
3	TPR	.10	.8	1.1	1.7	3.3	60	229	9200
4	TPR	.19	1.6	2.2	3.3	6.7	120	458	7600
5	TPR	.38	3.3	4.4	6.7	13.0	240	916	7600
6	TPR	.71	6.1	8.3	12.5	25.0	450	1718	6000
7	TPR	1.20	10.0	13.0	20.0	40.0	725	2769	5250
8	TPR	1.80	16.0	20.0	32.0	63.0	1135	4335	4500
9	TPR	2.80	25.0	33.0	50.0	100.0	1800	6875	3750
10	TPR	4.60	39.0	53.0	80.0	160.0	2875	10980	3600
11	TPR	7.20	62.0	83.0	126.0	252.0	4530	17300	3600
12	TPR	11.40	98.0	132.0	200.0	—	7200	27500	2800
13	EPDM & Neoprene	18.00	155.0	209.0	315.0	—	11350	43350	2400
14	EPDM & Neoprene	28.60	246.0	331.0	500.0	—	18000	68755	2200
16	EPDM	75.00	645.0	870.0	—	—	47250	180480	1500

Table 2C Hytrel

Coupling Size	Sleeve Construction	Basic HP Ratings Per Given RPM					Rated Torque (in.-lb.)	Torsional • Stiffness Factor (in.-lb./radians)	Maximum RPM
		100	860	1160	1750	3500			
3*	HYTREL	—	—	—	—	—	—	—	—
4*	HYTREL	—	—	—	—	—	—	—	—
5*	HYTREL	—	—	—	—	—	—	—	—
6	HYTREL	2.9	25.0	33.0	50.0	100.0	1800	10000	6000
7	HYTREL	4.6	39.0	53.0	80.0	160.0	2875	20000	5250
8	HYTREL	7.2	62.0	84.0	126.0	252.0	4530	30000	4500
9	HYTREL	11.4	98.0	132.0	200.0	400.0	7200	47500	3750
10	HYTREL	18.0	155.0	209.0	315.0	630.0	11350	100000	3600
11	HYTREL	28.6	246.0	331.0	500.0	1000.0	18000	125000	3600
12	HYTREL	50.0	430.0	580.0	875.0	—	31500	225000	2800
13	HYTREL	75.0	645.0	870.0	1312.0	—	47268	368900	2400
14	HYTREL	115.0	986.0	1334.0	2013.0	—	72480	593250	2200

- Hytrel sleeves are available on a made-to-order basis. Consult factory.
- Values shown are for an ambient temperature of 75° F (24° C).

Sleeve Selection Chart



Selection Chart for TPR¹, EPDM, & Neoprene Sleeves

HP	860 RPM Motor					1160 RPM Motor					1750 RPM Motor					3500 RPM Motor				
	Service Factors					Service Factors					Service Factors					Service Factors				
	1.0	1.25	1.5	2.0	2.5	1.0	1.25	1.5	2.0	2.5	1.0	1.25	1.5	2.0	2.5	1.0	1.25	1.5	2.0	2.5
½	3	3	3	4	4	3	3	3	3	4	3	3	3	3	3	—	—	—	—	—
¾	3	4	4	4	5	3	3	4	4	4	3	3	3	3	4	3	3	3	3	3
1	4	4	4	5	5	3	4	4	4	5	3	3	3	4	4	3	3	3	3	3
1½	4	5	5	5	6	4	4	5	5	5	3	4	4	4	5	3	3	3	3	4
2	5	5	5	6	6	4	5	5	5	6	4	4	4	5	5	3	3	3	4	4
3	5	6	6	6	7	5	5	6	6	6	4	5	5	5	6	3	4	4	4	5
5	6	6	7	7	8	6	6	6	7	7	5	5	6	6	6	4	4	5	5	5
7½	7	7	8	8	9	6	7	7	8	8	6	6	6	7	7	5	5	5	6	6
10	7	8	8	9	9	7	7	8	8	9	6	6	7	7	8	5	5	6	6	6
15	8	9	9	10	10	8	8	9	9	10	7	7	8	8	9	6	6	6	7	7
20	9	9	10	10	11	8	9	9	10	10	7	8	8	9	9	6	6	7	7	8
25	9	10	10	11	11	9	9	10	10	11	8	8	9	9	10	6	7	7	8	8
30	10	10	11	11	12	9	10	10	11	11	8	9	9	10	10	7	7	8	8	9
40	10	11	11	12	12	10	10	11	11	12	9	9	10	10	11	7	8	8	9	9
50	11	11	12	12	13	10	11	11	12	12	9	10	10	11	11	8	8	9	9	10
60	11	12	12	13	13	11	11	12	12	13	10	10	11	11	12	8	9	9	10	10
75	12	12	13	13	14	11	12	12	13	13	10	11	11	12	12	9	9	10	10	11
100	12	13	13	14	14	12	12	13	13	14	11	11	12	12	13	9	10	10	11	11
125	13	13	14	14	—	12	13	13	14	14	11	12	12	13	13	10	10	11	11	—
150	13	14	14	16	16	13	13	14	14	16	12	12	13	13	14	10	11	11	—	—
200	14	14	16	16	16	13	14	14	16	16	12	13	13	14	14	11	11	—	—	—
250	14	16	16	16	16	14	14	16	16	16	13	13	14	14	—	11	—	—	—	—
300	16	16	16	16	—	14	16	16	16	16	13	14	14	—	—	—	—	—	—	—
350	16	16	16	—	—	16	16	16	16	16	14	14	—	—	—	—	—	—	—	—
400	16	16	16	—	—	16	16	16	16	—	14	14	—	—	—	—	—	—	—	—
450	16	16	—	—	—	16	16	16	—	—	14	—	—	—	—	—	—	—	—	—
500	16	16	—	—	—	16	16	16	—	—	14	—	—	—	—	—	—	—	—	—
600	16	—	—	—	—	16	16	—	—	—	—	—	—	—	—	—	—	—	—	—
700	—	—	—	—	—	16	16	—	—	—	—	—	—	—	—	—	—	—	—	—
800	—	—	—	—	—	16	—	—	—	—	—	—	—	—	—	—	—	—	—	—

¹ ThermoPlastic Rubber

Caution: Applications involving reciprocating engines and reciprocating driven devices are subject to critical rotational speeds which may damage the coupling and/or connected equipment. Contact factory with specific requirements.



Hytrell Selection Chart

Selection Chart for Hytrell Sleeves

HP	860 RPM Motor					1160 RPM Motor					1750 RPM Motor					3500 RPM Motor									
	Service Factors					Service Factors					Service Factors					Service Factors									
	1.0	1.25	1.5	2.0	2.5	1.0	1.25	1.5	2.0	2.5	1.0	1.25	1.5	2.0	2.5	1.0	1.25	1.5	2.0	2.5					
1																									
1½																									
2																									
3																									
5																									
7½	6H	6H	6H	6H	6H	—	—	—	—	—	—	—	—	—	—	—	—	—	—	—	—	—	—	—	
10	6H	6H	6H	6H	6H	6H	6H	6H	6H	6H	—	—	—	—	—	—	—	—	—	—	—	—	—	—	
15	6H	6H	6H	7H	7H	6H	6H	6H	6H	7H	6H	6H	6H	6H	6H	6H	—	—	—	—	—	—	—	—	
20	6H	6H	7H	7H	8H	6H	6H	6H	7H	7H	6H	6H	6H	6H	6H	6H	—	—	—	—	—	—	—	—	
25	6H	7H	7H	8H	8H	6H	6H	7H	7H	8H	6H	6H	6H	6H	7H	—	—	—	—	—	—	—	—	—	
30	7H	7H	8H	8H	9H	6H	7H	7H	8H	8H	6H	6H	6H	7H	7H	6H	6H	6H	6H	6H	6H	6H	6H	6H	
40	7H	8H	8H	9H	9H	7H	7H	8H	8H	9H	6H	6H	7H	7H	8H	6H	6H	6H	6H	6H	6H	6H	6H	6H	
50	8H	8H	9H	9H	10H	7H	8H	8H	9H	9H	6H	7H	7H	8H	8H	6H	6H	6H	6H	6H	6H	6H	6H	7H	
60	8H	9H	9H	10H	10H	8H	8H	9H	9H	10H	7H	7H	8H	8H	9H	6H	6H	6H	6H	7H	7H	7H	7H	7H	
75	9H	9H	10H	10H	11H	8H	9H	9H	10H	10H	7H	8H	8H	9H	9H	6H	6H	7H	7H	8H	8H	8H	8H	8H	
100	9H	10H	10H	11H	11H	9H	9H	10H	10H	11H	8H	8H	9H	9H	10H	6H	7H	7H	8H	8H	8H	8H	8H	8H	
125	10H	10H	11H	11H	12H	9H	10H	10H	11H	11H	8H	9H	9H	10H	10H	7H	7H	8H	8H	9H	9H	9H	9H	9H	
150	10H	11H	11H	12H	12H	10H	10H	11H	11H	12H	9H	9H	10H	10H	11H	7H	8H	8H	9H	9H	9H	9H	9H	9H	
200	11H	11H	12H	12H	13H	10H	11H	11H	12H	12H	9H	10H	10H	11H	11H	8H	8H	9H	9H	10H	10H	10H	10H	10H	
250	11H	12H	12H	13H	13H	11H	11H	12H	12H	13H	10H	10H	11H	11H	12H	8H	9H	9H	10H	10H	10H	10H	10H	10H	
300	12H	12H	13H	13H	14H	11H	12H	12H	13H	13H	10H	11H	11H	12H	12H	9H	9H	10H	10H	11H	11H	11H	11H	11H	
350	12H	12H	13H	14H	14H	12H	12H	12H	13H	14H	11H	11H	12H	12H	12H	9H	10H	10H	11H	11H	11H	11H	11H	11H	
400	12H	13H	13H	14H	14H	12H	12H	13H	13H	14H	11H	11H	12H	12H	13H	9H	10H	10H	11H	11H	11H	11H	11H	11H	
500	13H	13H	14H	14H	—	12H	13H	13H	14H	14H	11H	12H	12H	13H	13H	10H	10H	11H	11H	—	—	—	—	—	
600	13H	14H	14H	—	—	13H	13H	13H	14H	—	12H	12H	13H	13H	14H	10H	11H	11H	—	—	—	—	—	—	
700	14H	14H	—	—	—	13H	13H	14H	14H	—	12H	12H	13H	14H	14H	11H	11H	—	—	—	—	—	—	—	
800	14H	14H	—	—	—	13H	14H	14H	—	—	12H	13H	13H	14H	14H	11H	11H	—	—	—	—	—	—	—	
900	14H	—	—	—	—	14H	14H	14H	—	—	13H	13H	14H	14H	—	11H	—	—	—	—	—	—	—	—	
1000	—	—	—	—	—	14H	14H	—	—	—	13H	13H	14H	14H	—	11H	—	—	—	—	—	—	—	—	

Sleeves

QUADRA-FLEX® Sleeves

Martin flexible sleeve elements are offered in four material compounds (ThermoPlastic Rubber (TPR), EPDM, Neoprene, and Hytrel) available in three construction styles. Our EM sleeve offers the combination of EPDM's extended temperature range as well as the higher oil resistance which Neoprene provides.

COUPLINGS



Type JEM

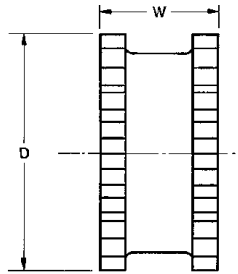

Type JEMS

Types JEM — JEMS

Type J sleeves are molded ThermoPlastic Rubber (TPR). Available in 1 piece solid (JEM), and 1 piece split, construction (JEMS). TPR material will handle higher temperature ranges as well as be oil resistant.



Type EM, E, and N

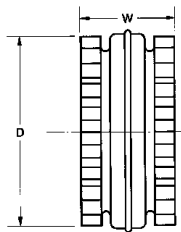

Types EM — E — N

Type EM, E, and N sleeves are of two piece molded construction with Retaining Ring. They are available in ThermoPlastic Rubber (Type TPR), EPDM (Type E), or Neoprene (Type N). These can be used with any type flanges within a given size range.



Type H

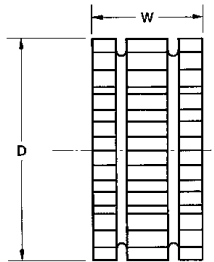

Type HS

Types H & HS

Martin H & HS sleeves are molded Hytrel for higher torque loading than standard EM sleeves. H & HS sleeves cannot be used with style J and B flanges. Hytrel sleeves are not a direct replacement for TPR, EPDM, or Neoprene sleeves.

Dimensions (Inches)

Coupling Size	JEM — JEMS Sleeves			EM - E - N Sleeves			H & HS Sleeves Hytrel•		
	D	W	Wt. (lb.)	D	W	Wt. (lb.)	D	W	Wt. (lb.)
3	1 $\frac{1}{8}$	1	.06	—	—	—	—	—	—
4	2 $\frac{1}{8}$	1 $\frac{1}{4}$.10	2 $\frac{1}{8}$	1 $\frac{1}{4}$.11	—	—	—
5	2 $\frac{5}{8}$	1 $\frac{3}{8}$.20	2 $\frac{5}{8}$	1 $\frac{3}{8}$.25	—	—	—
6	3 $\frac{1}{8}$	1 $\frac{1}{2}$.40	3 $\frac{1}{8}$	1 $\frac{1}{2}$.49	3 $\frac{1}{8}$	1 $\frac{1}{2}$.44
7	4 $\frac{1}{32}$	2 $\frac{1}{8}$.62	4 $\frac{1}{32}$	2 $\frac{1}{8}$.77	4 $\frac{1}{32}$	2 $\frac{1}{8}$.69
8	5 $\frac{1}{8}$	2 $\frac{1}{2}$	1.13	5 $\frac{1}{8}$	2 $\frac{1}{2}$	1.4	5 $\frac{1}{8}$	2 $\frac{1}{2}$	1.4
9	6	3	1.46	6	3	2.0	6	3	1.8
10	7 $\frac{1}{8}$	3 $\frac{1}{8}$	2.32	7 $\frac{1}{8}$	3 $\frac{1}{8}$	3.2	7 $\frac{1}{8}$	3 $\frac{1}{8}$	2.9
11	—	—	—	8 $\frac{3}{8}$	4	5.1	8 $\frac{3}{8}$	4	4.5
12	—	—	—	9 $\frac{3}{8}$	4 $\frac{1}{8}$	8.1	9 $\frac{3}{8}$	4 $\frac{1}{8}$	7.3
13	—	—	—	11 $\frac{3}{8}$	5 $\frac{1}{2}$	13.0	11 $\frac{3}{8}$	5 $\frac{1}{2}$	11.8
14	—	—	—	13 $\frac{3}{32}$	6 $\frac{1}{2}$	21.1	13 $\frac{3}{32}$	6 $\frac{1}{2}$	19.3
16	—	—	—	17 $\frac{29}{32}$	8 $\frac{3}{4}$	45.3	—	—	—

• 13 & 14 Hytrel available with HS sleeves only.

QUADRA-FLEX® Type J Flanges

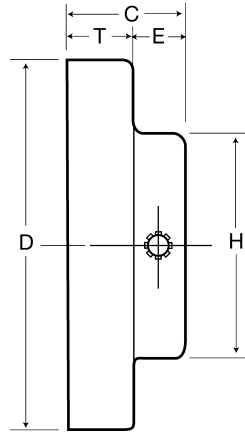

QUADRA-FLEX® Type J Flanges

Martin Type J Flanges are supplied bored to size with standard keyway and two setscrews to slip fit on standard shafting.

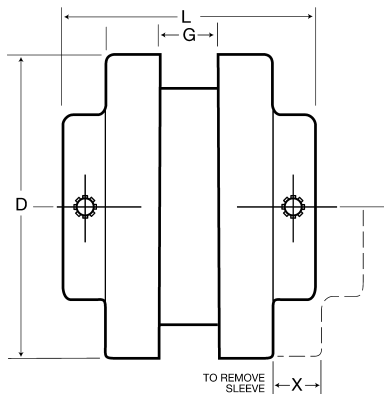

Type J Flanges use the *Martin* JEM 1 Piece, the *Martin* JEMS 1 piece split and the *Martin* EM 2 piece split sleeves.

(Note: Hytrel sleeves are not intended for use with this type of flange.)

Dimensions (Inches)

Coupling Size	Dimensions								Weight (lbs.)★	Finished Bore Sizes* (Inches)		Max. Bore	Millimeters
	C	D	E	G	H	L	T	X					
3J	1 ³ / ₁₆	2.062	7 ¹ / ₁₆	3 ¹ / ₈	1 ¹ / ₄	2	3 ¹ / ₈	9 ¹ / ₁₆	.26	3 ¹ / ₈ ** - 1 ¹ / ₂ - 5 ¹ / ₈ - 3 ¹ / ₄		3 ¹ / ₈	— — —
	1 ³ / ₁₆	2.062	7 ¹ / ₁₆	3 ¹ / ₈	1 ¹ / ₂	2	3 ¹ / ₈	9 ¹ / ₁₆	.26	7 ¹ / ₈		7 ¹ / ₈	— — —
4J	7 ¹ / ₈	2.460	7 ¹ / ₁₆	3 ¹ / ₈	1 ¹ / ₈	2 ¹ / ₈	7 ¹ / ₁₆	3 ¹ / ₄	.47	1 ¹ / ₂ - 5 ¹ / ₈ - 3 ¹ / ₄ - 7 ¹ / ₈ - 1 ¹ / ₂ - 1		1	15 20 25
5J	1 ¹ / ₁₆	3.250	1 ⁵ / ₃₂	3 ¹ / ₄	1 ¹ / ₈	2 ¹ / ₈	1 ⁹ / ₃₂	3 ³ / ₃₂	.86	1 ¹ / ₂ - 5 ¹ / ₈ - 3 ¹ / ₄ - 7 ¹ / ₈ - 1 ¹ / ₂ - 1 - 1 ¹ / ₈		1 ¹ / ₈	— — —
6J	1 ¹ / ₃₂	4.000	1 ⁹ / ₃₂	7 ¹ / ₈	1 ¹ / ₁₆	3 ¹ / ₁₆	5 ¹ / ₈	1 ¹ / ₃₂	1.73	5 ¹ / ₈ - 3 ¹ / ₄ - 7 ¹ / ₈ - 1 ¹ / ₁₆ - 1		—	— — —
	1 ¹ / ₃₂	4.000	1 ⁹ / ₃₂	7 ¹ / ₈	2 ¹ / ₈	3 ³ / ₁₆	5 ¹ / ₈	1 ¹ / ₃₂	1.70	1 ¹ / ₂ - 1 ¹ / ₁₆ - 1 ¹ / ₄ - 1 ¹ / ₈		1 ¹ / ₈	— — —

* Approximate weight for each flange.
 ** 3/8" Bore has no Keyway
 • J flanges can be rebored if necessary.

Type S Flanges

QUADRA-FLEX® Type S Couplings (Bored to Size)

Type S flexible coupling flanges are bored to size to fit on any standard shaft. They are produced from high strength cast iron. Units are easy to install and remove and are stocked in a wide range of bore sizes as shown on the next page.

COUPLINGS

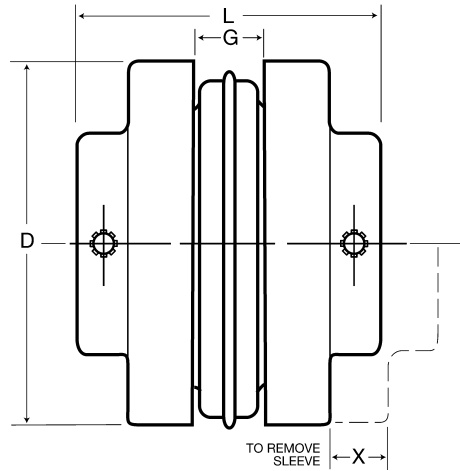

Coupling Size	Flange Diameter (D)	Bore (Inches)			Hub (Inches)			G	L	T	X	Weight (Lbs.)*
		Stock	Rec. Max. ★	Rec. Max. ★★	Hub Diameter (H)	Length Thru (C)	Hub Proj. (E)					
5S	3.250	1/2	1 1/16	1 1/4	1 1/2	1 1/8	2 3/4	3/8	2 1/16	1 1/32	3/32	1.0
6S	4.000	5/8	1 1/16	1 1/2	2 1/2	1 1/8	1 1/2	7/8	3 1/2	3/4	1 1/32	2.1
	4.000	5/8	—	1 1/8	2 1/2	1 1/16	1 1/16	7/8	4	3/4	1 1/32	2.1
7S	4.625	5/8	1 1/8	1 1/8	2 1/16	1 27/32	1 1/16	1	3 1/16	2 3/32	1 1/16	2.7
8S	5.450	3/4	1 1/16	2 1/4	3 1/4	2 29/32	3/4	1 1/8	4 1/16	2 3/32	1 1/2	4.5
	5.450	3/4	—	2 1/8	3 1/4	1 15/16	1 1/2	1 1/8	5	2 3/32	1 1/2	4.5
9S	6.350	7/8	2 1/8	2 1/2	3 3/8	2 13/32	2 3/32	1 1/16	5 1/16	1 1/32	1 1/4	6.5
	6.350	7/8	—	2 1/8	4 1/8	2 29/32	1 1/4	1 1/16	6	1 1/32	1 1/4	6.5
10S	7.500	1 1/8	2 3/4	3 3/8	4 3/8	2 29/32	1 1/16	1 1/8	5 1/16	1 1/32	2	11.3
	7.500	1 1/8	—	3 1/8	4 3/8	2 1/16	1 1/32	1 1/8	7	1 1/32	2	11.3
11S	8.625	1 1/4	3 3/8	3 3/8	5 1/4	3 1/16	1 1/8	1 1/8	7 1/8	1 1/2	2 1/8	17.6
	8.625	1 1/4	—	3 1/8	5 1/8	3 1/16	1 1/16	1 1/8	8	1 1/2	2 1/8	17.6
12S	10.000	1 1/2	3 3/4	3 3/16	5 3/4	4	1 3/32	2 1/16	8 1/4	1 1/16	2 1/16	27.2
13S	11.750	2	4 1/2	—	6 3/4	4 3/8	1 1/16	2 1/16	9 1/4	1 3/32	3 1/16	45.6
14S	13.875	2	5	—	7 1/2	4 1/2	1 1/16	3 1/4	9 3/8	2 1/4	3 1/2	70.0
16S	18.875	2	5 1/2	6	8	6	2	4 3/4	14 1/4	2 3/4	4 1/4	126.0

★ Recommended max. bore with standard keyway.

★★ Recommended max. bore with shallow keyway. See chart on page C-18 for recommended keyway size.

• Approximate weight for each flange.

Keyseat Dimensions

COUPLINGS

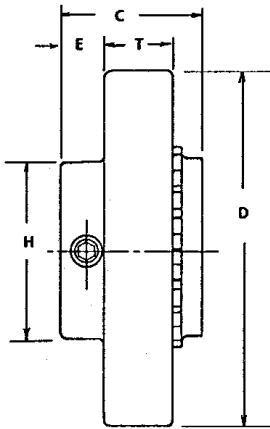

Standard Keyway Dimensions

Shaft Diameter	Width	Depth
1/2-3/8	1/8	1/16
3/8-1/2	3/16	3/32
1/2-1 1/4	1/4	1/8
1 1/8-1 3/4	5/16	5/64
1 1/2-2 1/4	3/8	3/16
1 3/8-2 3/4	1/2	1/4
2 1/8-2 3/4	5/8	5/16
2 1/2-3 1/4	3/4	3/8
3 1/8-3 3/4	7/8	7/16
3 3/8-4 1/2	1	1/2
4 1/8-5 1/2	1 1/4	5/8
5 1/8-6 1/2	1 1/2	3/4

Bore Tolerances for Types J and S Flanges, SC Hubs

Bore (Inch)	Tolerance (Inch)
UP to 1	+0.0000 to +.0010
1 1/8 to 2 1/8	+0.0000 to +.0015
2 3/8 to 2 7/8	+0.0000 to +.0020
2 11/16 to 3 11/16	+0.0000 to +.0025
3 1/8 to 4 1/8	+0.0000 to +.0030
4 13/16 to 6	+0.0000 to +.0035

These bores provide a slip fit.

Shallow Keyseat Dimensions

Coupling Size	Hub Dia. (H)	Length Thru (C)	Shallow Keyseat Dimensions								
			Bore	Keyway	Key	Bore	Keyway	Key	Bore	Keyway	Key
6S	2 1/2	1 1/8	1 5/8	3/8 x 1/4	3/8 x 5/16 x 1 1/4	1 3/4	5/8 x 1/8	3/8 x 1/4 x 1 1/4	1 7/8	1/2 x 1/16	1/2 x 5/16 x 1 1/2
	2 3/16	1 1/16									
7S	2 3/16	1 21/32	1 7/8	1/2 x 1/8	1/2 x 3/8 x 1 13/16						
8S	3 1/4	2 1/8	2 1/8	1/2 x 3/16	1/2 x 7/16 x 2 1/8	2 3/8	5/8 x 1/8	5/8 x 7/16 x 1 15/16			
8S	3 1/4	1 15/16	2 1/8	1/2 x 3/16	1/2 x 7/16 x 2 1/8	2 3/8	5/8 x 1/8	5/8 x 7/16 x 1 15/16	2 7/8	3/4 x 1/8	3/4 x 1/2 x 2 1/8
	3 1/2	2 1/2									
9S	3 3/4	2 1/2	2 1/2	5/8 x 3/16	5/8 x 3/8 x 2 1/2	2 7/8	3/4 x 1/8	3/4 x 1/2 x 2 1/8	3 1/8	7/8 x 3/16	7/8 x 3/8 x 2 11/16
	4 1/4	2 3/4									
10S	4 1/4	2 1/2	2 7/8	3/4 x 1/4	3/4 x 3/8 x 2 11/16	3 3/8	7/8 x 3/16	7/8 x 3/8 x 2 11/16	3 7/8	7/8 x 3/8	7/8 x 3/4 x 2 11/16
	4 3/4	2 11/16									
11S	3 3/4	3 1/8	3 7/8	1 x 1/4	1 x 3/4 x 3	3 7/8	1 x 3/4	1 x 3/4 x 3	4 1/8	1 x 1/4	1 x 1/4 x 3
	4 1/4	3 1/8									
	5 1/4	3 1/8									
	5 3/4	3 1/8									
12S	3 3/4	4	3 15/16	1 x 1/4	1 x 3/4 x 3 15/16	4 1/8	1 x 3/4	1 x 3/4 x 3 15/16	4 3/8	1 x 3/4	1 x 3/4 x 3 15/16
	4 1/4	4									
	5 1/4	4									

Type B Bushed QUADRA-FLEX®

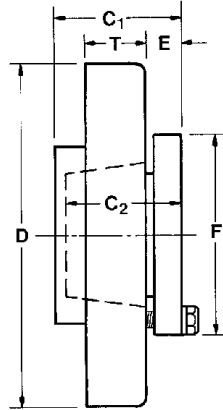

Flanges

Type B flanges are made of high quality cast iron. The same high strength cast iron used in the Type S and SC QUADRA-FLEX flanges. Type B is designed to accommodate *Martin* QD bushings for easy installation and removal. Type B flanges are not intended for use with Hyrel sleeves.

Coupling Size	Bushing Required	Dimensions									Max. Bore★	Weight Lbs.†	
		C1	C2	D	E	F	G	L	T	X		Flange	Bushing
6B	JA	1 ¹ / ₂	1	4.000	7 ¹ / ₁₆	2	7 ¹ / ₁₆	3 ³ / ₁₆	2 ⁵ / ₃₂	1 ¹ / ₂	1 ¹ / ₁₆	1.7	.9
7B	JA	1 ¹ / ₂	1	4.625	7 ¹ / ₁₆	2	1	3 ³ / ₁₆	2 ⁵ / ₃₂	1 ¹ / ₁₆	1 ¹ / ₁₆	2.0	1.0
8B	SH	1 ⁷ / ₃₂	1 ¹ / ₄	5.450	1 ¹ / ₂	2 ¹ / ₁₆	1 ¹ / ₁₆	3 ³ / ₁₆	2 ⁵ / ₃₂	1 ¹ / ₂	1 ¹ / ₁₆	3.1	1.0
9B	SD	2 ³ / ₁₆	1 ¹ / ₁₆	6.350	7 ¹ / ₁₆	3 ³ / ₁₆	1 ¹ / ₁₆	4 ¹ / ₁₆	1 ¹ / ₃₂	1 ¹ / ₄	1 ¹ / ₁₆	4.9	1.5
10B	SK	1 ⁷ / ₃₂	1 ¹ / ₈	7.500	5 ¹ / ₈	3 ³ / ₈	1 ¹ / ₈	5 ¹ / ₁₆	1 ¹ / ₃₂	2	2 ¹ / ₂	7.0	2.0
11B	SF	2 ¹ / ₈	2	8.625	5 ¹ / ₈	4 ¹ / ₈	1 ¹ / ₈	6 ¹ / ₁₆	1 ¹ / ₂	2 ¹ / ₂	2 ¹ / ₂	11.8	3.0
12B	E	2 ¹ / ₁₆	2 ¹ / ₈	10.000	7 ¹ / ₈	6	2 ¹ / ₁₆	7 ¹ / ₁₆	1 ¹ / ₁₆	2 ¹ / ₁₆	3 ¹ / ₁₆	17.2	10.0
13B	F	3 ¹ / ₁₆	3 ¹ / ₈	11.750	1	6 ¹ / ₈	2 ¹ / ₁₆	8 ¹ / ₁₆	1 ³ / ₃₂	3	3 ¹ / ₁₆	30.5	11.5
14B	F	3 ¹ / ₁₆	3 ¹ / ₈	13.875	1	6 ¹ / ₈	3 ¹ / ₄	9 ¹ / ₁₆	2 ¹ / ₄	3 ¹ / ₂	3 ¹ / ₁₆	51.0	11.5
16B	J	4 ¹ / ₈	4 ¹ / ₂	18.875	1 ³ / ₁₆	7 ¹ / ₄	4 ¹ / ₈	12 ¹ / ₂	2 ¹ / ₄	4 ¹ / ₄	4 ¹ / ₂	120.0	18.0

★ Maximum bore with keyseat.

† Approximate weight for each flange.

QD Bushing Keyway Dimensions

Bushing	Bores	Keyseat
JA	1/2 - 1	STANDARD
	1 ¹ / ₁₆ - 1 ¹ / ₈	1/2 x 1/16
	1 ¹ / ₈	1/2 x 1/16
	1 ¹ / ₄	NO K.S.
SH	1/2 - 1 ¹ / ₈	STANDARD
	1 ¹ / ₁₆ - 1 ¹ / ₈	3/8 x 1/16
	1 ¹ / ₁₆	NO K.S.
SD	1/2 - 1 ¹ / ₁₆	STANDARD
	1 ¹ / ₄	5/8 x 1/8
	1 ¹ / ₈	1/2 x 1/8
	1 ¹ / ₈ - 1 ¹⁵ / ₁₆	1/2 x 1/8
	2	NO K.S.
SK	1/2 - 2 ¹ / ₈	STANDARD
	2 ¹ / ₁₆ - 2 ¹ / ₄	1/2 x 1/8
	2 ¹ / ₁₆ - 2 ¹ / ₂	3/8 x 1/16
	2 ³ / ₁₆ - 2 ¹ / ₂	NO K.S.
SF	1/2 - 2 ¹ / ₄	STANDARD
	2 ¹ / ₁₆ - 2 ¹ / ₂	5/8 x 3/16
	2 ¹ / ₁₆ - 2 ¹ / ₂	3/8 x 1/16
	2 ¹ / ₁₆ - 2 ¹ / ₂	3/8 x 1/16
E	7/8 - 2 ¹ / ₄	STANDARD
	2 ¹ / ₁₆ - 3 ¹ / ₄	1/2 x 1/8
	3 ¹ / ₁₆ - 3 ³ / ₄	1/2 x 1/8
F	3 ¹ / ₈	1/2 x 1/8
	1 - 3 ¹ / ₈	STANDARD
	3 ³ / ₈ - 3 ³ / ₄	3/8 x 3/16
	3 ¹³ / ₁₆ - 3 ¹⁵ / ₁₆	1 x 1/8
J	4	NO K.S.
	1 ¹ / ₄ - 3 ¹ / ₄	STANDARD
	3 ¹ / ₁₆ - 3 ³ / ₁₆	1 x 1/8
	4 - 4 ¹ / ₂	1 x 1/8

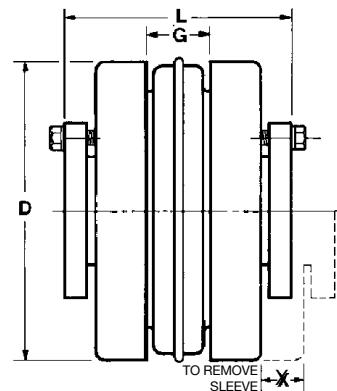

Bushings

Martin QD bushings offer convenient mounting of the flange to the shaft securely without setscrews. They are tapered and are split through both the bushing flange and taper to provide a clamp fit, eliminating wobble, vibration, and fretting corrosion. This is the same bushing used in *Martin* sprockets and sheaves and is readily available.

Type SC Spacer Couplings

COUPLINGS

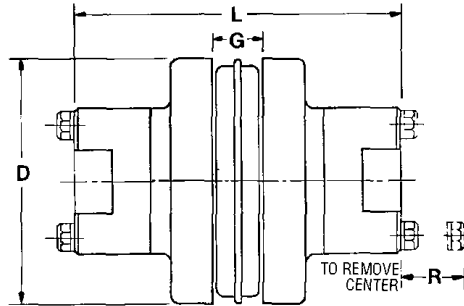

The dimensions for completely assembled QUADRA-FLEX® Type SC Spacer Couplings are shown below. See next page for dimensions of separate components.

Coupling Size	Required Distance Between Shafts	Use Flange Number	Use Hub Number	Max. Bore Standard Keyway	Dimensions				Weight* (Lbs.) [•]
					D	L ²	G	R	
4JSC	3½	4JSC35	4H	1½	2.460	5%	⅝	½	4.7
5SC	3½	5SC35	5H	1½	3.250	5%	¾	⅝	4.1
6SC	3½	6SC35	6H	1½	4.000	5%	⅞	¾	7.1
6SC	4%	6SC44	6H	1½	4.000	6%	⅞	¾	7.9
6SC	5	6SC50	6H	1½	4.000	7%	⅞	¾	8.5
7SC	3½	7SC35	7H	1½	4.625	6%	1	⅝	9.1
7SC	4%	7SC44	7H	1½	4.625	7%	1	⅝	10.1
7SC	5	7SC50	7H	1½	4.625	7%	1	⅝	10.7
8SC	3½	8SC35	8H	1½	5.450	6%	1⅛	⅝	14.7
8SC	3½	8SC35-10	10H★	2%	5.450	8%	1⅛	⅝	22.7
8SC	4%	8SC44	8H	1½	5.450	7%	1⅛	⅝	16.1
8SC	5	8SC50	8H	1½	5.450	8%	1⅛	⅝	15.9
8SC	5	8SC50-10	10H★	2%	5.450	9%	1⅛	⅝	26.5
9SC	3½	9SC35	9H★	2%	6.350	7%	1⅛	⅝	22.0
9SC	4%	9SC44	9H★	2%	6.350	8%	1⅛	⅝	23.4
9SC	5	9SC50	9H★	2%	6.350	8%	1⅛	⅝	24.6
9SC	5	9SC50-11	11H★	2%	6.350	10%	1⅛	⅝	40.2
9SC	7	9SC70-11	11H★	2%	6.350	12%	1⅛	⅝	48.2
9SC	7%	9SC78-11	11H★	2%	6.350	13%	1⅛	⅝	50.8
10SC	4%	10SC48	10H★	2%	7.500	9%	1⅛	⅝	35.4
10SC	5	10SC50	10H★	2%	7.500	9%	1⅛	⅝	38.2
10SC	7	10SC70-13	13H★	3%	7.500	13%	1⅛	⅝	71.8
10SC	7%	10SC78-13	13H★	3%	7.500	14%	1⅛	⅝	75.6
10SC	10	10SC100-13	13H★	3%	7.500	16%	1⅛	⅝	89.0
11SC	4%	11 SC48	11H★	2%	8.625	10%	1⅛	⅝	54.5
11SC	5	11 SC50	11H★	2%	8.625	10%	1⅛	⅝	54.8
11SC	7	11SC70-14	14H	3%	8.625	14%	1⅛	2	85.7
11SC	7%	11SC78-14	14H	3%	8.625	15%	1⅛	2	90.1
11SC	10	11SC100-14	14H	3%	8.625	17%	1⅛	2	102.5
12SC	7	12SC70	12H★	2%	10.000	12%	2⅞	1½	87.7
12SC	7	12SC70-14	14H	3%	10.000	14%	2⅞	2	98.9
12SC	7%	12SC78	12H★	2%	10.000	13%	2⅞	1½	91.5
12SC	7%	12SC78-14	14H	3%	10.000	15%	2⅞	2	103.3
12SC	10	12SC100-14	14H	3%	10.000	17%	2⅞	2	115.5
13SC	7%	13SC78	13H★	3%	11.750	14%	2⅞	1⅝	121.8
14SC	7%	14SC78	14H	3%	13.875	15%	3¼	2	179.4

★ Short (HS) hub also available.

• Approximate weight for completely assembled spacer coupling.

¹ 4JSC35 x 1½ has a shallow keyway.

² "L" dimension and weight will change if one or two short (HS) hubs are used.

NOTE: Refer to page C-23 to order — specify components separately.

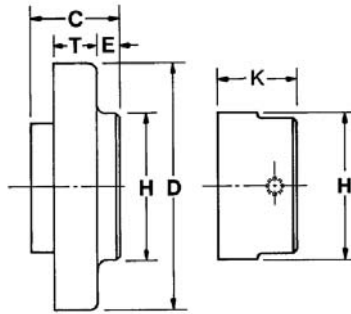

Type SC Flanges and Hubs

Tables below provide dimensional information for QUADRA-FLEX® Flanges and Hubs used for Spacer Couplings. Assembled dimensions are listed on opposite page. Any of the sleeves shown on page C-14 can be used.

Coupling Size	Flange Number	For Distance Between Shafts★	For Hub	Dimensions					Weight (Lbs.)•
				D	E	H	C	T	
4JSC	4SC35	3½	4H	2.460	⅞	2	⅞	⅞	1.2
5SC	5SC35	3½	5H	3.250	5⁄64	2	1 1⁄16	19⁄32	1.2
6SC	6SC35	3½	6H	4.000	19⁄32	2½	1⅝	29⁄32	2.0
	6SC44	4%	6H	4.000	1½	2½	2⅞	29⁄32	2.4
	6SC50	5	6H	4.000	1 1⁄32	2½	2⅝	29⁄32	2.7
7SC	7SC35	3½	7H	4.625	15⁄32	2 13⁄16	1⅝	25⁄32	2.3
	7SC44	4%	7H	4.625	29⁄32	2 13⁄16	2⅞	29⁄32	2.8
	7SC50	5	7H	4.625	1½	2 13⁄16	2⅝	25⁄32	3.1
8SC	8SC35	3½	8H	5.450	⅝	3¼	1⅝	29⁄32	3.5
	8SC35-10	3½	10H-10HS	5.450	⅝	4%	1⅝	29⁄32	3.4
	8SC44	4%	8H	5.450	29⁄32	3 3⁄4	2⅞	29⁄32	4.2
	8SC50	5	8H	5.450	1½	3¼	2⅝	29⁄32	4.6
	8SC50-10	5	10H-10HS	5.450	1½	4%	2⅝	29⁄32	5.3
9SC	9SC35	3½	9H-9HS	6.350	⅞	3%	1 1⁄16	1½	5.1
	9SC44	4%	9H-9HS	6.350	⅞	3%	2⅞	1½	5.8
	9SC50	5	9H-9HS	6.350	¾	3%	2⅝	1½	6.4
	9SC50-11	5	11H-11HS	6.350	¾	5%	2⅝	1½	6.9
	9SC70-11	7	11H-11HS	6.350	1¾	5%	3⅝	1½	10.9
9SC78-11	7%	11H-11HS	6.350	2½	5%	3%	1½	12.1	
10SC	10SC48	4%	10H-10HS	7.500	1 1⁄32	4%	2¼	1½	9.8
	10SC50	5	10H-10HS	7.500	15⁄32	4%	2⅝	1½	10.1
	10SC70-13	7	13H-13HS	7.500	1 19⁄32	6%	3%	1½	14.5
	10SC78-13	7%	13H-13HS	7.500	1 29⁄32	6%	3¼	1½	16.3
	10SC100-13	10	13H-13HS	7.500	2 29⁄32	6%	4%	1½	22.5
11SC	11SC48	4%	11H-11HS	8.625	½	5%	1½	1½	12.5
	11SC50	5	11H-11HS	8.625	⅞	5%	1⅞	1½	12.7
	11SC70-14	7	14H	8.625	1 1⁄16	6%	2 1⁄16	1½	16.1
	11SC78-14	7%	14H	8.625	1 1⁄16	6%	2 15⁄16	1½	18.3
	11SC100-14	10	14H	8.625	2 9⁄16	6%	4 1⁄16	1½	24.5
12SC	12SC70	7	12H-12HS	10.000	2 1⁄32	5%	2 15⁄32	1 11⁄16	23.2
	12SC70-14	7	14H	10.000	2 1⁄32	6%	2 19⁄32	1 11⁄16	21.2
	12SC78	7%	12H-12HS	10.000	1½	5%	2 27⁄32	1 11⁄16	25.1
	12SC78-14	7%	14H	10.000	1½	6%	2 27⁄32	1 11⁄16	23.4
	12SC100-14	10	14H	10.000	2 5⁄32	6%	3 3⁄32	1 11⁄16	29.5
13SC	13SC78	7%	13H-13HS	11.750	⅞	6%	3¼	1 31⁄32	38.4
14SC	14SC78	7%	14H	13.875	½	6%	2 29⁄32	2¼	55.0

★ Flanges can be mixed to form different Between-Shaft Dimensions. See chart on page 23.
 • Approximate weight for each flange.

SC Spacer Hub Bores

COUPLINGS

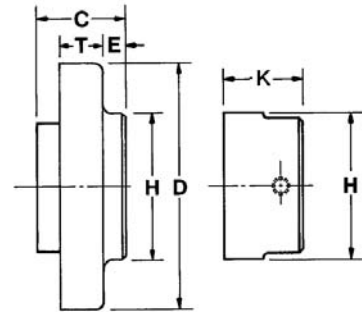
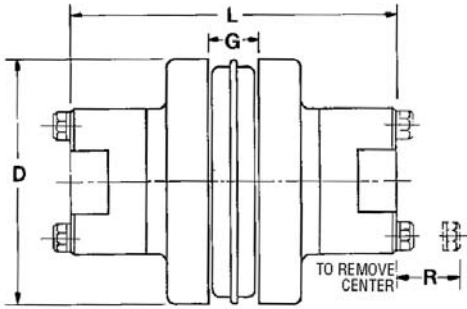

Coupling Size	Hub Number	Max. Bore	Stock Bores		Dimensions			Weight (Lbs.)•
			Plain Bore	Bore with Standard Keyway and Setscrew	K	H	Cap Screws Furnished	
4JSC	4H	1 1/8	1/2	5/8 - 7/8 - 1 - 1 1/8★	1 1/8	2	4 - 10x2	1.1
5SC	5H	1 1/8	1/2	5/8 - 3/4 - 7/8 - 1 - 1 1/8	1 3/16	2	4 - 10x1 1/2	.7
6SC	6H	1 1/8	5/8	3/4 - 7/8 - 1 - 1 1/8 - 1 1/4 - 1 1/2	1 1/16	2 1/2	4 - 1/4x1 1/4	1.3
7SC	7H	1 1/8	3/4	7/8 - 1 - 1 1/8 - 1 1/4 - 1 1/2 - 1 3/4	1 1/8	2 5/8	4 - 1/4x1 1/4	1.9
8SC	8H	1 1/8	3/4	7/8 - 1 - 1 1/8 - 1 1/4 - 1 1/2 - 1 3/4 - 1 1/2 - 1 3/4	1 3/8	3 1/4	4 - 5/8x2 1/4	3.2
9SC	9H	2 1/8	7/8	1 - 1 1/8 - 1 1/4 - 1 1/2 - 1 3/4 - 1 1/2 - 1 3/4 - 2 1/8	1 3/8	3 3/8	4 - 3/4x2 1/4	4.4
	9HS	1 1/2	1 1/8	1 1/8	3 3/8	4 - 3/4x2 1/4	3.7
10SC	10H	2 1/8	1 1/8	1 1/8 - 1 1/4 - 2 1/8 - 2 1/4	2 1/8	4 3/8	4 - 7/8x3	7.3
	10HS	1 1/8	1 1/8	1 3/8	4 3/8	4 - 7/8x2 1/2	5.5
11SC	11H	2 1/8	1 1/8	1 1/8 - 2 1/8 - 2 1/4 - 2 1/2	2 3/8	5 1/4	4 - 1 1/2x3 1/2	12.2
	11HS	1 1/8	1 1/8 - 1 1/4	1 3/8	5 1/4	4 - 1 1/2x2 1/4	9.3
12SC	12H	2 1/8	1 1/8	1 1/8 - 2 1/8 - 2 1/4 - 2 1/2	2 3/8	5 3/8	4 - 1 1/2x4	16.6
	12HS	2 1/8	2 1/8	2 3/8	5 3/8	4 - 1 1/2x3 1/2	14.1
13SC	13H	3 1/8	2 1/8 - 2 1/4 - 3 1/8	3 1/8	6 3/8	4 - 1 1/2x4 1/2	19.9
	13HS	2 1/8	2 1/8 - 2 1/4	2 3/8	6 3/8	4 - 1 1/2x3 1/2	16.0
14SC	14H	3 1/8	2 1/8 - 2 1/4 - 3 1/8 - 3 1/4	3 7/8	6 3/8	4 - 1 1/2x5	24.2

★ 4JSC x 1 1/8 has a shallow keyseat.
• Approximate weight for each hub.

QUADRA-FLEX® Between-Shaft Spacings

Spacer couplings are available with the most popular between shaft dimensions. Spacings other than standard can be achieved by mixing flanges. The “Standard” column provides spacings using identical

flanges; the “Combination” column provides spacings with mixed flanges; the column headed “Semi-Spacer” uses one flange that is not made for spacer coupling and therefore does not have a detachable hub.

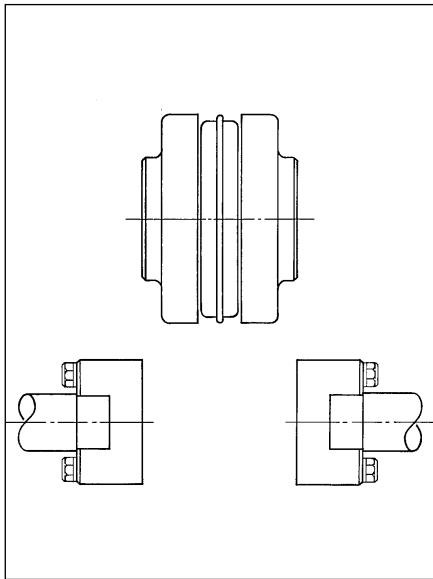

Standard

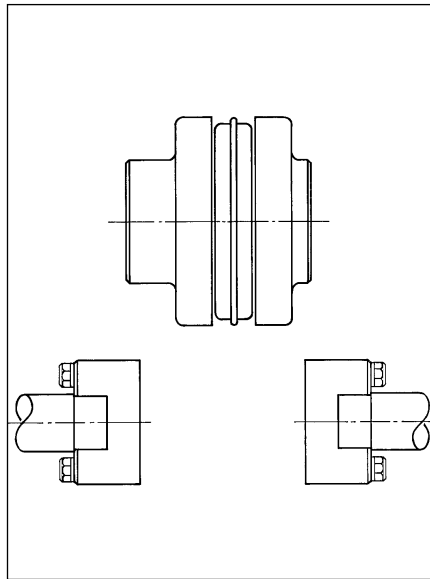

Combination

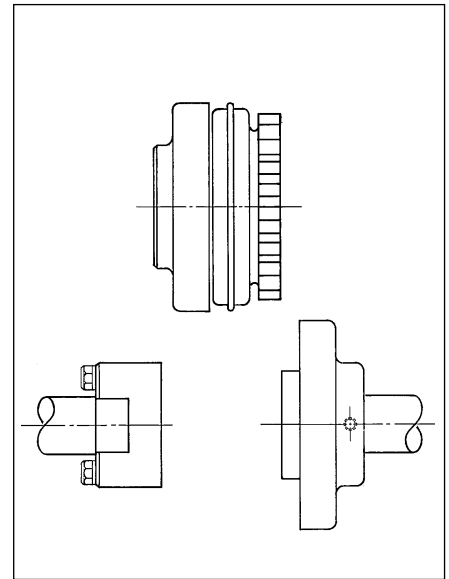

Semi-Spacer

Standard	
Spacing	Use Flanges★
3½	2 - () SC35
4½	2 - () SC44
5	2 - () SC50
7	2 - () SC70
7½	2 - () SC78
10	2 - () SC100

Combination	
Spacing	Use Flanges★
3⅞	SC35 & SC44
4¼	SC35 & SC50
4⅞	SC44 & SC50
5¼	SC35 & SC70
5⅞	SC35 & SC78
5⅞	SC44 & SC70
6	SC50 & SC70
6⅞	SC44 & SC78
6⅞	SC50 & SC78
6⅞	SC35 & SC100★★
7⅞	SC44 & SC100★★
7⅞	SC70 & SC78
7⅞	SC50 & SC100
8¼	SC70 & SC100
8¼	SC78 & SC100

Semi-Spacer	
Spacing	Use Flanges★
1⅞	S & SC35
2⅞	S & SC44
2⅞	S & SC50
3⅞	S & SC70
4	S & SC78
5⅞	S & SC100

★ Check individual coupling size for flange availability.

★★ Non-Stock

NOTE: Other combinations available — consult factory.

Installation Instructions

COUPLINGS

Martin QUADRA-FLEX® flanges (hubs) and elastomeric elements (sleeves) come in a wide range of sizes and types. First, determine the size and type of coupling components required. Remove all components from their boxes and loosely assemble the coupling. **Do not install the wire ring on the two piece sleeves at this time.** Check maximum RPM values in table against operating speeds.

Martin EM sleeves are rated the same as other EPDM and Neoprene sleeves, and may be used interchangeably; however, Hytrel sleeves are rated at different values and may not be interchanged with *Martin* EM sleeves, or the EPDM and Neoprene sleeves. Check horsepower and torque ratings when selecting Hytrel sleeves.



Step 1. Make sure the motor driving the part or components is locked out electrically in such a manner that it cannot be started by anyone, however remote from the area. The same type of lockout procedure applies to any other driving device which may be used. Failure to follow these instructions may result in personal injury or property damage.

Step 2. Prepare shafts for coupling installation. Inspect all coupling components and remove any protective coating or lubricants from bores, mating surfaces, and fasteners.

Step 3. Slide one coupling flange onto each prepared shaft using key stock where required. With the QD Type B flange, it may be necessary to expand the QD bushing bore for ease of installation.

Step 4. Position the flange on the shafts to achieve the approximate “Y” dimension (distance between flanges) shown in table. It is best to have equal shaft length into each flange. Tighten one flange in position, and slide the other flange sufficient distance back to install sleeve. Do not install wire ring on two piece sleeve in its final position at this time, but allow it to hang loosely in groove next to teeth.

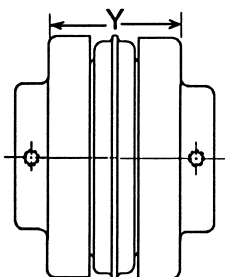

Step 5. Slide loose flange on the shaft until the sleeve has seated completely in teeth of both flanges. Refer to “Y” dimension although not a critical dimension. Secure the flange to shaft and torque set screws and cap screws to correct torque values.



Parallel



Angular

Step 6. Check parallel alignment by placing a straight edge across the two coupling flanges and measure the maximum offset at several points around the periphery of coupling. **Do not** rotate coupling when taking these measurements. Refer to table for maximum allowed offset of parallel alignment. Realign the coupling if necessary.

Step 7. Check angular alignment with a micrometer, vernier, or caliper. Take measurement from outside to outside of flanges at several points around the periphery of coupling. **Do not** rotate coupling when taking these measurements. Determine the difference between maximum and minimum dimensions and check to make sure they do not exceed the angular figure on the table. If a correction is necessary, recheck parallel alignment.

Maximum RPM and Allowable Misalignment (Dimensions in Inches)

Sleeve Size	Max. RPM	Types JEM, EM, E and N			★ Type H & HS		
		Parallel	Angular	Y	Parallel	Angular	Y
3	9200	.010	.035	1.188	—	—	—
4	7600	.010	.043	1.500	—	—	—
5	7600	.015	.056	1.938	—	—	—
6	6000	.015	.070	2.438†	.010	.016	2.500
7	5250	.020	.081	2.563	.012	.020	2.625
8	4500	.020	.094	2.938	.015	.025	3.000
9	3750	.025	.109	3.500	.017	.028	3.563
10	3600	.025	.128	4.053	.020	.032	4.125
11	3600	.032	.151	4.875	.022	.037	4.938
12	2800	.032	.175	5.688	.025	.042	5.750
13	2400	.040	.195	6.688	.030	.050	6.688
14	2200	.045	.242	7.750	.035	.060	7.813
16	1500	.062	.330	10.250	—	—	—

NOTE: Values shown above may apply if the actual torque transmitted is more than ¼ the coupling rating. For lesser torque, reduce the above values by ¼.

★ Type H & HS sleeves should not be used as direct replacements for JEM or EM sleeves.

† Value when using 6J flanges is 2.125.

Step 8. If the coupling employs the two-piece sleeve with wire ring, install ring in center groove of sleeve.

Note: Some force may be required to seat the ring in groove.

Step 9. Install protective guards and/or shields per OSHA and any other additional local or state safety codes as required.

WARNING: Coupling sleeves may be forced from coupling when subjected to a severe shock load or abuse.

Stock Flexible Couplings

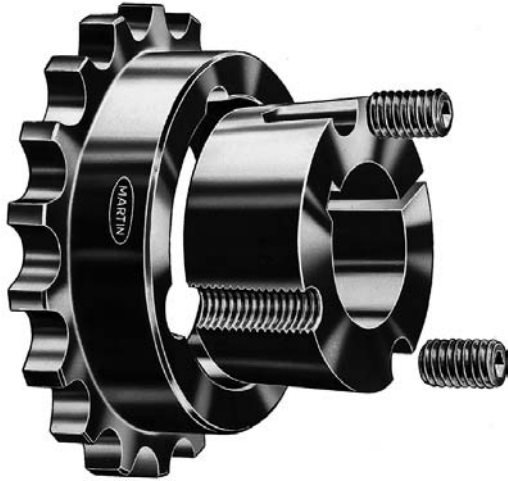

Type TBH



Type TBF

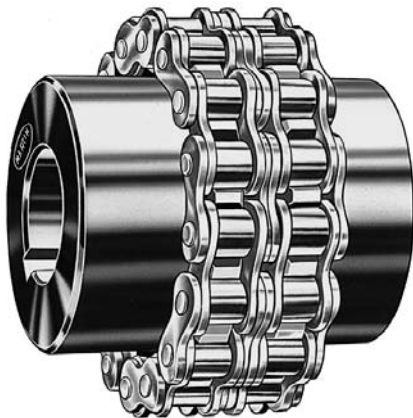

Bored to Size
and Stock Bore



QD



Covers

Stock Flexible Couplings



All *Martin* chain couplings have hardened teeth

Bored to Size Couplings With Finished Bore, Keyway, and Set Screw

Coupling Number	Stock Finishd Bores				A	B	C	L	Coupling O. D.	Weight Lbs.
	Include Standard Keyway and Setscrew									
4012	1/2	5/8	3/4	1	1 1/2	1 1/2	3/2	2 1/2	2 1/2	.4
4016	3/4	1	1 1/8	1 1/4	1 3/4	1 3/4	3/2	2 7/8	3 1/2	.8
5016	1/2	3/4	1	1 1/8	1 1/4	1 1/4	1 1/2	2 1/4	3 3/8	1.6
5018	3/4	1	1 1/8	1 1/4	1 3/4	1 3/4	1 1/2	2 3/4	4 1/8	2.4
6018	1	1 1/4	1 1/2	1 3/4	2 1/4	2 1/4	2 1/4	3 1/2	5	4.8
6020	1 1/4	1 1/2	1 3/4	2 1/8	2 3/4	2 3/4	2 3/4	4 1/8	5 1/2	5.2
6022	1 1/4	1 1/2	1 3/4	2 1/8	2 3/4	2 3/4	2 3/4	4 1/8	5 5/8	7.8
8018	1 1/4	1 1/2	1 3/4	2 1/8	2 3/4	2 3/4	2 3/4	5 1/8	6 1/2	9.5
8020	1 1/2	2 3/8	2 1/2	2 1/4	3 1/4	3 1/4	3 1/4	5 3/8	7 1/8	13.4
10018	1 1/2	2 1/2	2 3/4	2 3/8	3 1/2	3 1/2	3 1/2	6 1/2	8 1/4	18.2
10020	2	3	3 1/2	3 3/8	6 3/8	6 3/8	6 3/8	9 1/2	11 1/2	25.0
12018	3 1/8	3 3/8	4 1/8	4 1/4	8 1/4	8 1/4	8 1/4	10	11 5/8	28.0
12022	4	4 1/2	4 3/4	5 1/4	9 1/4	9 1/4	9 1/4	11 5/8	14 1/2	55.0

CAUTION: All rotating power transmission products are potentially dangerous and must be properly guarded for the speeds and applications for which they were intended.

QD Couplings

Coupling Number	Bushing Used	Max. Bore**	A	B	D	C	L	Coupling O. D.	K†	Weight Lbs.
4016JA	JA	1	2	7/8	1 1/8	3/4	2 3/8	3 1/2	1 1/4	.9
5018SH	SH	1 1/8	2 3/8	1	1 1/2	3/4	3	4 1/8	1 1/4	1.3
6020SK	SK	2	3 1/4	1 1/4	1 3/4	1/2	4 3/8	5 1/2	2 1/4	2.5
8018SF	SF	2 1/8	4 1/8	1 1/2	2	3/4	5 1/8	6 1/2	2 1/4	5.3

** Maximum bore shown is the maximum bore with standard keyway. It is recommended that this maximum not be exceeded in both halves of a coupling.

† Minimum clearance required to remove the coupling half by using the screws as jack screws.

Taper Bushed Couplings Type TBH and TBF

Type TBH Coupling Number	Type TBF Coupling Number	Bushing Data			A	B	C	J*	K†	L	OD	Weight Lbs.
		Bushing Used	Max. Bore	Min. Bore								
4016TBH	4016TBF	1108	1 1/4	1/2	1 3/4	7/8	3/4	3/4	1 1/4	2 1/2	3 1/2	.9
5018TBH	5018TBF	1610	1 1/2	1/2	2 3/8	1	3/4	1 1/8	1 1/2	2 3/4	4 1/8	1.1
6020TBH	6020TBF	2012	2	1/2	3 1/4	1 1/4	1/2	1 5/8	1 3/4	2 5/8	5 1/2	2.7
8020TBH	8020TBF	3020	3	1 1/8	5 1/4	2	3/4	1 3/8	2 1/4	4 3/8	7 1/8	6.1
10020TBH	10020TBF	3535	3 1/2	1 1/4	6 3/8	3 1/2	3/4	2	2 1/2	7 3/8	9 1/2	19.0

* Space needed for (1) tightening bushing with shortened hex key (2) loosening screws for puller to remove hub.

† Minimum clearance required to remove the coupling half by using the screws as jack screws with shortened hex key.

Our Standard Covers Fit These Couplings

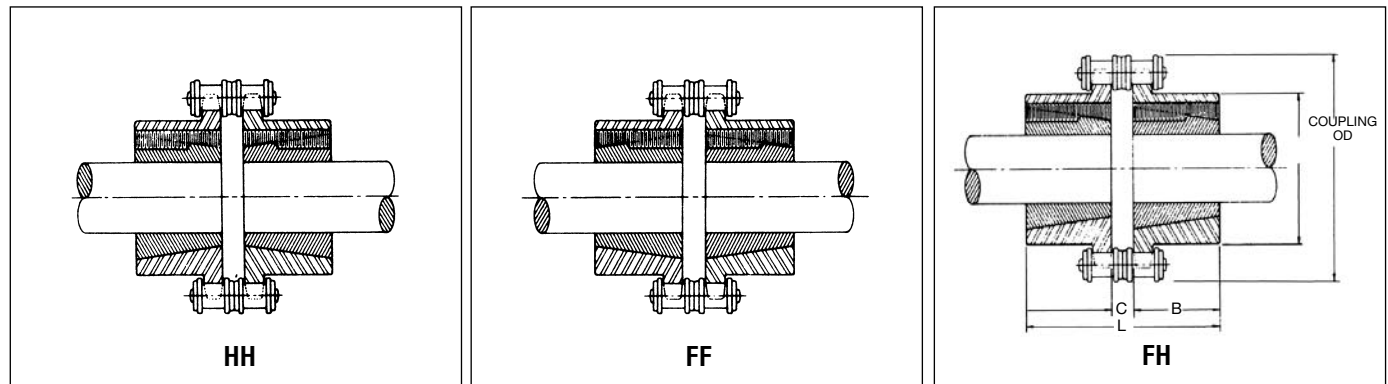

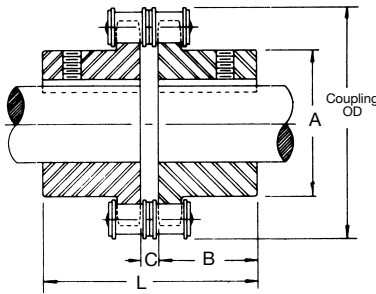

BS Coupling

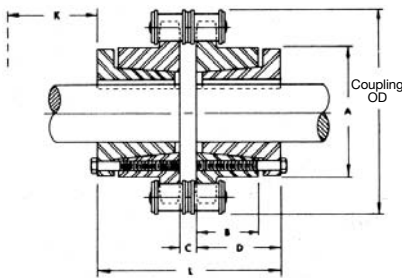

QD Coupling



Type TBF



Type TBH

All *Martin* chain couplings have hardened teeth

Coupling Selection

Roller chain couplings have a torque capacity in excess of the torque normally transmitted by shafting which falls within the coupling bore range. Select the smallest coupling which will accommodate both shafts. For a reversing operation, shock or pulsating loads, or other severe operating conditions, select the next larger coupling size.

A cover should be used to assure maximum service life, particularly if the coupling operates at high speeds or under moist conditions. For proper lubrication, fill the space between the cover and the coupling with soft to medium consistency coupling grease.

Coupling With Plain Bores for Reboring

Coupling Number	Maximum Bore Inches	Minimum Plain Bore Inches	Weight (Lbs.)	Recommended Maximum RPM	Coupling Chain Number	Weight Lbs.
4012	7/8	7/16	.5	5000	4012 CHN	.4
4016	1 1/16	3/8	1.0	5000	4016 CHN	.5
5016	1 1/8	3/4	2.2	4000	5016 CHN	1.2
5018	2	3/4	3.5	3600	5018 CHN	1.3
6018	2 1/8	1	5.0	3000	6018 CHN	2.2
6020	2 1/4	1 1/8	6.5	2500	6020 CHN	2.6
6022	3	1 1/8	9.4	2500	6022 CHN	2.7
8018	3 1/8	1 1/2	11.0	2000	8018 CHN	5.3
8020	3 9/16	1 1/2	16.3	2000	8020 CHN	5.9
10018	3 3/8	1 1/2	20.3	1800	10018 CHN	9.8
10020	4 1/8	1 1/2	31.8	1800	10020 CHN	10.9
12018	4 1/16	2	36.8	1500	12018 CHN	17.3
12022	6 1/8	2	70.0	1200	12022 CHN	21.2

Stock Coupling Covers

Covers Fit Taper Bushed, QD and Stock, and Finished Bore Couplings. Covers allow excellent lubrication, and their use is recommended to obtain maximum coupling life. Covers are of aluminum and are made in halves for easy installation. Synthetic rubber oil seals, which contact the coupling hubs, retain the lubricant and prevent the entry of dirt. Covers are fitted with gaskets between the halves.

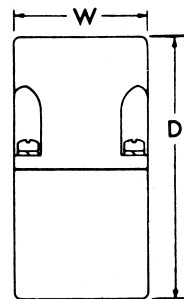

Aluminum
and
Plastic

Cover Cat. No.	Aluminum		Plastic		Wt. Lbs.
	D	W	D	W	
4012COV**	4	2	4	2 5/16	.78
4016COV**	4	2	4	2 7/16	.92
5016COV**	5 1/8	2 1/8	5 1/8	2 5/8	1.30
5018COV**	5 1/8	2 1/8	5 1/8	2 5/8	1.30
6018COV**	6 1/8	2 5/16	6 1/8	3 1/16	2.44
6020COV**	6 1/8	2 5/16	6 1/8	3 1/16	2.44
6022COV*	8 3/8	4	8 3/8	4	4.88
8018COV	8 3/8	4	8 3/8	4	4.88
8020COV	8 3/8	4	8 3/8	4	4.88
10018COV	9 1/8	5 1/16	9 1/8	5 1/16	8.76
10020COV	10 1/8	5 1/8	10 1/8	5 1/8	12.66
12018COV	11 1/8	7 1/8	11 1/8	7 1/8	16.46
12022COV	13 1/8	7 1/16	13 1/8	7 1/16	19.50

* Use 8018 cover — Special Seals Available
 ** Furnished in Plastic unless specified with "AL" Suffix when ordering.

Flexible Jaw Couplings

Martin

COUPLINGS

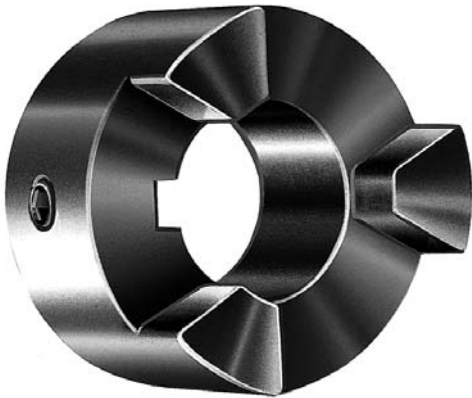

Martin Universal (ML)



Martin Super (MS)

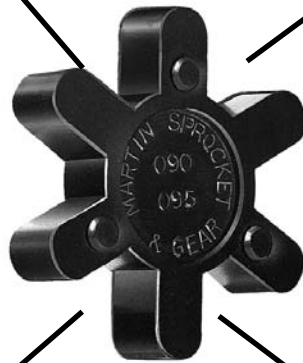

Now *Martin* Offers Two Styles

The *Martin Super* — Higher Horsepower

The *Martin Universal* — Completely Interchangeable

- No Lubrication
- Easy Installation
- No Metal to Metal Contact
- Resistant to oil, dirt, sand, moisture, grease
- Easy inspection of load carrying Spider
- Flexibility of angular or parallel misalignment of shafts by Buna-N Spider member permits smooth "Power Transmission"

Jaw Coupling Selection Procedure

- A. Determine Service Factor by Matching Driven Unit with Prime Mover in Service Factor Guide.
- B. Multiply Service Factor by Driven Unit or Motor H.P. to Obtain Adjusted H.P.
- C. Select Flexible Coupling with Horsepower Capacity Equal to or Greater than Adjusted H.P.

Service Factor Guide	Prime Mover		
	Electric Motor or Steam Turbine	Gasoline or Diesel Engine, 6 or More Cyl.	Gasoline or Diesel Engine, Less Than 6 Cyl.
Driven Unit (Machinery)			
Light: Uniform or steady load never exceeding horsepower rating, infrequent starting. Agitators, Blowers, Conveyors, Evaporators, Fans, Generators, Centrifugal Pumps, Stokers	1.0	1.5	2.0
Moderate: Heavy inertia, moderate shock, frequent starting; peak loads do not exceed 125 per cent average horsepower. Uneven load. Beaters, Rotary Pumps and Compressors, Cranes, Elevators, Mine and Propellor Fans, Generators, Pulp Grinders, Hoists, Kilns, Machine Tools, Mixers, Gear Pumps, Woodworking Machines	1.5	2.0	2.5
Heavy: Heavy shock conditions or frequent reversing. Peak loads do not exceed 150 per cent average horsepower. Uneven load. Reciprocating Pumps and Compressors, Crushers, Freight and Passenger Elevators, Mills (Hammer, Ball, Rolling, Turf, Flour), Vibrating Screens, Winches, Wire Drawing Machines, Punches, Shears	2.0	2.5	3.0



Bore Tolerances:
 $\frac{1}{2} - 1 \frac{3}{4} + .001 - .000$
 $1 \frac{13}{16} - 2 \frac{5}{8} + .0015 - .0000$

Martin ML (Universal Series) — Torque and Horsepower Ratings

Catalog Number	Torque Rating Lb. — In.		Buna-N Horsepower Capacity at Various RPM					Max. Bore	(Each) Weight
	Buna-N	Hytrel®	100	300	1200	1800	3600		
ML035	3.5	—	.006	.02	.07	.10	.20	$\frac{3}{8}$.07
ML050	31.5	94.5	.05	.15	.60	.9	1.8	$\frac{3}{8}$.13
ML070	42	126	.07	.21	.84	1.2	2.5	$\frac{3}{4}$.25
ML075	81	242	.13	.39	1.56	2.3	4.7	$\frac{7}{8}$.44
ML090	140	420	.22	.66	2.64	4.0	7.9	1 $\frac{1}{8}$.69
ML095	189	567	.30	.90	3.6	5.4	10.8	1 $\frac{1}{8}$.84
ML099	290	870	.46	1.4	5.5	8.3	16.6	1 $\frac{3}{8}$	1.19
ML100	416	1248	.66	2.0	7.9	11.9	23.8	1 $\frac{3}{8}$	1.47
ML110	756	2268	1.2	3.6	14.4	21.6	43.2	1 $\frac{5}{8}$	3.20
ML150	1197	3591	1.9	5.7	22.8	34.2	68.4	1 $\frac{7}{8}$	4.50
ML190	1512	4536	2.4	7.2	28.8	43.2	86.4	2 $\frac{1}{8}$	8.25
ML225	2268	6804	3.6	10.8	43.2	64.8	129.6	2 $\frac{5}{8}$	12.00

NOTE: Above H.P. capacities are for Buna-N rubber spider and service factor of one. When Hytrel spider is used multiply capacities by three.

Martin MS (Super Series) — Torque and Horsepower Ratings

Catalog Number	Torque Rating Lb. — In.		Buna-N Horsepower Capacity at Various RPM					Max. Bore	(Each) Weight
	Buna-N	Hytrel®	100	300	1200	1800	3600		
MS050	37.3	112	.06	.18	.71	1.0	2.1	$\frac{3}{8}$.13
MS070	59.4	178	.09	.28	1.1	1.7	3.4	$\frac{3}{8}$.25
MS075	157	471	.25	.75	3.0	4.5	8.9	$\frac{3}{8}$.44
MS090	241	723	.38	1.1	4.6	6.9	13.7	1 $\frac{1}{8}$.69
MS095	241	723	.38	1.1	4.6	6.9	13.7	1 $\frac{1}{8}$.84
MS099	512	1536	.81	2.4	9.7	14.6	29.2	1 $\frac{1}{8}$	1.19
MS100	512	1536	.81	2.4	9.7	14.6	29.2	1 $\frac{1}{8}$	1.47
MS110	1014	3042	1.6	4.8	19.3	28.9	57.8	1 $\frac{3}{8}$	3.20
MS150	1630	4890	2.6	7.7	31.0	46.5	93.0	1 $\frac{5}{8}$	4.50
MS190	2450	7350	3.9	11.6	46.6	69.9	139.7	2 $\frac{1}{8}$	8.25
MS225	2920	8760	4.6	13.9	55.5	83.2	166.5	2 $\frac{5}{8}$	12.00

NOTE: Above H.P. capacities are for Buna-N rubber spider and service factor of one. When Hytrel spider is used multiply capacities by three.

Misalignment Capacities: Angular up to 1°, Parallel up to .015 inches.

Hytrel is a registered trademark of E.I. DuPont & Co.

Stock Jaw Couplings

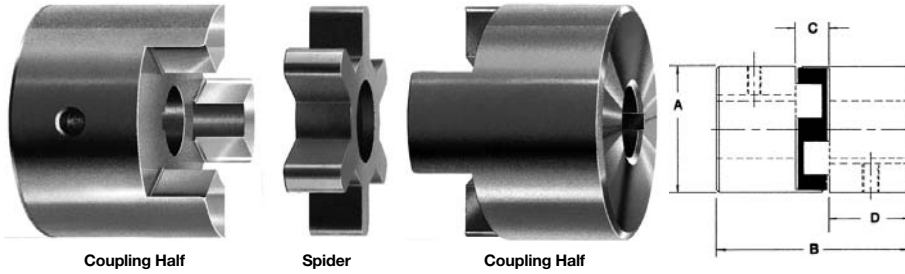

Coupling Half

Spider

Coupling Half

COUPLINGS

Dimensions

Catalog Number	Hub Dia. A	Overall Length B	Distance Betw. Flanges C	Length Thru Bore D	Bore		Weight Lbs.
					Min.	Max.	
ML035	3/8	1 1/16	3/16	1 7/64	3/16	3/8	.07
ML or MS050	1 1/16	1 7/16	3/16	3/4	1/4	3/4	.13
ML or MS070	1 1/8	2	1/2	3/4	1/4	3/4	.25
ML or MS075	1 1/4	2 1/8	1/2	1 1/16	1/4	3/4	.44
ML or MS090	2 1/8	2 1/2	1/2	1 3/16	1/4	1 1/8	.69
ML or MS095	2 1/4	2 1/2	1/2	1	3/16	1 1/8	.84
ML or MS099	2 1/2	2 3/4	3/4	1 1/8	1/2	1 1/4	1.19
ML or MS100	2 3/8	3 1/8	3/4	1 1/4	1/2	1 1/4	1.47
ML or MS110	3 1/8	4 1/8	3/4	1 1/2	1/2	1 1/4	3.20
ML or MS150	3 3/8	4 3/8	1	1 3/4	3/4	1 1/2	4.50
ML or MS190	4 1/8	4 3/4	1	1 15/16	3/4	2 1/8	8.25
ML or MS225	5	5 3/8	1	2 3/16	3/4	2 3/8	12.00

Bore sizes are standard in 1/16" increments from minimum to maximum bore range and have keyway and set screw except as shown below:

- 1/8 through 3/8 Bore — No KW — No SS
- #050 — 7/16 through 5/8 Bore — No KW — 1-SS
- #070, 075, 090, 095 — 7/16 and 1/2 Bore — No KW — 1-SS
- #099, 100, 110 — 1/2 Bore — No KW — No SS
- #150 — 5/8 Bore — No KW — No SS
- #190, 225 — 3/4 Bore — No KW — No SS

NOTE: In each coupling size a min. plain bore is available that can be used to make special bores such as spline, hex, metric, or other shapes or sizes.

For Standard Keyway sizes see *Martin* Catalog, page E-158 and E-159.

Coupling Selection Chart for 60 Hz Nema Motor Frames Based on Buna-N (Rubber) Spider ★†

Shaft Diameter	Nema Frame	Coupling Size	Max. Horsepower Rating @ RPM					
			1140		1725		3450	
			MS	ML	MS	ML	MS	ML
3/8	42	050	1/2	1/2	1	3/4	2	1 1/2
1/2	48	050	1/2	1/2	1	3/4	2	1 1/2
3/4	56,56 H	050	1/2	1/2	1	3/4	2	1 1/2
1	66	070	1	3/4	1 1/2	1	3	2
3/4	56HZ, 143T, 145T 182, 184	075	2	1	3	2	7 1/2	3
		090	3	2	5	3	10	7 1/2
1 1/8	182T, 184T, 213 215	095	3	3	5	5	10	10
		099	7 1/2	5	10	7 1/2	25	15
1 1/4	213T, 215T, 245U, 256U	100	7 1/2	7 1/2	10	10	25	20
1 1/2	254T, 256T, 248U, 286U	110	15	10	25	20	50	40
1 3/4	284T, 286T, 324U, 326U, 326TS	150	30	20	40	30	75	60
		190	40	25	60	40	125	75
2	324T, 326T, 364U, 365U	225	50	40	75	60	150	100
		225	50	40	75	60	150	100

NOTE: Coupling Sizes are based on the rated torque, max. bore and a have a service factor of 1.0.

* When Using Hytrel or Bronze spider multiply above horsepower ratings by 3.

† When using Urethane spider multiply above horsepower ratings by 1.5.

Spiders — Buna-N (Rubber) and Hytrel

Catalog Number		Accommodates Coupling	Net Weight Lbs.	
Buna-N	Hytrel		Buna-N	Hytrel
SRL035	SHL035	ML035	.009	.009
SRL050	SHL050	M 050 — MS 050	.013	.013
SRL070	SHL070	ML070 — MS 070	.017	.017
SRL075	SHL075	ML075 — MS 075	.03	.03
SRL090	SHL090	ML or MS090-095	.04	.04
SRL099	SHL099	ML or MS099-100	.07	.07
SRL110	SHL110	ML110 — MS110	.14	.14
SRL150	SHL150	M150 — MS150	.21	.21
SRL190	SHL190	ML190 — MS190	.27	.27
SRL225	SHL225	ML225 — MS225	.41	.41

Urethane spiders available. Please consult factory.

Spiders — Urethane† and Bronze★

Catalog Number		Accommodates Coupling	Net Weight Lbs.	
Urethane	Bronze★		Urethane	Bronze
SUL035		ML 035	.009	
SUL050		ML050 — MS050	.013	
SUL070		ML070 — MS070	.017	
SUL075		ML075 — MS075	.03	
SUL090		ML or MS 090-095	.04	
SUL099		ML or MS 099-100	.07	
SUL110		ML110 — MS110	.14	
SUL150		ML150 — MS150	.21	
SUL190		ML190 — MS190	.27	
SUL225		ML225 — MS225	.41	

★ Bronze spiders available as Made to Order.



Metric Bore Sizes Available
Consult Factory

Parts List and Engineering Data

Coupling Size	QD Bushing (2 Required Per Coupling)	Steel Flange Assembly (2 Required Per Coupling)		Rubber Element (1 Required Per Coupling)		Max RPM	Horsepower @ 100 RPM (1.0 Factor)	Torque (1.0 Service Factor)		Average Static Torsional Stiffness Coefficient (K)		Approx. WR2** (LB - Ft ²)
		Flange No.	Weight Each	Element No.	Weight			LB - In	LB - Ft	LB - In/DEG	LB - In/RAD	
5	JA	F5JA	3.0	E5	.6	4500	1.03	649	54.1	244	12,850	.08
6	JA	F6JA	4.0	E6	.9	4000	1.80	1134	94.5	414	23,700	.22
7	SH	F7SH	7.0	E7	1.3	3600	3.12	1966	163.8	544	31,200	.40
8	SDS	F8SDS	8.0	E8	1.7	3100	4.68	2950	245.8	876	50,200	.70
9	SK	F9SK	13.0	E9	2.0	2800	6.90	4349	362.4	1088	62,400	1.33
10	SF	F10SF	17.0	E10	2.0	2600	8.33	5250	437.5	1530	87,700	2.10
11	SF	F11SF	18.0	E11	3.0	2300	9.92	6252	521.0	2420	138,700	2.90
12	E	F12E	31.0	E12	3.8	2100	14.40	9076	756.3	4014	217,000	5.80

* See page B5 for QD bushing bore sizes and dimensions.

** Coupling plus QD bushing.

★ Weight in pounds.

Rubber tire element also available in Neoprene.

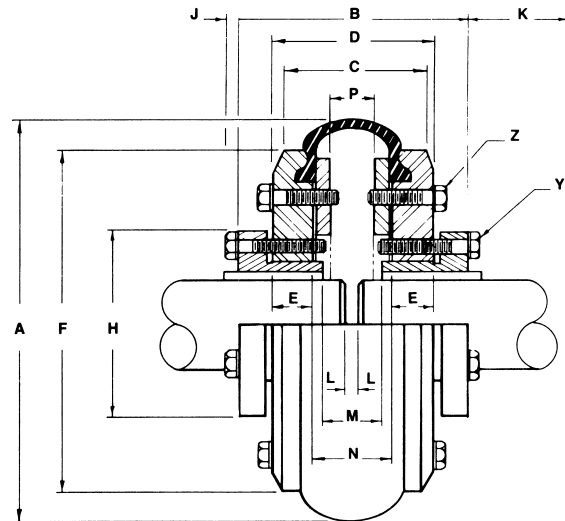

Dimensions

Coupling Size	A	B	C	D	E	F	H	J	K*	L	M	N	P	Z Clamp Ring Bolts			
														Y B.C. Dia.	B.C. Dia.	No. and Size*** Capscrews	Torque In Lbs.
5	5 1/4	3 3/16	2 1/16	2 3/16	5/8	4	2	5/32	1 1/4	..	1 1/16	1 1/16	3/8	1.66	2 3/16	(5) 1/4 - 20x1 1/8	125
6	6 1/2	3 3/16	2 3/16	2 11/16	5/8	4 13/16	2	5/32	1 1/4	..	1 1/16	1 1/16	1/2	1.66	3 3/16	(5) 5/16 - 18x1 1/8	200
7	7 7/8	4 3/16	2 11/16	3 3/16	13/16	5 5/8	2 11/16	7/32	1 1/2	..	1 11/16	1 1/16	3/4	2 1/4	3 3/8	(5) 5/16 - 18x1 1/4	300
8	8 3/4	4 7/16	2 3/8	3 3/8	13/16	6 1/2	3 3/8	1/2	1 1/2	..	1 13/16	1 11/16	7/8	2 11/16	4 1/4	(6) 5/16 - 18x1 1/2	300
9	9 1/2	5 1/16	3 3/16	3 3/8	1 1/8	7 3/8	3 3/8	5/32	2 1/4	..	1 1/8	1 13/16	7/8	3 3/8	5 1/4	(6) 5/8 - 16x1 3/4	400
10	10	5 3/16	3 3/16	4 1/16	1 1/8	8 5/8	4 3/8	3/8	2 3/4	..	1 1/8	1 1/8	1	3 3/8	6	(6) 5/8 - 16x1 3/4	400
11	11	5 3/8	3 3/8	4 3/8	1 1/8	9 1/8	4 3/8	5/8	3 1/4	..	1 3/8	1 3/8	1 1/8	3 3/8	6 1/2	(6) 5/8 - 16x1 3/4	400
12	12 3/4	7 1/4	4	4 3/4	1 1/2	10 1/8	6	3/4	4 1/4	..	1 1/2	1 1/2	3/4	5	7 1/4	(6) 1/2 - 13x2 1/4	900

* Clearance required to remove bushing using pull-up capscrews as jackscrews.

** Shaft ends are normally M or N apart; they may project beyond the bushings. In this case allow space for end float and misalignment.

*** Grade 8.

Dimensions in inches.

Other Sizes Available as Made-to-Order

Martin Flex® flexible couplings smoothly transmit power while compensating for shaft misalignment to 4°, parallel misalignment to 1/8" and end float to 5/16". The two piece flange design provides quick and easy installation and the elastomeric element absorbs shock and torsional vibration through a wide temperature range.

COUPLINGS

Selection Procedure

1. Select the proper service factor from Chart 1.
2. Determine **Design Horsepower** by multiplying the **Service Factor** and the **Drive Horsepower**.
3. Locate the intercept of **Shaft Speed** and **Design Horsepower** from Chart 2.
4. Order per coupling: (2) bushings, (2) flange assemblies, (1) flexible tire element.

Chart 1 Service Factors

Application	Factor	Application	Factor	Application	Factor	Application	Factor
AGITATORS		Pump, Screen Drive, Stacker, Utility Winch	1.5	METAL FORMING MACHINES		Hog	2.0
Paddle or Propeller		DYNAMOMETER	1.0	Draw Bench Carriage,		Roller	1.5
(Vert. or Horiz.), Screw	1.0	ELEVATORS		Main Drive, Extruder,		PUMPS	
BREWING AND DISTILLING		Bucket, Freight	2.0	Wire Drawing, Flattening		Centrifugal	1.0
Bottling Machinery,		EXCITER	1.0	Machine	2.0	Descaling, Gear Type	1.5
Brew Kettle, Cooker		FANS		MILLS (Rotary Type)		Oil Well Pumping (not	
(Cont. Duty), Mash Tub	1.0	Centrifugal	1.0	Ball or Pebble Direct or	2.5	over 150% peak torque)	2.0
Scale Hopper —		Cooling Tower	2.0	on LS Shaft Gear Reducer	2.5	Rotary — other than gear	1.5
Frequent Starting Peaks	1.5	Large (Mine, etc.)	1.5	on HS Shaft Gear Reducer	2.0	Reciprocating —	
CAN FILLING MACHINE	1.0	Light	1.0	Dryer and Cooler	1.5	1 cyl. — single acting	2.5
CAR DUMPER	1.5	Propeller (indoor)	1.5	Rod or Tube Direct or	2.5	1 cyl. — double acting	2.0
CAR PULLER	1.5	FOOD INDUSTRY		on LS Shaft Gear Reducer	2.5	2 cyl. — single acting	2.0
CLARIFIER	1.0	Beet Slicer	1.5	on HS Shaft Gear Reducer	2.0	2 cyl. — double acting	1.5
CLASSIFIER	1.0	Cereal Cooker	1.0	Tumbling Barrel	1.5	3 cyl. — or more	1.5
CLAY-WORKING MACHINES		Dough Mixer,		MIXERS		RUBBER INDUSTRY	
Brick Press, Briquette		Meat Grinder	1.5	Concrete (Continuous or		Banbury Mixer	2.5
Machine, Clay Working		GENERATORS		intermittent), Muller-		Calender	2.0
Machine, Pug Mill	1.5	Even Load	1.0	Simpson type	1.5	Cracker, Mixing Mill,	
COMPRESSORS		Hoist or Railway Service	1.5	OIL INDUSTRY		Plasticator	2.5
Lobe, Rotary	2.0	Welder Load	2.0	Chiller	1.0	Refiner, Sheeter, Tire	
Reciprocating** —		GRIZZLY	2.0	Oil Well Pumping (not		Building Machine	2.0
1 cyl. — single acting	3.5	KILN	2.0	over 150% peak torque)	2.0	Tire and Tube Press Opener	
1 cyl. — double acting	3.0	LAUNDRY MACHINES		Paraffin Filter Press	1.5	(Based on Peak Torque)	1.0
2 cyl. — single acting	3.0	Tumbler, Washer	2.0	PAPER MILLS		Tuber and Strainer	1.5
2 cyl. — double acting	2.5	LINE SHAFTS		Agitator	1.0	Warming Mill	2.0
3 cyl. or more —		Driving Processing		Barking Drum	2.5	Washer	2.5
single acting	2.5	Machinery	1.0	Beater and Pulper	1.5	SCREENS	
3 cyl. or more —		Light	1.0	Bleacher	1.0	Air Washing	1.0
double acting	2.0	LUMBER INDUSTRY		Calender	2.0	Coal and Sand (Rotary)	1.5
CONVEYORS		Band Resaw		Chipper	3.0	Vibrating	2.5
Apron, Assembly, Belt,		Circular Resaw	1.5	Couch, Cylinder, Dryer	1.5		
Chain, Flight, Oven	1.0	Edger, Head Rig,		Felt Stretcher	1.0		
Reciprocating	2.5	Hog, Log Haul	2.0	Fourdrinier	1.5		
Screw	1.0	Planer	1.5	Jordan	2.0		
CRANES AND HOISTS		Rolls Non-Reversing	1.5	Press	2.0		
Main Hoist —		Rolls Reversing	1.5	Pulp Grinder	2.0		
Medium Duty	1.5	Sawdust Conveyor	1.0	Stock Chest	1.5		
Main Hoist —		Slab Conveyor,		Stock Pump			
Heavy Duty	2.0	Sorting Table	1.5	Reciprocating	2.0		
Skip Hoist, Travel Motion,		MACHINE TOOLS		Rotary	1.5		
Trolley Motion, Slope	1.5	Auxiliary	1.0	Suction Roll	2.0		
CRUSHERS		Main Drive, Notching		Winder	1.5		
Cane	2.0	Press, Planer		PARAFFIN FILTER PRESS	1.5		
Gyrator	2.5	(Reversing), Plate Planer,		PRINTING PRESS	1.5		
DREDGES		Punch Press	1.5	PROPELLER (Marine)	1.5		
Cable Reel, Conveyor	1.5	Traverse	1.0	PULVERIZERS			
Cutter Head Drive,				Hammermill — Light Duty	1.5		
Jog Drive	2.5			Hammermill — Heavy Duty	2.0		

The service factors listed are intended only as a general guide for smooth power sources such as electric motors and steam turbines. Add 0.5 to factor for somewhat rougher power sources such as internal combustion engines of four or more cylinders, steam engines and water turbines. Where substantial shock occurs or starting or stopping is frequent as on some "inching" drives and on some reversing drives or where the power source is an internal combustion engine with less than four cylinders — consult factory. Where torsional vibrations occur as in, for example, internal combustion engines or reciprocating compressors or pump applications, check the coupling for possible development of damaging large amplitude vibrations.

** Add 0.5 to factor if without flywheel.

Chart 2 Size Selection

