

**FAG**



## **FAG special spherical roller bearings for vibratory machinery**

**X-life quality**



**SCHAEFFLER GROUP**  
INDUSTRIAL



# Welcome to the Future! Unmatched Engineering Excellence. INA and FAG



## Partner Power

X-life – this is the premium grade from INA and FAG, offering you new opportunities for success. Benefit from the combined expertise of two brands with a worldwide reputation – in every area of application covering automotive, machine building and precision engineering.

In the Schaeffler Group, INA and FAG have brought together their strengths to give a new dimension in quality:

**X-life.**  
**Higher cost-effectiveness.**  
**Higher operational security.**

### What X-life offers:

X-life offers excellent product quality that far exceeds previous standards.

Furthermore, X-life optimises all the parameters that are decisive for a problem-free production cycle. This includes correct fitting and dismantling, maintenance intervals matched to the specific application and the selection of lubricants matched to operating conditions.

A further convincing advantage of X-life is product characteristics that fulfil your specific requirements and offer additional benefits: for example, particularly low-noise, maintenance-friendly or high load capacity system solutions.

### Your X-life advantages at a glance:

- product characteristics far above the norm
- lasting quality assurance and control
- extremely high reliability
- even greater security in planning and systems
- optimum availability
- smooth-running work processes
- reduced energy consumption
- the maximum possible cost-effectiveness
- the maximum possible level of service and support

**Welcome to the Future!**  
**Unmatched Engineering Excellence.**  
**INA and FAG**

**FAG**

**SCHAEFFLER GROUP**  
INDUSTRIAL

# Contents

<b>1</b>	<b>FAG spherical roller bearings for vibratory stresses</b>	<b>2</b>
1.1	Operating conditions for bearings in vibratory machinery	2
1.2	Bearing series and basic designs	2
1.2.1	X-life spherical roller bearings of series 223..-E1	2
1.2.2	Spherical roller bearings of series 223..-A	3
1.2.3	Spherical roller bearings of series 233..-A	3
1.3	Bearings with tapered bore	3
1.4	Bearings with coated bore	3
1.5	Specification T41A(D)	3
1.5.1	Tolerances for bearing bore and outside diameter	3
1.5.2	Radial internal clearance groups, reduction in radial internal clearance of bearings with tapered bore	4
1.6	Permissible radial acceleration	6
1.7	Heat treatment	6
<b>2</b>	<b>Dimensioning of bearings</b>	<b>6</b>
2.1	Two bearing screen with circle throw	6
2.2	Two bearing screen with straight line motion	8
2.3	Eccentric screen	10
2.4	Nomogram for calculation of centrifugal force	11
2.5	Nomogram for calculation of basic load ratings	12
<b>3</b>	<b>Design of bearing arrangements</b>	<b>13</b>
3.1	Two bearing screen with circle throw (grease lubrication)	13
3.2	Two bearing screen with circle throw (oil sump lubrication)	14
3.3	Two bearing screen with circle throw (recirculating oil lubrication)	15
3.4	Two bearing screen with straight line motion (oil splash lubrication)	16
3.5	Four bearing screen (grease lubrication)	17
<b>4</b>	<b>Lubrication of bearings</b>	<b>18</b>
4.1	Grease lubrication	18
4.2	Oil lubrication	18
4.2.1	Oil sump lubrication	19
4.2.2	Recirculating oil lubrication	21
4.3	Recommended lubricants	22
<b>5</b>	<b>Dimension tables for FAG special spherical roller bearings for vibratory machinery</b>	<b>23</b>
5.1	Series 223..-E1-T41A(D)	23
5.2	Series 223..-A-MA-T41A	24

# FAG spherical roller bearings for vibratory stresses

Operating conditions · Bearing series and basic designs

## 1 FAG spherical roller bearings for vibratory stresses

### 1.1 Operating conditions for bearings in vibratory machinery

Vibratory screens used for grading materials and other vibratory machinery such as road rollers and saw frames are among the machines subjected to the most severe stresses.

The rolling bearings fitted in the exciter units of these machines must support not only high loads and high speeds but also accelerations and centrifugal forces. In many cases, these applications involve adverse environmental conditions such as contamination and moisture. The special spherical roller bearings developed by FAG are matched to the operating conditions in vibratory machinery and have proved highly successful in practical use. In particular, the cages of the rolling bearings are subjected to stresses arising from high radial accelerations. In unfavourable cases, these may be overlaid by axial accelerations as well. The rotating imbalance generates rotating shaft deflection and additional sliding motion within the bearings. This increases the friction and therefore the operating temperature of the bearings. The special spherical roller bearings can support dynamic angular misalignments of up to  $0,15^\circ$ . If larger misalignments must be accommodated, please consult our Application Engineering.

### 1.2 Bearing series and basic designs

FAG special spherical roller bearings for vibratory machinery have main dimensions corresponding to dimension series 23 and 33 (E DIN 616: 1995-01 or ISO 15). For the particular stresses occurring in vibratory machinery, we manufacture all the special spherical roller bearings described in this publication in accordance with specification T41A(D), see also section 1.5.

Very high load carrying capacity is achieved through optimum use of bearing cross-section as a result of further development of spherical roller bearings of series 223..-E1. In the design for vibratory stresses, the bearings are supplied with bore diameters of up to 150 mm. They have sheet steel window cages of high structural fatigue strength, surface hardened and guided on the outer ring. Bearings of dimension series with a bore diameter of more than 150 mm are supplied by us in design A. The inner ring has three rigid ribs. Inertia forces are directly radially outwards by two solid brass cage halves guided on the outer ring. Wider bearings of series 233..-A have an internal construction comparable to bearings of series 223..-A. These bearings are used in special cases where very high load carrying capacity is required.

#### 1.2.1 X-life spherical roller bearings of series 223..-E1

FAG spherical roller bearings of the E1 design have an inner ring without a rib and are characterised by very high load carrying capacity. This advantage is also offered by FAG special bearings for vibratory stresses of design 223..-E1-T41A(D), Figure 1. This is the new FAG standard design for bearings with a bore diameter of 40 up to and including 150 mm (bore code 08 to 30).

After extensive testing, bearings of design 223..-E1-T41A have proved extremely successful in numerous practical applications. The bearing has one sheet steel window half cage guided on the outer ring for each row of rollers. The cage halves are supported via the cage guide ring in the outer ring. The guide ring is of a single piece design. All cage parts are subjected to a special surface hardening process.

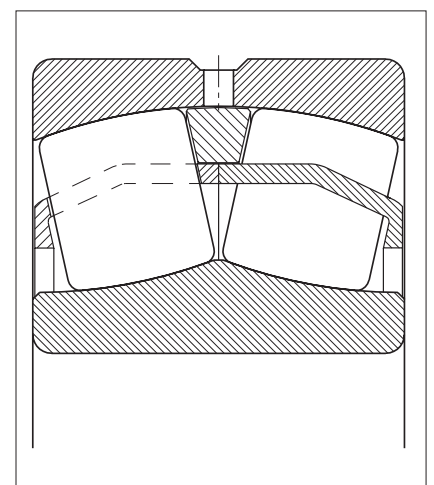

1: X-life design 223..-E1-T41A(D) of special spherical roller bearings for vibratory machinery (bore code 08 to 30)

# FAG spherical roller bearings for vibratory stresses

Bearing series and basic designs · Bearings with tapered bore · Bearings with coated bore · Specification T41A(D)

## 1.2.2 Spherical roller bearings of series 223..-A

If the bore diameter is 160 mm or greater (bore code  $\geq 32$ ), we recommend the proven special spherical roller bearings of design 223..-A-MA-T41A, Figure 2. The bearings have one rigid central rib and two lateral retaining ribs on the inner ring. The two-piece solid brass cage (suffix MA) is guided on the outer ring.

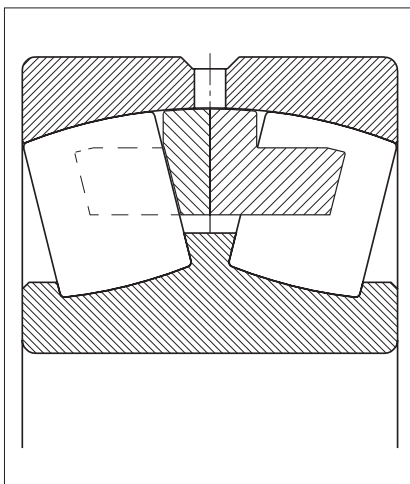

2: Design 223..-A-MA-T41A of special spherical roller bearings for vibratory machinery (bore code  $\geq 32$ )

## 1.2.3 Spherical roller bearings of series 233..-A

Where vibratory machinery requires very high basic load ratings, we can by agreement supply special spherical roller bearings of series 233..-A(S)-MA-T41A with a bore diameter of 100 to 200 mm (bore code 20 to 40). These bearings have three rigid ribs on the inner ring. The split solid brass cage (suffix MA) is guided on the outer ring.

## 1.3 Bearings with tapered bore

In special cases such as saw frames, bearings are also available with a tapered bore (taper 1:12). These designs have the suffix E1-K-T41A or A-K-MA-T41A.

## 1.4 Bearings with coated bore

In order to reduce or prevent fretting corrosion between the bearing bore and the shaft, we can for specific orders (and as standard for 22317-E1-T41D to 22322-E1-T41D) supply spherical roller bearings with a cylindrical bore treated with a thin layer chromium plating. This ensures that the possibility of displacement (non-locating bearing function) between the bearing bore and shaft in response to thermal influences is maintained over and beyond a long period of operation. The bearings with a coated bore correspond in their dimensions and tolerances to, and are interchangeable with, the FAG standard bearings for vibratory machinery. Ordering example for a bearing with a thin layer chromium plated bore: 22324-E1-J24BA-T41A.

Note: This coating is applied to the bearings 22317-E1-T41D to 22322-E1-T41D as standard.

## 1.5 Specification T41A(D)

FAG spherical roller bearings for vibratory machinery are manufactured in accordance with the specification T41A(D). This takes into consideration the particular requirements of the application. The specification defines the tolerances and radial internal clearance of the special spherical roller bearings.

### 1.5.1 Tolerances for bearing bore and outside diameter

Specification T41A(D) prescribes a restriction of the bore tolerance to the upper half of the normal tolerance zone. For the outside diameter, only the centre half of the normal tolerance zone is permissible. In bearings with a tapered bore, the reduced tolerance range applies to the outside diameter only. For tolerance values, see table, Figure 3 (page 4). Through these measures, the sliding fit required for the inner ring is reliably achieved with shaft tolerances g6 or f6 and the interference fit required for the outer ring is reliably achieved with housing tolerance P6. The inner ring does not have pure point load and the outer ring is subjected to circumferential load. The other tolerances are in accordance with tolerance class PN to DIN 620.

# FAG spherical roller bearings for vibratory stresses

Specification T41A(D)

## 1.5.2 Radial internal clearance groups, reduction in radial internal clearance of bearings with tapered bore

Specification T41A(D) prescribes C4 as the standard internal clearance group for all spherical roller bearings of vibrating screen design and it is therefore not necessary to indicate this explicitly. In this way, radial preloading of the bearings is prevented in the event of unfavourable interaction between the different influences such as fits, deformations, etc. This applies especially during the startup and running-in periods, during which the largest temperature differences occur between the inner and outer ring.

### 3: Restricted tolerance according to specification T41A(D)

#### Inner ring

Nominal bearing bore diameter	over incl.	Dimensions in mm					
		30	50	80	120	180	250
		50	80	120	180	250	315

#### Tolerances in $\mu\text{m}$

Deviation $\Delta_{\text{Dmp}}$	0	0	0	0	0	0
	-7	-9	-12	-15	-18	-21

#### Outer ring

Nominal outside diameter	over incl.	Dimensions in mm					
		80	150	180	315	400	500
		150	180	315	400	500	630

#### Tolerances in $\mu\text{m}$

Deviation $\Delta_{\text{Dmp}}$	-5	-5	-10	-13	-13	-15
	-13	-18	-23	-28	-30	-35

### 4: Radial internal clearance of FAG spherical roller bearings

Nominal bearing bore diameter	over incl.	Dimensions in mm													
		30	40	50	65	80	100	120	140	160	180	200	225	250	280
		40	50	65	80	100	120	140	160	180	200	225	250	280	315

#### With cylindrical bore

##### Internal clearance in $\mu\text{m}$

Internal clearance group C3	min	45	55	65	80	100	120	145	170	180	200	220	240	260	280
	max	60	75	90	110	135	160	190	220	240	260	290	320	350	370

Internal clearance group C4	min	60	75	90	110	135	160	190	220	240	260	290	320	350	370
	max	80	100	120	145	180	210	240	280	310	340	380	420	460	500

#### With tapered bore

##### Internal clearance in $\mu\text{m}$

Internal clearance group C3	min	50	60	75	95	110	135	160	180	200	220	250	270	300	330
	max	65	80	95	120	140	170	200	230	260	290	320	350	390	430

Internal clearance group C4	min	65	80	95	120	140	170	200	230	260	290	320	350	390	430
	max	85	100	120	150	180	220	260	300	340	370	410	450	490	540

# FAG spherical roller bearings for vibratory stresses

Specification T41A(D)

It is only necessary to consider a special radial internal clearance for spherical roller bearings in vibratory machinery in rare cases, for example if the material to be screened is hot or the bearing arrangement is subjected to excessive external heat.

In special cases such as saw frames, bearings with an internal clearance other than C4 may be necessary. The suffix for the radial internal clearance, e.g. C3, must then be indicated explicitly. We supply bearings of this design by agreement. For radial internal clearance values of special spherical

roller bearings, see table, Figure 4. Bearings with a tapered bore are mounted on a conical shaft seat or, using a sleeve, on a cylindrical shaft. The reduction in the radial internal clearance during mounting (see table, Figure 5) can be taken as an indication of the seating between the inner ring and shaft.

**5: Reduction in radial internal clearance in mounting of spherical roller bearings with tapered bore (solid shaft)**

Nominal bearing bore diameter		Reduction in radial internal clearance		Displacement on taper 1:12		Sleeve		Control value for minimum radial internal clearance after fitting		
d over mm	incl. mm	min mm	max mm	min mm	max mm	min mm	max mm	CN min mm	C3 min mm	C4 min mm
30	40	0,02	0,025	0,35	0,4	0,35	0,45	0,015	0,025	0,04
40	50	0,025	0,03	0,4	0,45	0,45	0,5	0,02	0,03	0,05
50	65	0,03	0,04	0,45	0,6	0,5	0,7	0,025	0,035	0,055
65	80	0,04	0,05	0,6	0,75	0,7	0,85	0,025	0,04	0,07
80	100	0,045	0,06	0,7	0,9	0,75	1	0,035	0,05	0,08
100	120	0,05	0,07	0,7	1,1	0,8	1,2	0,05	0,065	0,1
120	140	0,065	0,09	1,1	1,4	1,2	1,5	0,055	0,08	0,11
140	160	0,075	0,1	1,2	1,6	1,3	1,7	0,055	0,09	0,13
160	180	0,08	0,11	1,3	1,7	1,4	1,9	0,06	0,1	0,15
180	200	0,09	0,13	1,4	2	1,5	2,2	0,07	0,1	0,16
200	225	0,1	0,14	1,6	2,2	1,7	2,4	0,08	0,12	0,18
225	250	0,11	0,15	1,7	2,4	1,8	2,6	0,09	0,13	0,2
250	280	0,12	0,17	1,9	2,6	2	2,9	0,1	0,14	0,22
280	315	0,13	0,19	2	3	2,2	3,2	0,11	0,15	0,24

# FAG spherical roller bearings for vibratory stresses

## Dimensioning of bearings

### 1.6 Permissible radial acceleration

Since the centrifugal forces are supported against the outer ring, high acceleration forces are possible in special spherical roller bearings for vibratory machinery, see diagram below.

Permissible radial acceleration values of special spherical roller bearings for vibratory machinery

- a)  $n \cdot d_m = 350\,000 \text{ min}^{-1} \cdot \text{mm}$   
Maximum possible values with optimum mounting conditions and oil lubrication, e.g. planetary gearbox
- b)  $n \cdot d_m = 140\,000 \text{ min}^{-1} \cdot \text{mm}$   
Normal operating conditions for saw frames with grease lubrication
- c)  $n \cdot d_m = 230\,000 \text{ to } 300\,000 \text{ min}^{-1} \cdot \text{mm}$   
Normal use for vibrating screens with grease or oil lubrication

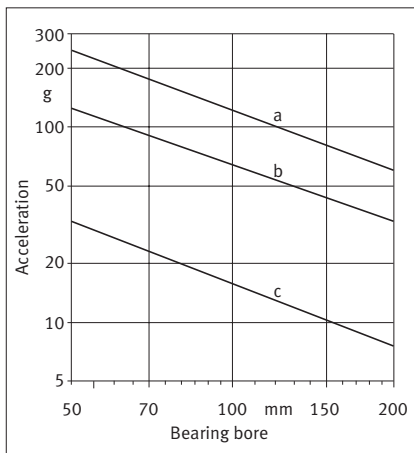

### 1.7 Heat treatment

All FAG spherical roller bearings of series 223 and 233 for vibratory stresses are heat treated such that they are dimensionally stable up to an operating temperature of 200 °C.

### 2 Dimensioning of bearings

Vibrating screen bearings are normally designed for a basic rating life  $L_h$  of between 10 000 and 20 000 hours.

This is calculated as follows:

$$L_h = (C/P)^p \cdot 10^6 / (n \cdot 60) \text{ [h]}$$

C Basic dynamic load rating [kN], see bearing tables, section 5

P Equivalent dynamic load [kN], see sections 2.1 to 2.3

p = 3,33 Life exponent for roller bearings

n Speed [min<sup>-1</sup>]

When determining the equivalent dynamic load P of spherical roller bearings for vibrating applications, the influences that cannot be precisely defined are taken into consideration by means of a safety factor  $f_z$  of 1,2 times the radial bearing load  $F_r$ . Based on practical experience, this gives sufficiently long running times.

More precise calculation can be achieved using the expanded adjusted rating life  $L_{hnm}$  to ISO 281, Supplementary Sheet 1 (see also Catalogue HR 1). The fatigue limit load  $C_u$  required in this case is stated in the dimension tables.

#### 2.1 Two bearing screen with circle throw

Figure 6 shows a schematic of an imbalance-type two bearing screen. The bearing load imposed by the centrifugal force of the screen box is derived from the mass of the screen box, the vibration radius and the speed in accordance with the following formula:

$$F_r = \frac{1}{z} \cdot \frac{m}{10^3} \cdot r \cdot \omega^2 =$$

$$= \frac{1}{z} \cdot \frac{G}{g} \cdot r \left( \frac{\pi \cdot n}{30} \right)^2 \text{ [kN]} \quad (1)$$

$F_r$  Radial bearing load [kN]

m Mass of screen box [kg]

r Vibration radius [m]

$\omega$  Angular velocity [1/s]

G Weight of screen box [kN]

g Acceleration due to gravity [9,81 m/s<sup>2</sup>]

n Speed [min<sup>-1</sup>]

z Number of bearings

The vibration radius r in two bearing screens can be determined from the ratio of the screen box weight to the exciter weight. Since two bearing screens generally operate between the critical range approaching the static amplitude, it can be assumed that the common centroidal axis of the two masses (screen box and exciter) is maintained during rotation, Figure 7.

Based on this precondition:

$$G \cdot r = G_1 (R - r)$$

The vibration radius is thus

$$r = \frac{G_1 \cdot R}{G + G_1} \text{ [m]} \quad (2)$$

where

G Weight of screen box [kN]

$G_1$  Weight of exciter [kN]

R Distance between centre of gravity of exciter and bearing axis [m]

r Vibration radius of screen box [m]

$G_1 \cdot R$  Imbalance moment of exciter [kN m]

$G + G_1$  Total weight supported by springs [kN]

# Dimensioning of bearings

Two bearing screen with circle throw

If (2) is incorporated in (1) and the expression is transformed, the radial bearing load is

$$F_r = \frac{1}{z} \cdot \frac{G_1}{g} \cdot \frac{R}{1 + \frac{G_1}{G}} \cdot \left( \frac{\pi \cdot n}{30} \right)^2 \text{ [kN]} \quad (3)$$

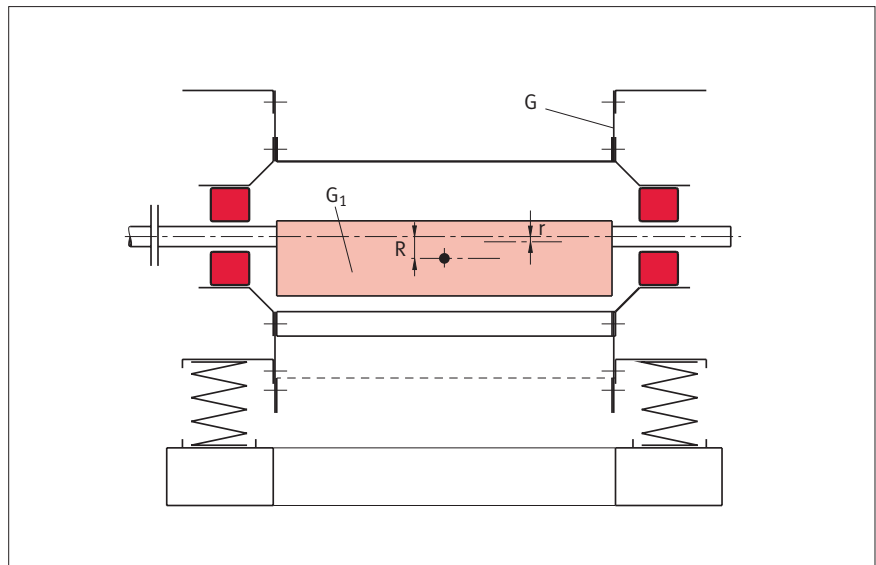

6: Schematic of two bearing screen with circle throw

## Example

Weight of screen box  $G = 35 \text{ kN}$

Vibration radius  $r = 0,003 \text{ m}$

Speed  $n = 1200 \text{ min}^{-1}$

Number of bearings  $z = 2$

Bearing load according to formula (1)

$$F_r = \frac{1}{2} \cdot \frac{35}{9,81} \cdot 0,003 \left( \frac{\pi \cdot 1200}{30} \right)^2 = 84,5 \text{ [kN]}$$

The equivalent dynamic bearing load required in order to determine the necessary basic dynamic load rating of the bearing is then

$$P = 1,2 \cdot F_r = 1,2 \cdot 84,5 = 101 \text{ [kN]}$$

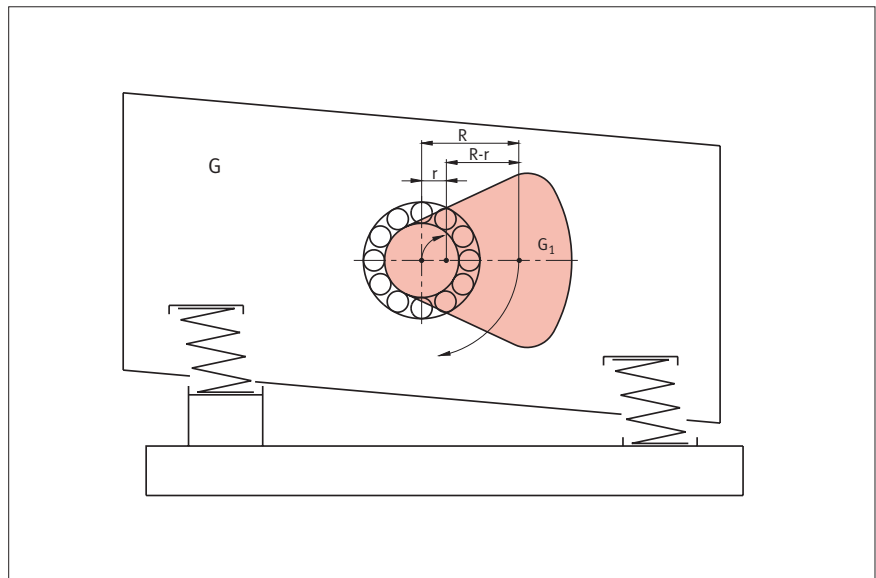

7: The vibration radius is determined by the ratio of the screen box weight to the exciter weight

# Dimensioning of bearings

Two bearing screen with straight line motion

## 2.2 Two bearing screen with straight line motion

In principle, the exciter in a two bearing screen with straight line motion comprises two contra-rotating synchronous circular throw systems, Figure 8.

The forces are determined by resolving the rotating centrifugal force vectors of the imbalance shafts into two components, in the direction of the line connecting the two shafts and the direction perpendicular to this line. It can be seen that the components lying in the direction of the connecting line cancel each other out, whereas the perpendicular components add up, generating a harmonic pulsating inertia force that induces straight line vibration of the screen box. Since the so-called static amplitude is induced in the direction of vibration due to the supercritical operation and the common centroidal axis of the screen box and the imbalance masses does not vary during vibration, the bearing loads are as follows:

In the direction of vibration

$$F_{r \min} = \frac{1}{z} \cdot \frac{m}{10^3} \cdot r \cdot \omega^2 =$$

$$= \frac{1}{z} \cdot \frac{G}{g} \cdot r \cdot \left( \frac{\pi \cdot n}{30} \right)^2 =$$

$$= \frac{1}{z} \cdot \frac{G_1}{g} \cdot (R - r) \cdot \left( \frac{\pi \cdot n}{30} \right)^2 \quad [\text{kN}] \quad (4)$$

where

r [m] Vibration radius

R [m] Distance between the centres of gravity of the exciters and the corresponding bearing axes

Perpendicular to the direction of vibration

$$F_{r \max} = \frac{1}{z} \cdot \frac{G_1}{g} \cdot R \cdot \left( \frac{\pi \cdot n}{30} \right)^2 \quad [\text{kN}] \quad (5)$$

giving a somewhat larger bearing load.

In contrast to a circle throw screen, in which the bearing load is constant, the bearing load in a straight line screen alternates twice during one revolution of the exciter shafts between  $F_{r \max}$  and  $F_{r \min}$ . If formula (4) is compared with formula (1), it can be seen that the minimum bearing load of a screen with straight line motion is exactly the same as the bearing load of a comparable circle throw screen. For a straight line screen with a load varying according to a sinusoidal function, the bearing load can be determined according to the formula

$$F_r = 0,68 \cdot F_{r \max} + 0,32 \cdot F_{r \min} \quad [\text{kN}]$$

Whereas the bearing load in a circle throw screen can be determined simply from data for the screen box G, vibration radius r and speed n, these data only allow calculation of the minimum load in a straight line screen. For more precise calculation, it is also necessary to know either the exciter mass  $G_1$  or the distance R between the centres of gravity of the exciters from their bearing axes. It is then possible using

$$G \cdot r = G_1 \cdot (R - r) \quad [\text{kN m}]$$

to determine the unknown quantity.

## Example

Weight of screen box  $G = 33 \text{ kN}$

Weight of exciter  $G_1 = 7,5 \text{ kN}$

Radius  $r = 0,008 \text{ m}$

Speed  $n = 900 \text{ min}^{-1}$

Number of bearings  $z = 4$

$$\text{With } R = \frac{r(G + G_1)}{G_1}$$

$$= \frac{0,008(33 + 7,5)}{7,5} = 0,0432 \text{ [m]}$$

this gives, according to (4) and (5)

$$F_{r \min} = \frac{1}{4} \cdot \frac{33}{9,81} \cdot 0,008 \cdot \left( \frac{\pi \cdot 900}{30} \right)^2$$

$$= 59,8 \text{ [kN]}$$

$$F_{r \max} = \frac{1}{4} \cdot \frac{7,5}{9,81} \cdot 0,0432 \cdot \left( \frac{\pi \cdot 900}{30} \right)^2$$

$$= 73,3 \text{ [kN]}$$

Bearing load

$$F_r = 0,68 \cdot 73,3 + 0,32 \cdot 59,8 =$$

$$= 69 \text{ [kN]}$$

The equivalent dynamic bearing load required in order to determine the necessary basic dynamic load rating of the bearing is then

$$P = 1,2 \cdot 69 = 83 \text{ [kN]}$$

## Dimensioning of bearings

Two bearing screen with straight line motion

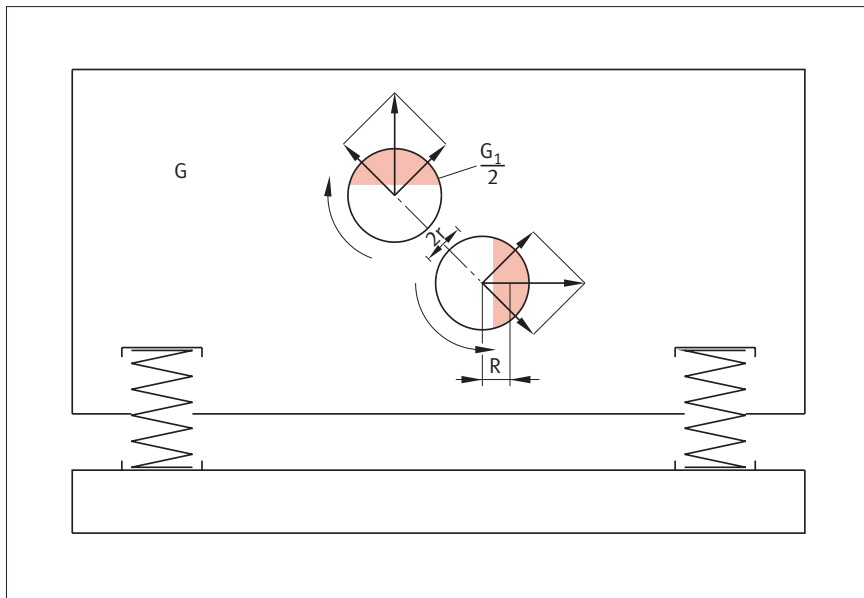

8: Schematic of two bearing screen with straight line motion

# Dimensioning of bearings

## Eccentric screen

### 2.3 Eccentric screen

In contrast to a two bearing screen, the vibration radius of an eccentric screen is a function of the eccentricity of the shaft. The bearing for the two inner rings is determined using the same formula as for the circle throw screen

$$F_r = \frac{1}{z} \cdot \frac{G}{g} \cdot r \cdot \left( \frac{\pi \cdot n}{30} \right)^2 \quad [kN] \quad (1)$$

where  $r$  is the eccentric radius of the crankshaft and  $z$  is the number of inner bearings, Figure 9.

The influence of the support springs on the loading of the inner bearings can be regarded as negligible.

The outer bearings of the eccentric screen are only lightly loaded since the centrifugal force of the screen box during idling is compensated by counterweights ( $G_2$ ). The load on these bearings is not constant; it varies according to a sinusoidal pattern due to the support springs on the screen box. In operation, the material in the box interferes with the balanced condition of the machine. This places additional load on the outer bearings. However, this additional load is very small.

The selection of bearings is based on the shaft diameter. This results in bearings whose load carrying capacity is so high that a fatigue life calculation is unnecessary. Since these bearings do not undergo vibration, spherical roller bearings of the standard design are sufficient.

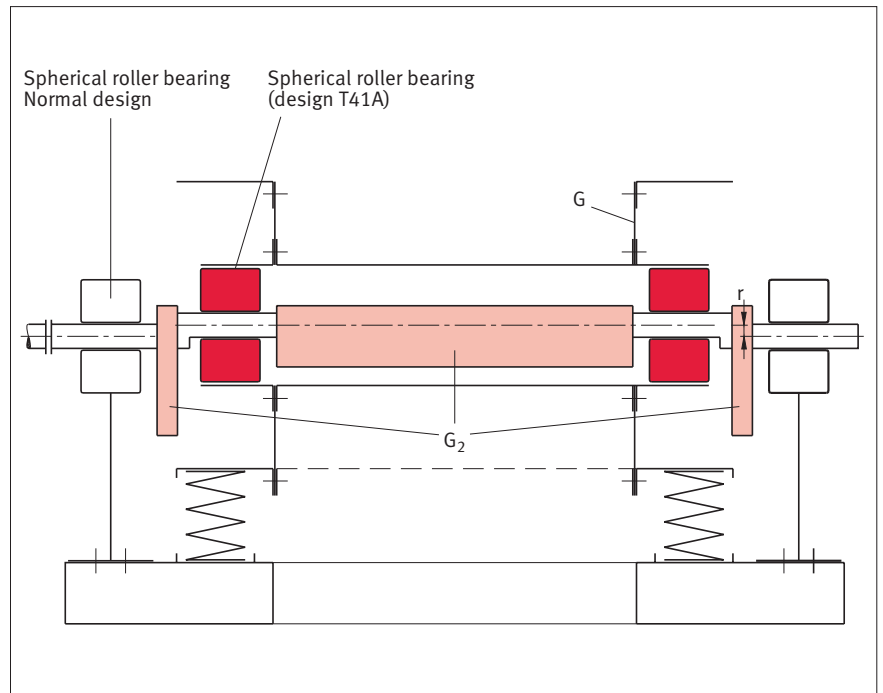

9: Schematic of an eccentric screen

#### Example

Weight of screen box  $G = 60$  kN  
 Eccentric radius  $r = 0,005$  m  
 Speed  $n = 850$  min<sup>-1</sup>  
 Number of bearings  $z = 2$   
 Inner bearings: Bearing load according to formula (1)

$$F_r = \frac{1}{2} \cdot \frac{60}{9,81} \cdot 0,005 \cdot \left( \frac{\pi \cdot 850}{30} \right)^2 = 121 \text{ kN}$$

The equivalent dynamic bearing load required in order to determine the necessary basic dynamic load rating of the bearing is then  $P = 1,2 \cdot 121 = 145$  [kN]

# Dimensioning of bearings

Nomogram for calculation of centrifugal force

## 2.4 Nomogram for calculating the centrifugal force of the imbalance masses or the centrifugal force of the screen box mass

$F_{max}$ ,  $F_{min}$  and  $F$  are centrifugal forces  
 $n$  is the speed [ $min^{-1}$ ]  
 $r$  is the vibration radius [m]  
 $R$  is the distance between the centre of gravity of the exciter and the bearing axis [m]

$b$  is the acceleration [ $m/s^2$ ]  
 $G$  is the weight of the screen box [kN]  
 $G_1$  is the weight of the imbalance mass [kN]  
 $g = 9,81$  is the acceleration due to gravity [ $m/s^2$ ]

$$F_{max} = \frac{G_1}{g} \cdot R \cdot \left(\frac{\pi \cdot n}{30}\right)^2 \text{ [kN]}$$

$$F_{min} = \frac{G_1}{g} \cdot (R - r) \cdot \left(\frac{\pi \cdot n}{30}\right)^2 \text{ [kN]}$$

$$F = \frac{G}{g} \cdot r \cdot \left(\frac{\pi \cdot n}{30}\right)^2 \text{ [kN]}$$

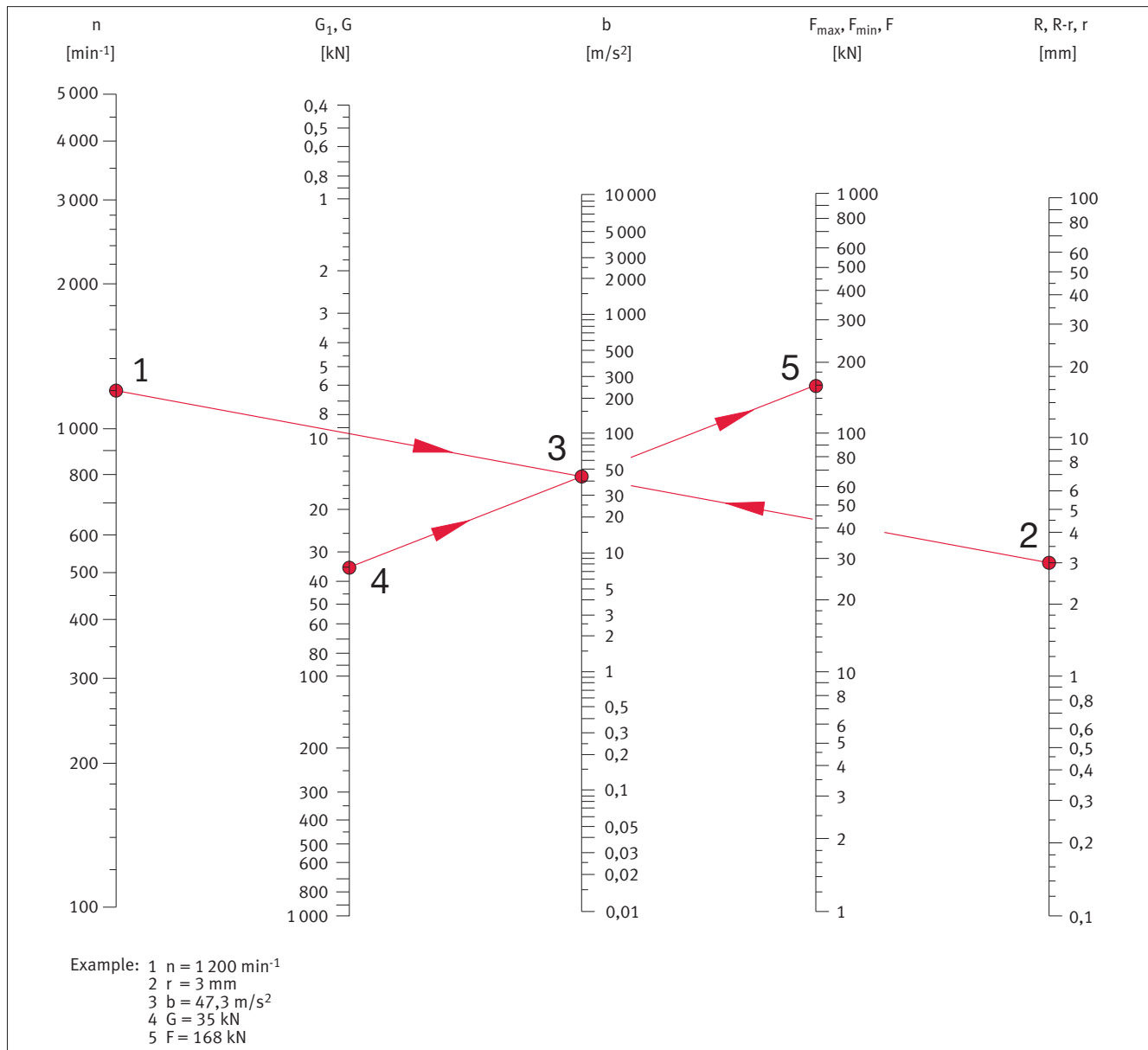

# Dimensioning of bearings

Nomogram for calculation of basic load ratings

## 2.5 Nomogram for calculating the basic dynamic load rating required

The following are required in order to calculate the basic dynamic load rating C [kN]:

- n Speed [min<sup>-1</sup>]
- L<sub>h</sub> Basic rating life [h]
- P Equivalent dynamic load [kN]

In two bearing screens with circle throw and inner bearings with eccentric screens

$$P = 1,2 \cdot \frac{F}{z} \text{ [kN]}$$

In two bearing screens with straight line motion

$$P = 1,2 \cdot \left( \frac{0,68 \cdot F_{\max} + 0,32 \cdot F_{\min}}{z} \right)$$

where 1,2 is the safety factor  
z is the number of bearings  
F is the centrifugal force according to nomogram 1 (section 2.4)

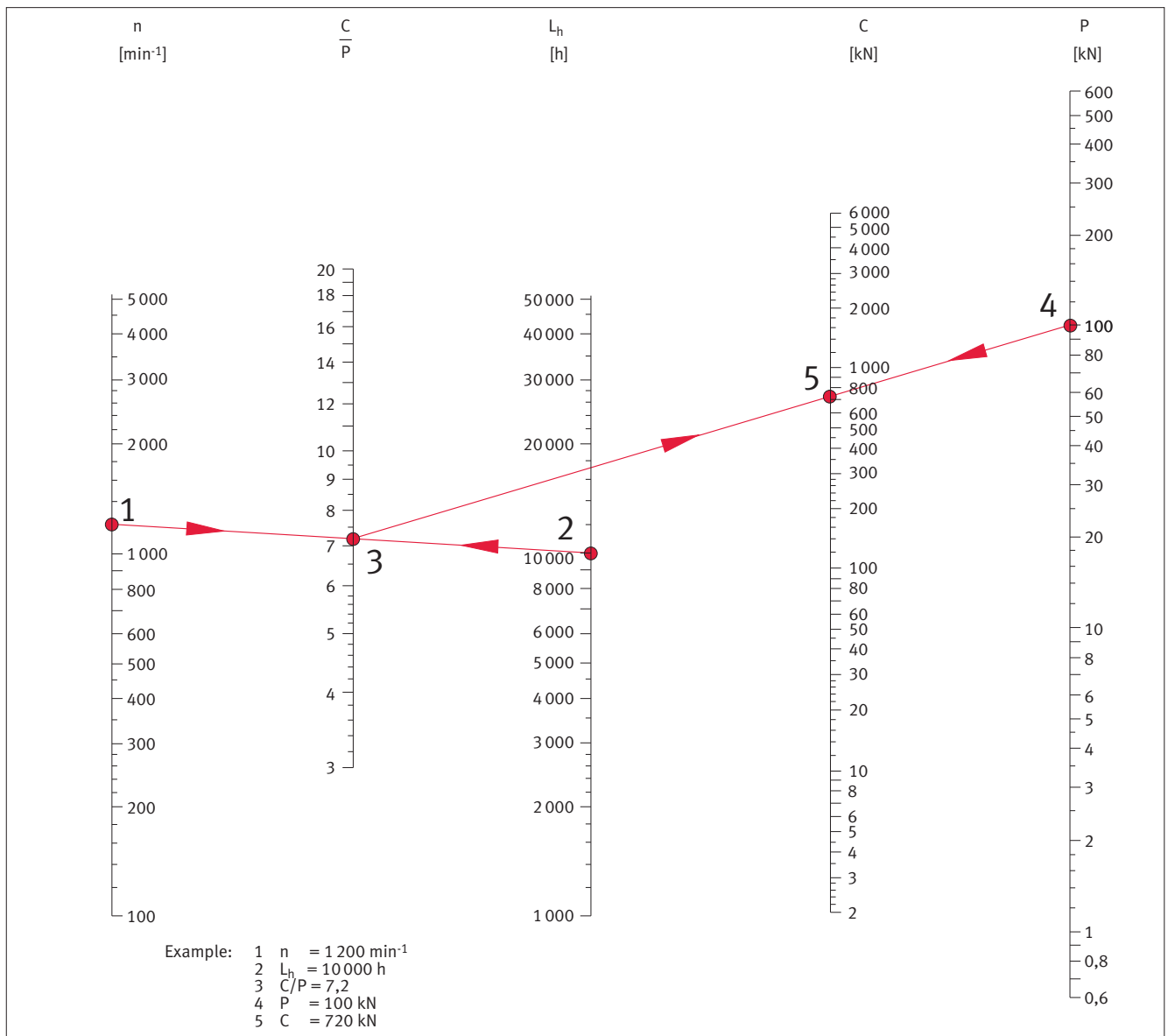

# Design of bearing arrangements

Two bearing screen with circle throw (grease lubrication)

## 3 Design of bearing arrangements

### 3.1 Two bearing screen with circle throw (grease lubrication)

Figure 10 shows the essential bearing arrangement design of a two bearing screen with circle throw and grease lubrication. The imbalance shaft is supported in two special spherical roller bearings FAG 223..-E1-T41A. The bearing on the drive side is fitted as a locating bearing while the opposing bearing is a non-locating bearing.

#### Fitting and dismantling of bearings

After inspection of the adjacent parts, the bearing is then mounted in the housing bore. Smaller bearings can be pressed in while cold. For larger bearings, the housing is heated uniformly to the point where the interference between the bearing outer ring and housing bore is eliminated. As the housing cools down, the interference fit is achieved. The bearing and housing are then slid onto the shaft.

For dismantling, it is easier to press the bearing out of the housing if the guard tube flange (part A in Figure 10) is replaced by a screw mounted ring equipped with several extraction screws.

#### Lubrication and sealing

A favourable option is to feed the grease as shown here via the circumferential groove and the lubrication holes in the bearing

outer ring. In this way, the fresh grease is fed directly to the rolling and sliding surfaces of the rolling bearing, ensuring uniform lubrication of both rows of rollers. The fresh grease displaces the old, possibly contaminated grease from the interior of the bearing. On the inner side of the bearing arrangement, the old grease escapes via the gap in the grease

baffle and collects in the guard tube. On the outer side, it collects at the grease collector pocket, from which it is periodically removed. The bearing is sealed against external influences by a labyrinth that can be relubricated and whose sealing action can be further increased by a V ring on the innermost labyrinth passage.

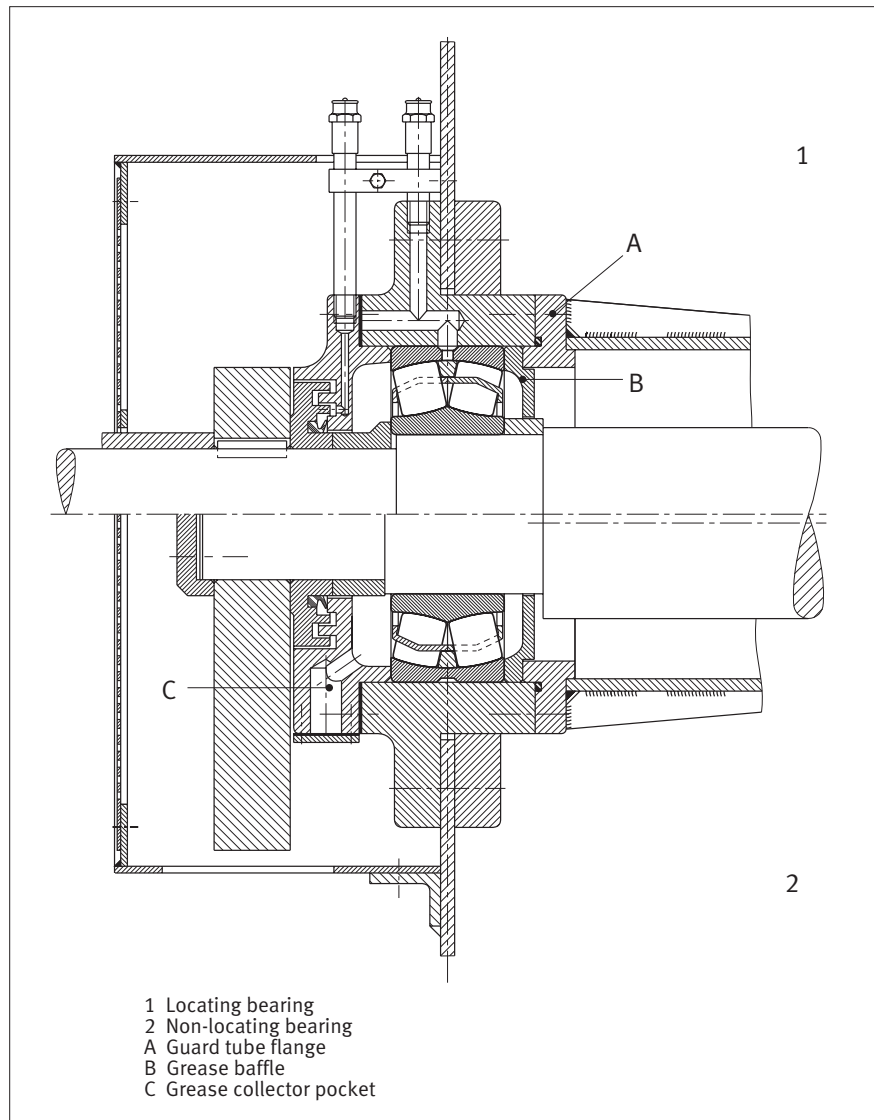

10: Two bearing screen with circle throw (grease lubrication)

# Design of bearing arrangements

Two bearing screen with circle throw (oil sump lubrication)

## 3.2 Two bearing screen with circle throw (oil sump lubrication)

Figure 11 shows the essential bearing arrangement design of a two bearing screen with circle throw and oil sump lubrication. Sealing against entry of external contamination is provided by a grease-filled labyrinth that can be relubricated. A splash ring with a oil collector groove prevents egress of oil. On the bearing side, the sealing area is shielded by a flinger ring.

In order to prevent the grease in the labyrinth entering the oil cavities, a V ring is fitted between the labyrinth and splash ring. The connecting hole in the lower section of the housing equalises the oil sump level between the two sides of the bearing. The oil level should be such that the lowest roller in the bearing is immersed to approximately half its diameter in oil when the bearing is stationary. At this level, there is an overflow hole that is closed off after the housing is filled. The oil outlet screw contains a small permanent magnet that draws wear particles out of the oil. The oil quantity should be as large as possible so that the oil does not need to be changed too frequently. In general, the shaft guard tube is used as an additional oil reservoir.

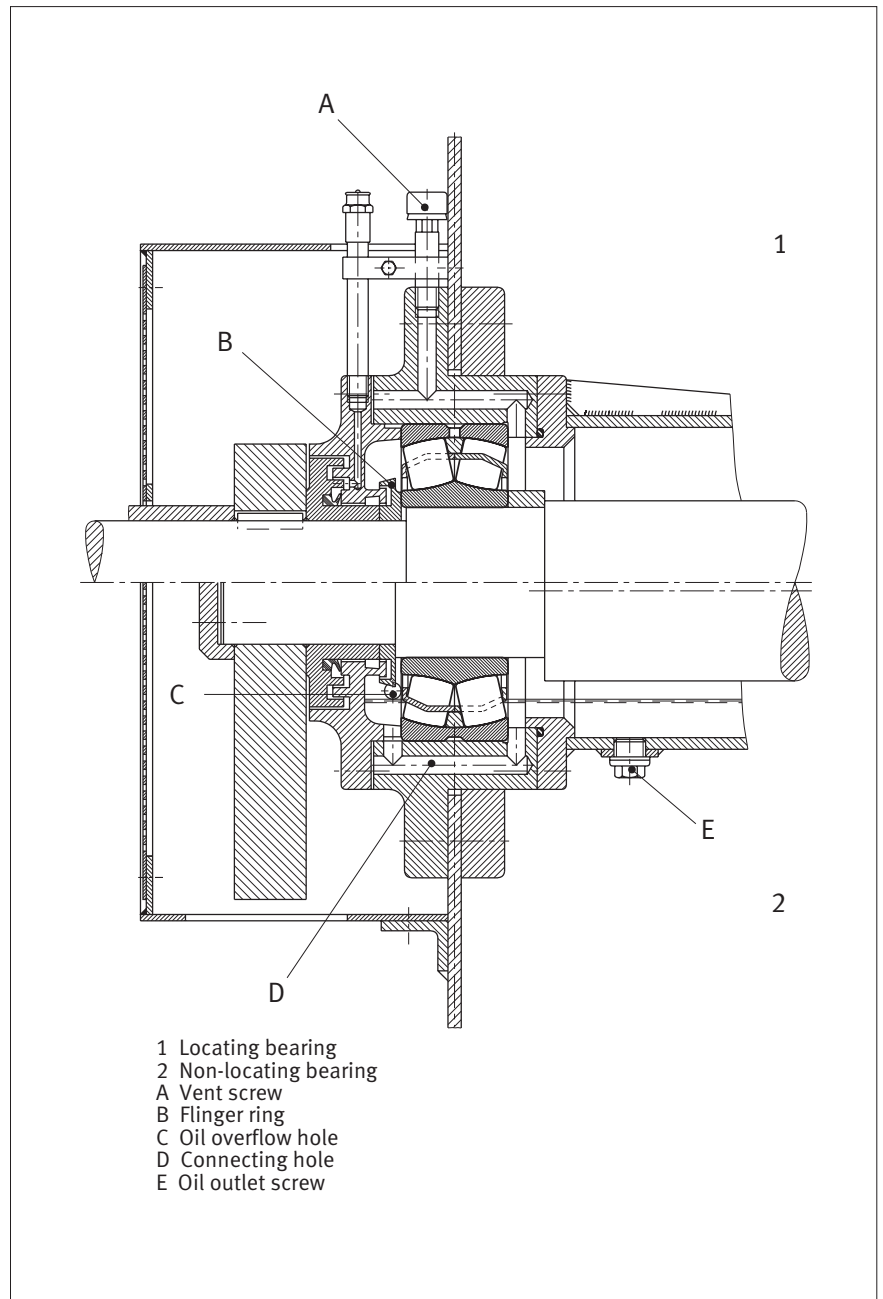

11: Two bearing screen with circle throw (oil sump lubrication)

## Design of bearing arrangements

Two bearing screen with circle throw (recirculating oil lubrication)

### 3.3 Two bearing screen with circle throw (recirculating oil lubrication)

The design of the bearing arrangement with recirculating oil lubrication shown in Figure 12 is similar to that of the bearing arrangement with oil sump lubrication (see section 3.2). The connecting hole in the lower section of the housing equalises the oil level between the two sides of the bearing.

The sealing arrangement is taken from the oil sump lubrication. The oil outlet hole is located at such a level that, even if the oil feed is interrupted, there is still an emergency oil reserve available. The oil is fed via the lubrication groove and lubrication holes in the bearing outer ring. Oil filtration is absolutely essential (cf. section 4.2.2).

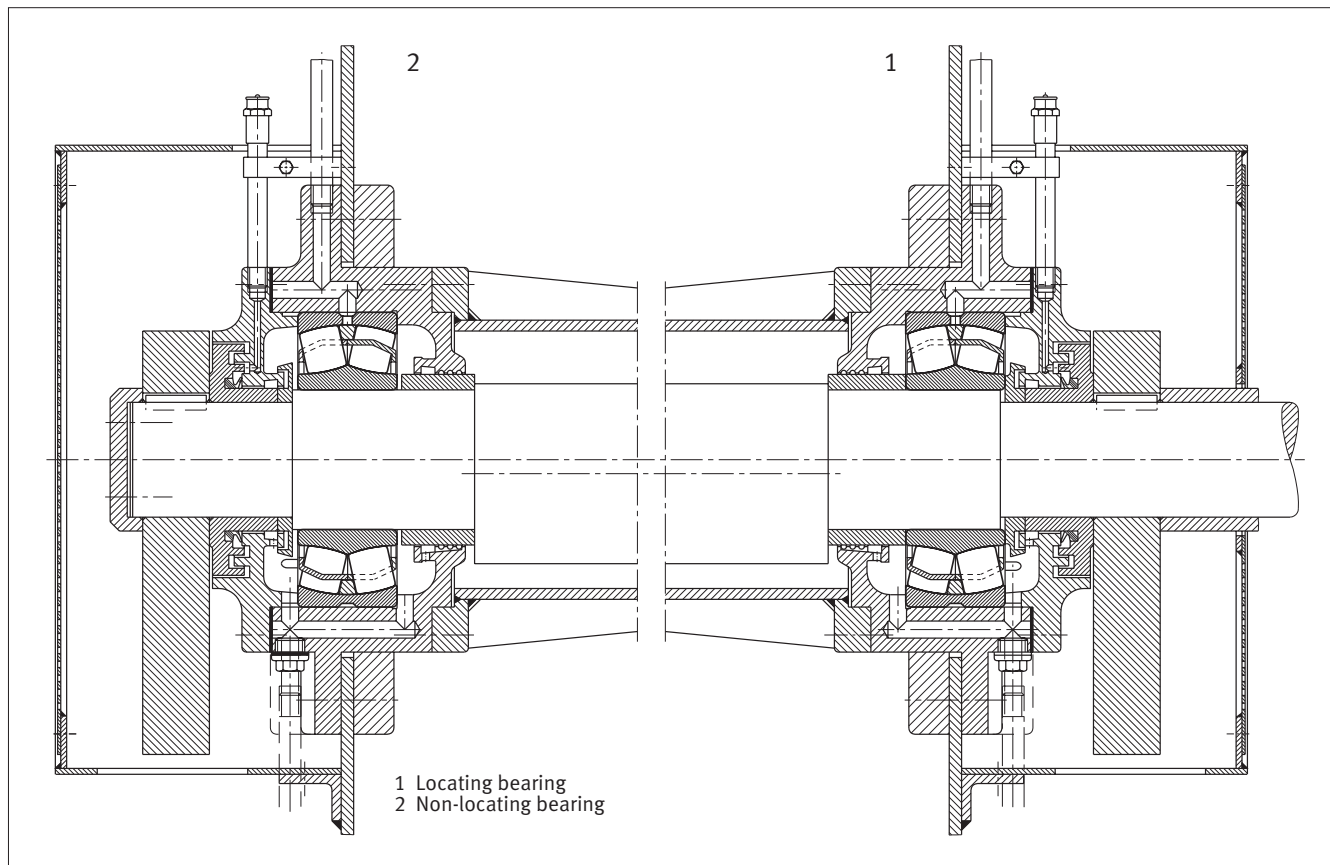

12: Two bearing screen with circle throw (recirculating oil lubrication)

## Design of bearing arrangements

Two bearing screen with straight line motion (oil splash lubrication)

### 3.4 Two bearing screen with straight line motion (oil splash lubrication)

Figure 13 shows the bearing arrangement of an exciter for a two bearing screen with straight line motion. The two contra-rotating, synchronously geared imbalance shafts are fitted with FAG special spherical roller bearings 223..-E1-T41A. The bearings on the gear side are fitted as locating

bearings in order to prevent disruption to the gear cycling behaviour if length variations occur (temperature differences). The bearings are lubricated by the oil thrown off by the gears and a flinger shield. Baffle plates on the lower halves of the housing end faces ensure that the oil level reaches approximately the centre of the lowest roller in the bearings.

The passage for the drive shaft is equipped with a splash ring seal and – in order to prevent ingress of contamination – with a labyrinth. A V ring can also be fitted between the labyrinth and splash ring. The oil level is just high enough that the lower gear and flinger shield are immersed in the oil sump. The oil level is monitored by lateral oil level indicators.

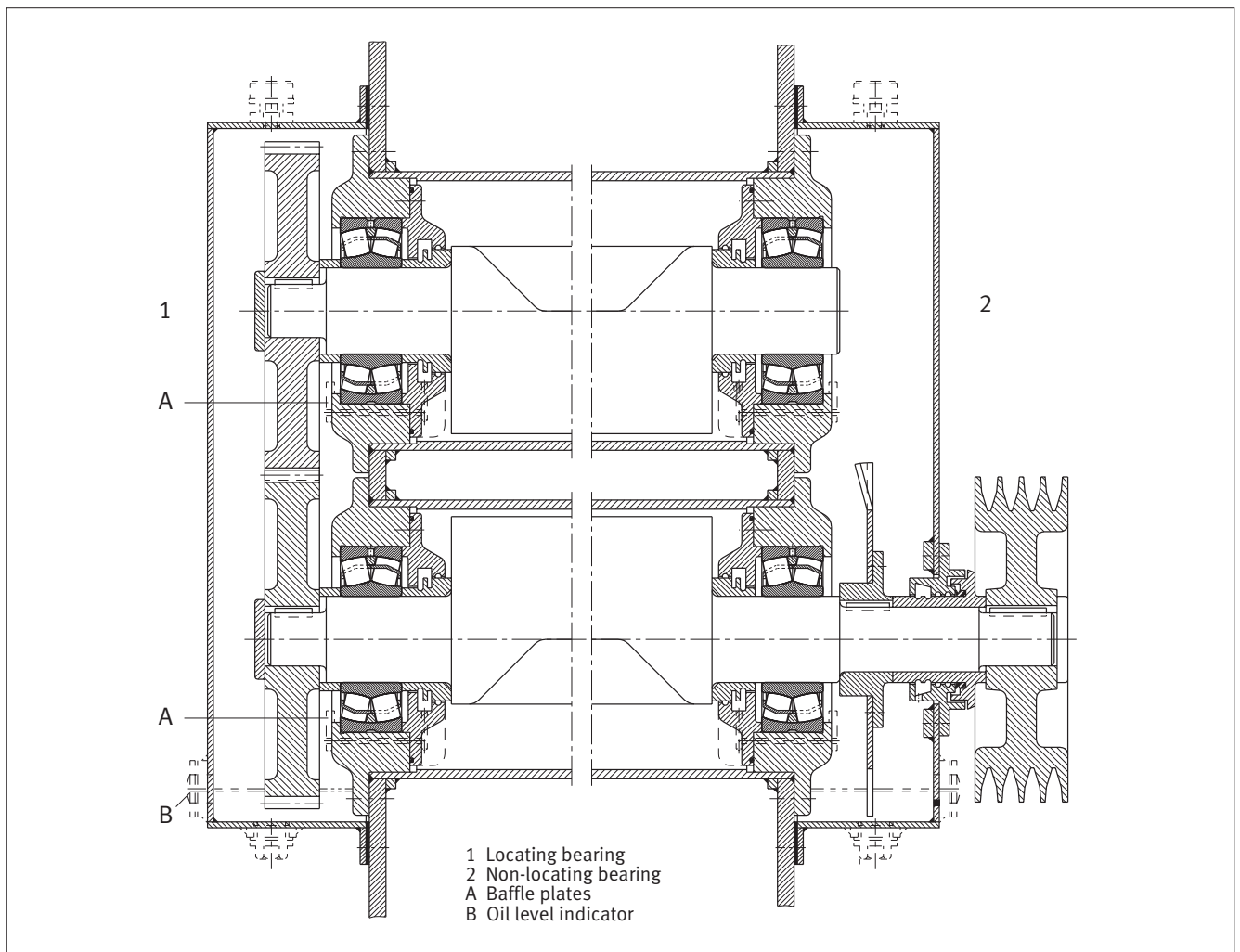

13: Two bearing screen with straight line motion (oil splash lubrication)

# Design of bearing arrangements

Four bearing screen (grease lubrication)

## 3.5 Four bearing screen (grease lubrication)

Figure 14 shows the eccentric shaft of a four bearing screen. Since the stresses acting on the inner bearings are comparable with those acting on the bearings of a two bearing screen, these positions are fitted with FAG special spherical roller bearings of series 223..-E1-T41A. Although the interaction of the rotating screen box centrifugal force and the directionally constant spring forces does not give a pure point load on the inner ring, the fits selected are generally the same as for the two bearing screen. The outer rings have a P6 fit in the housing, while the inner rings have an f6 or g6 fit on the shaft. One of the two inner bearings is fitted as a locating bearing, while the other is a non-locating bearing with an inner ring that can be displaced along the shaft. In all other respects, the design of the inner bearing arrangement shown is identical to the bearing arrangement for a two bearing screen with grease lubrication. Conditions are different in the outer bearings. In order to ensure that, if possible, imbalance forces are not transmitted to the foundations and the bearing load remains low, the imbalance moment of the screen box in the eccentric screen is compensated by means of counterweights. During idling, the outer bearings are only subjected to the forces exerted by the support springs. The support springs are preloaded to such an extent that the outer bearings are subjected to a sinusoidally pulsating but directionally constant radial load.

Although the precisely balanced condition is disrupted during operation by the material in the box – the spring forces are overlaid by an uncompensated rotating centrifugal force – and the load direction may therefore vary within a certain angle, the bearing fits are determined on the assumption that the outer ring is subjected to point load.

A loose fit must therefore be selected for the outer rings in the housing bore. The inner rings are normally located on the shaft – as shown – using extraction sleeves. The bearing on the drive side is fitted as a locating bearing while the opposing bearing is a

non-locating bearing with an outer ring capable of axial displacement.

Normal machining tolerances that have proved effective for the outer bearing seats are

Shaft: h8/h9  
(shaft tolerance for location by extraction sleeve)

Housing: H7

Since the outer bearings do not undergo translation movement and are only subject to light loads, normal spherical roller bearings with a tapered bore and normal internal clearance can be selected.

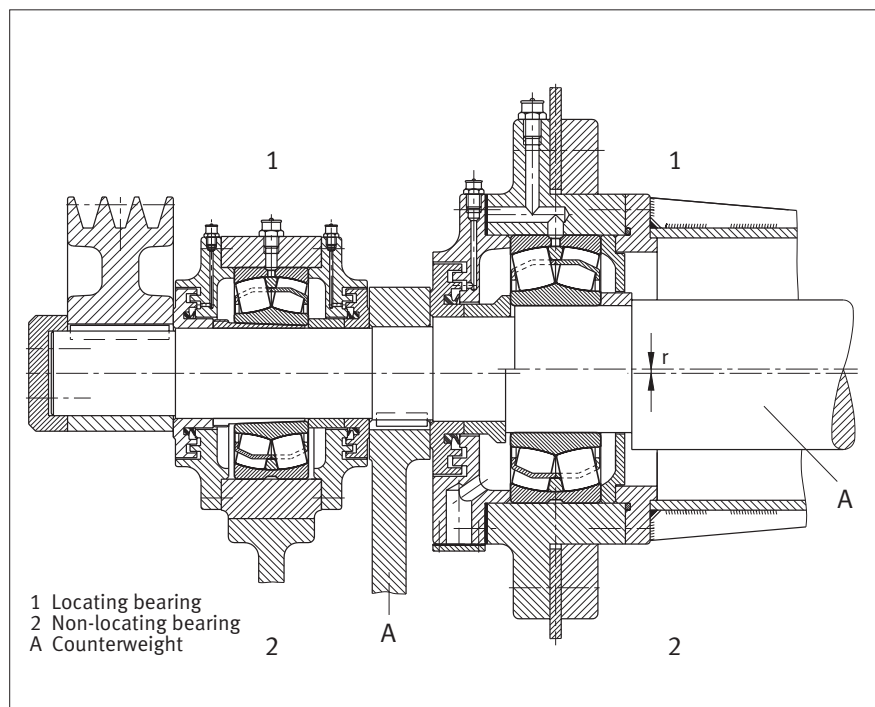

14: Four bearing screen (grease lubrication)

# Lubrication of bearings

Grease lubrication · Oil lubrication

## 4 Lubrication of bearings

Spherical roller bearings in vibratory machinery are subjected to very high operating loads and adverse environmental conditions.

The lubricant type, lubrication method and lubricant supply must be carefully selected and matched in order to fulfil the requirements for functional suitability and service life of the vibratory machinery bearings.

Depending on the operating conditions, bearing size and particular requirements of the plant operator, lubrication using grease or oil can be selected.

### 4.1 Grease lubrication

In most vibratory machinery, the special spherical roller bearings are lubricated using grease. Grease lubrication is normally used up to a speed parameter  $n \cdot d_m = 300\,000 \text{ min}^{-1} \cdot \text{mm}$  ( $n$  operating speed,  $d_m$  mean bearing diameter). Only greases that have been tested and proven should be used, see section 4.3. Any change of grease type should be avoided if possible.

For normal operating conditions in vibratory machinery, we recommend lithium soap greases with EP (extreme pressure) and anti-corrosion additives corresponding to penetration class 2. The minimum requirements described in DIN 51 825 are not sufficient for this application. Instead, the suitability of greases for use in the rolling bearing must be demonstrated as is the case with, for example, the FAG greases Arcanol MULTITOP and LOAD400.

In applications with higher operating temperatures, for example in screens for hot materials or where the bearings may in special cases undergo considerable heating by the material in the box, special greases with high thermal stability should be used.

The base oil viscosity required is dependent on the operating conditions. The aim should be to achieve a viscosity ratio  $\kappa = v/v_1 \geq 2$ , where  $v$  is the operating viscosity and  $v_1$  is the reference viscosity, see also Catalogue HR 1.

When rolling bearings are fitted, the internal cavities of the bearings must be filled to capacity with grease. In order to prevent excessive working of the lubricant, the housing cavities on both sides of the bearing must remain empty so that the excess grease can be dispersed into the free space in the housing during the startup phase. It is recommended that relubrication should be carried out via the lubrication groove and the lubrication holes that are present as standard in the outer ring of all FAG special spherical roller bearings. This ensures uniform supply of lubricant to both rows of rollers. Where rolling bearings are relubricated from the side, the distance between the housing wall and the end face of the bearing should be as small as possible so that the grease can reach the bearing interior quickly and without losses. The grease outlet hole should be located on the opposite side of the bearing. In bearing arrangements for vibratory machinery, it is advisable to relubricate the bearings with small quantities of grease at short intervals.

The table in Figure 15 gives relubrication quantities as a function of bearing size and speed. These relubrication quantities relate to a relubrication interval of 50 operating hours and normal operating temperatures.

If continuous relubrication is carried out by means of a central lubricant supply system, the grease quantity  $m_1$  required per hour per bearing can be determined using the formula  $m_1 = 0,00004 \cdot D \cdot B$

where

$m_1$  = required grease quantity [g/h]

$D$  = bearing outside diameter [mm]

$B$  = bearing width [mm]

The labyrinth seals should be relubricated once per week, or more frequently if operating conditions are unfavourable (heavy exposure to dust, moisture, high operating temperature). The grease should be the same as that used in the rolling bearings.

### 4.2 Oil lubrication

If the speeds are above the normal range for grease lubrication (i. e. speed parameter  $n \cdot d_m > 300\,000 \text{ min}^{-1} \cdot \text{mm}$ ), oil lubrication must be provided. Oil lubrication may also be necessary if there is heating by external sources or for reasons of maintenance. For lubrication of bearings, we recommend mineral oils or synthetic oils with EP (extreme pressure) and anti-corrosion additives, see also section 4.3. Good quality multi-grade oils can also be used.

The viscosity ratio  $\kappa = v/v_1$  ( $v$  = operating viscosity,  $v_1$  = reference viscosity) should be  $\geq 2$ .

# Lubrication of bearings

Grease lubrication · Oil lubrication

## 15: Relubrication quantities in g for spherical roller bearings 223 in vibratory machinery (relubrication interval: 50 operating hours)

Bore code	Speed min <sup>-1</sup>																
	500	600	700	800	900	1000	1200	1400	1600	1800	2000	2200	2400	2600	2800	3000	3200
08	5	5	5	5	5	5	5	5	5	5	5	5	5	5	5	5	5
09	5	5	5	5	5	5	5	5	5	5	5	5	5	5	5	10	10
10	5	5	5	5	5	5	5	5	5	5	5	5	10	10	10	10	15
11	5	5	5	5	5	5	5	5	5	10	10	10	10	10	15	15	20
12	5	5	5	5	5	5	5	5	5	10	10	10	10	15	15		
13	5	5	5	5	5	5	5	10	10	10	10	15	15	20			
14	5	5	5	5	5	5	10	10	10	15	15	20	25				
15	5	5	5	5	5	5	10	10	10	15	20	25					
16	5	5	5	10	10	10	10	10	15	20	25						
17	5	5	10	10	10	10	10	15	20	25	35						
18	10	10	10	10	10	10	15	20	25	30	40						
19	10	10	10	10	10	15	15	25	35	45							
20	10	10	10	10	15	15	20	30	40								
22	10	10	15	15	20	20	30	50	70								
24	15	15	20	25	30	35	55	85									
26	15	20	20	25	35	40	65										
28	20	25	30	35	45	60	100										
30	25	30	40	50	65	90											
32	25	35	45	60	80	100											
34	30	40	55	80	110	140											
36	35	50	65	90	120												
38	45	65	90	130													
40	50	70	100	150													
44	70	105	160														
48	105	170															
52	120	200															
56	190																

### 4.2.1 Oil sump lubrication (bath lubrication)

Oil sump lubrication is normally used to a speed parameter  $n \cdot d_m = 300\,000 \text{ min}^{-1} \cdot \text{mm}$ ; with frequent oil changes, it can be used

up to  $n \cdot d_m = 500\,000 \text{ min}^{-1} \cdot \text{mm}$ . In this lubrication method, the lubricant is conveyed to the rolling contact points by any gears, the imbalance mass or the rolling elements themselves. The oil level in the machine or

bearing housing must be sufficiently high that the gears or imbalance masses are dipped in the oil and create a swirling effect. When the bearing is stationary, the lowest roller must be half immersed in the oil, Figure 16.

# Lubrication of bearings

## Oil lubrication

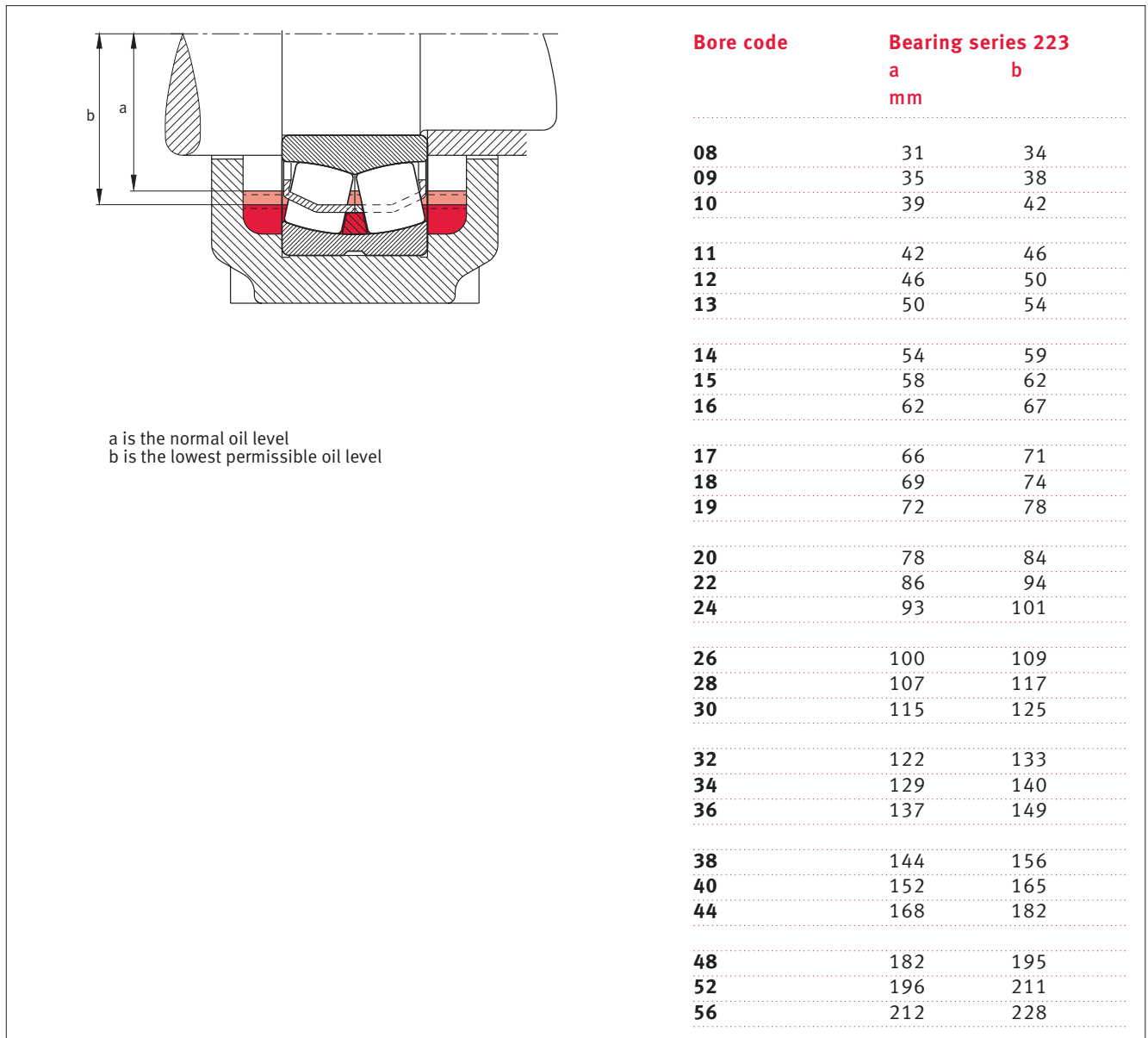

16: Determining the oil level at standstill

A sufficiently large oil quantity will extend the oil change interval. If the cavities in the housings are not sufficient, the shaft guard tube between the bearings can also be used as an oil reservoir or an additional container can be provided.

The oil change interval is dependent on the contamination and the ageing condition of the oil. Guide values for the oil quantity and oil change intervals as a function of the bearing bore are given in Figure 17. For further details, see publication

WL 81 115/4 EA “Lubrication of rolling bearings”.

We recommend regular oil inspection, since the results of such inspections will allow more precise determination of oil change intervals.

# Lubrication of bearings

## Oil lubrication

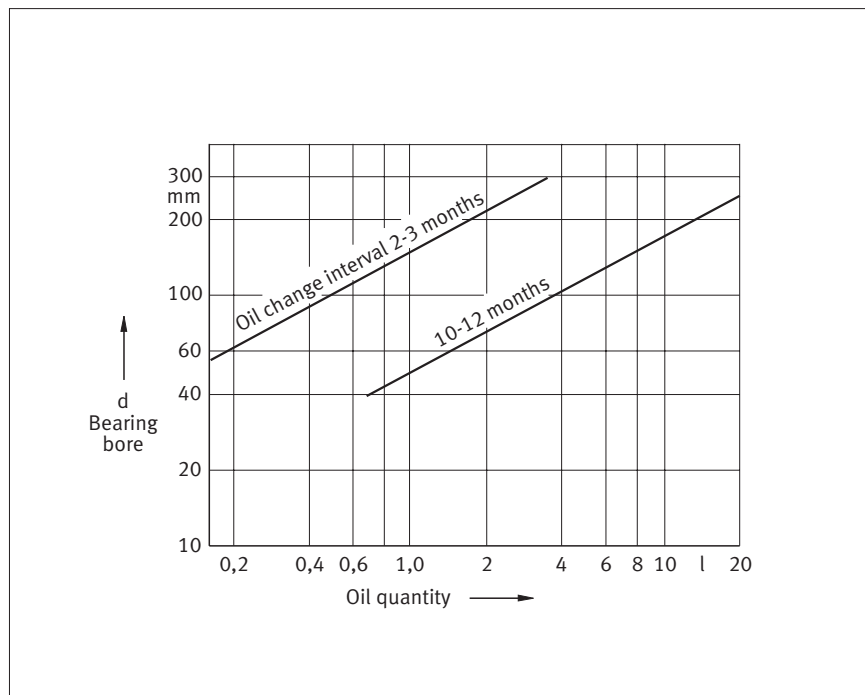

17: Oil quantity and oil change interval as a function of bearing bore diameter

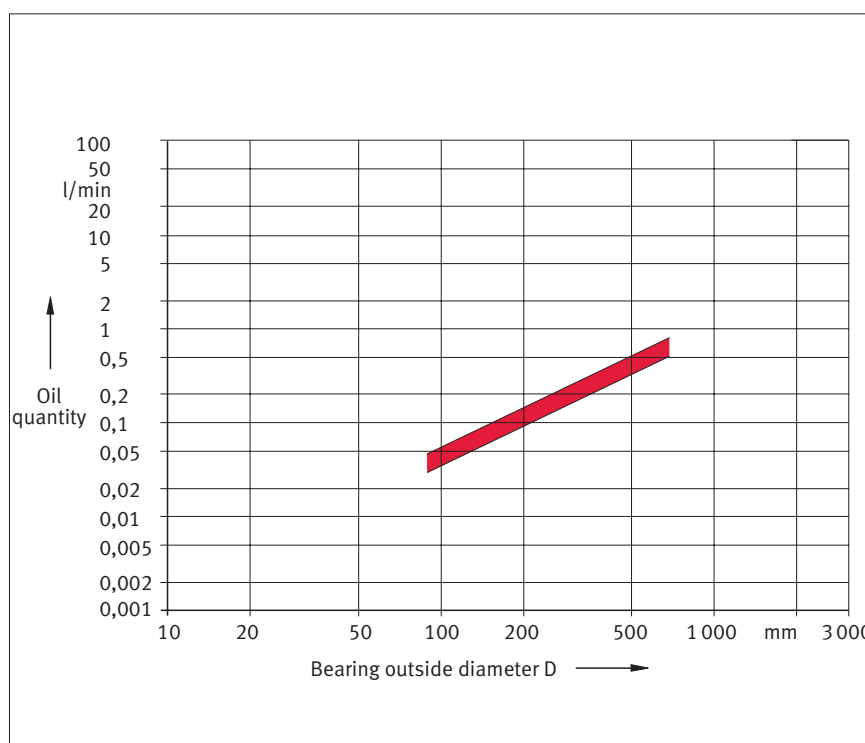

18: Minimum oil flow rate for spherical roller bearings of series 223 in vibratory machinery

### 4.2.2 Recirculating oil lubrication

If the speed parameter is higher than the permissible value for bath lubrication or where special conditions apply (increased heat dissipation required, insufficiently large oil cavities), recirculating oil lubrication must be used. The oil should be fed via the lubrication groove and lubrication holes in the bearing outer ring.

Guide values for normal oil flow rates can be determined from the diagram in Figure 18.

In order to prevent oil backing up in the lubrication system, the cross-sections of the unpressurised return ducts must be adapted to the cross-sections of the feed ducts (4 to 5 times larger).

In recirculating oil lubrication, it is absolutely essential that a filter is provided for retaining wear particles and contaminants in order to prevent impairment of the bearing operating life.

Through evaluation of regular oil inspections, the oil change intervals can be matched more accurately to the operating conditions.

# Lubrication of bearings

Recommended lubricants

## 4.3 Recommended lubricants

### **Greases for vibrating screen bearing arrangements**

The quality of FAG Arcanol rolling bearing greases is carefully monitored by means of 100% inspection of every batch.

Greases for normal temperatures:

Arcanol MULTITOP  
Arcanol LOAD400  
Arcanol LOAD220

Greases for high temperatures:

Arcanol TEMP120

In the case of greases that have not been subjected to our incoming goods inspection, we cannot make any statements regarding batch fluctuations, formulation changes or production influences.

However, we maintain a list of suitable commercial greases that is regularly updated. The current issue can be requested from us by telephoning +49 9721 91-3883.

### **Oils for vibrating screen bearing arrangements**

If oils are to be used for this application, it must be demonstrated that the additives package is effective in the rolling bearing.

In principle, it is possible to use mineral oils and synthetic oils, with the exception of silicone oils. It is not advisable to use oils with viscosity index improvement agents. A current list of oils that may be recommended can be requested from us by telephoning +49 9721 91-3883.

# FAG special spherical roller bearings for vibratory machinery

With cylindrical bore, series 223...-E1-T41A(D)

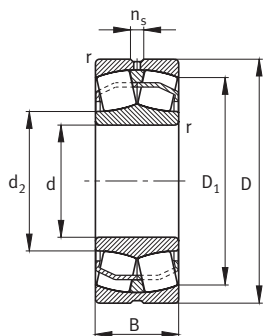

FAG special spherical roller bearings for vibratory machinery, with cylindrical bore, series 223...-E1-T41A(D)															
Shaft	Dimensions							Basic load ratings			Fatigue limit load	Limiting speed	Reference speed	Designation	Mass
	d	D	B	r	ns	D <sub>1</sub>	d <sub>2</sub>	dyn.	stat.	C <sub>ur</sub>	n <sub>G</sub>	n <sub>B</sub>	Bearing	≈	
	mm							C <sub>r</sub>	C <sub>0r</sub>	C <sub>ur</sub>	min <sup>-1</sup>		FAG	kg	
<b>40</b>	40	90	33	1,5	4,8	76	52,4	156	150	13,1	7 500	5 800	<b>22308-E1-T41A</b>	1,05	
<b>45</b>	45	100	36	1,5	6,5	84,7	58,9	186	183	16,1	6 700	5 300	<b>22309-E1-T41A</b>	1,39	
<b>50</b>	50	110	40	2	6,5	92,6	63	228	224	20,3	6 000	4 950	<b>22310-E1-T41A</b>	1,9	
<b>55</b>	55	120	43	2	6,5	101,4	68,9	265	260	23,9	5 600	4 650	<b>22311-E1-T41A</b>	2,27	
<b>60</b>	60	130	46	2,1	6,5	110,1	74,8	310	310	28	5 000	4 300	<b>22312-E1-T41A</b>	2,89	
<b>65</b>	65	140	48	2,1	9,5	119,3	83,2	355	365	32,5	4 800	3 950	<b>22313-E1-T41A</b>	3,57	
<b>70</b>	70	150	51	2,1	9,5	128	86,7	390	390	36,5	4 500	3 850	<b>22314-E1-T41A</b>	4,21	
<b>75</b>	75	160	55	2,1	9,5	136,3	92,4	440	450	40,5	4 300	3 650	<b>22315-E1-T41A</b>	5,18	
<b>80</b>	80	170	58	2,1	9,5	145,1	98,3	500	510	45	4 300	3 450	<b>22316-E1-T41A</b>	6,27	
<b>85</b>	85	180	60	3	9,5	154,2	104,4	540	560	50	4 000	3 300	<b>22317-E1-T41D</b>	7,06	
<b>90</b>	90	190	64	3	12,2	162,5	110,2	610	630	55	3 600	3 100	<b>22318-E1-T41D</b>	8,51	
<b>95</b>	95	200	67	3	12,2	171,2	116	670	695	60	3 000	2 900	<b>22319-E1-T41D</b>	9,69	
<b>100</b>	100	215	73	3	12,2	183,3	124,2	815	915	75	3 000	2 550	<b>22320-E1-T41D</b>	12,8	
<b>110</b>	110	240	80	3	15	204,9	143,1	950	1 060	91	2 600	2 250	<b>22322-E1-T41D</b>	17,7	
<b>120</b>	120	260	86	3	15	222,4	150,8	1 080	1 160	103	2 600	2 080	<b>22324-E1-T41A</b>	22,5	
<b>130</b>	130	280	93	4	17,7	240	162,2	1 250	1 370	117	2 400	1 870	<b>22326-E1-T41A</b>	28	
<b>140</b>	140	300	102	4	17,7	255,7	173,5	1 460	1 630	132	2 200	1 700	<b>22328-E1-T41A</b>	35,1	
<b>150</b>	150	320	108	4	17,7	273,2	185,3	1 630	1 860	147	2 000	1 550	<b>22330-E1-T41A</b>	42,2	

All spherical roller bearings of series 223...-E1-T41A(D) are X-life designs.

# FAG special spherical roller bearings for vibratory machinery

With cylindrical bore, series 223...-A-MA-T41A

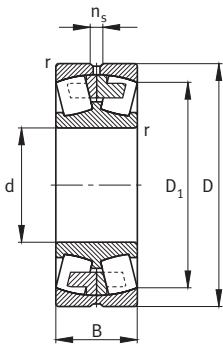

FAG special spherical roller bearings for vibratory machinery, with cylindrical bore, series 223...-A-MA-T41A													
Shaft	Dimensions						Basic load ratings		Fatigue limit load	Limiting speed	Reference speed	Designation	Mass
	d	D	B	r	$n_s$	$D_1$	dyn.	stat.	$C_{ur}$	$n_G$	$n_B$	Bearing	≈
	mm			min		≈	$C_r$ kN	$C_{0r}$	kN	min <sup>-1</sup>		FAG	kg
<b>160</b>	160	340	114	4	17,7	289	1 430	1 900	136	2 000	1 490	<b>22332-A-MA-T41A</b>	52,7
<b>170</b>	170	360	120	4	17,7	305	1 600	2 120	144	1 800	1 380	<b>22334-A-MA-T41A</b>	59,5
<b>180</b>	180	380	126	4	23,5	324	1 700	2 240	229	1 500	1 280	<b>22336-A-MA-T41A</b>	72,2
<b>190</b>	190	400	132	5	23,5	339	1 860	2 500	173	1 500	1 220	<b>22338-A-MA-T41A</b>	81
<b>200</b>	200	420	138	5	23,5	359	2 080	2 800	189	1 400	1 130	<b>22340-A-MA-T41A</b>	93,5
<b>220</b>	220	460	145	5	23,5	392	2 320	3 350	217	1 300	980	<b>22344-A-MA-T41A</b>	120





Conmutador: +52(55) 5305-1320  
Fax: +52(55) 5305-1326  
Nextel ID: 52\*40085\*2  
Lada sin Costo México: 01800 552 9428  
mail: [ventas@rodamientos-samper.com.mx](mailto:ventas@rodamientos-samper.com.mx)