

DODGE®

**DODGE® PARA-FLEX®
G-SERIES COUPLINGS**

**SUPPLEMENT TO
PT COMPONENTS
ENGINEERING CATALOG**



BALDOR
DODGE

CONTENTS



PARA-FLEX G-SERIES

Features/Benefits	PT-2
Specifications/How to Order/Nomenclature	PT-3
PARA-FLEX GFB Selection/Dimensions	PT-4
PARA-FLEX GTL Selection/Dimensions	PT-7
PARA-FLEX GTL Accessories	PT-8
PARA-FLEX Grip Tight Selection/Dimensions	PT-13
PARA-FLEX Grip Tight Accessories	PT-14
Engineering/Technical	PT-15
Part Number Index	PT-21

Table of Contents

Features/Benefits

Specifications/How to Order/
Nomenclature

Selection/Dimensions

Accessories
Engineering/Technical



PARA-FLEX G-SERIES

PARA-FLEX GTL, GT & GFB Flange

- PXGFB finished bore flange provides greater bore capacity than existing PXFBX flange
 - Larger bore size permits downsizing to a smaller coupling
- PXGTL flange accepts larger TAPER-LOCK bushings than existing PXTL flange
 - Larger bore size permits downsizing to a smaller coupling
- PXGT flange accepts GRIP TIGHT "thin wall" bushings
 - Largest available bushed bore size
 - Larger bore size permits downsizing to a smaller coupling
- Fewer parts = easier installation
 - Internal clamp ring is integrated into flange
 - Fewer flange bolts
- Faster installation and reduced maintenance time:
 - Total PARA-FLEX installation time reduced approximately 35%
 - Element locking nut allows for the "fastest tire change in the industry"
- Locking nut provides improved grip of element
 - Allows higher element torque ratings

GRIP TIGHT® Bushing

- Patented technology
- GRIP TIGHT "thin wall" bushing provides largest bore size capability
 - Larger bore size permits downsizing to a smaller coupling
- No keyway required (keyed shafting can be used if desired)
 - No keyway = manufacturing savings
 - No keyway = reduced vibration
 - No keyway = maintenance savings
- Can be used with commercial shafting
 - Lower shaft tolerance = less shaft preparation = shaft manufacturing (grinding) savings
- Concentric contact on shaft = less vibration
 - less wear/damage to coupled equipment
 - better equipment efficiencies
- Easy on & reliable mounting from coupling side (not coupling end)
 - Installation savings vs. TAPER-LOCK and QD bushings
- No fretting corrosion or setscrew marks on the shaft
 - Shaft maintenance and replacement savings
- Proven GRIP TIGHT technology used in DODGE bearing and gear products

PARA-FLEX "Problem Solver" Element

- Industry leading 5-year warranty
 - Total cost of ownership savings
- Highest combined misalignment capability (parallel, axial & angular)
 - Longer element life
 - Total cost of ownership savings
 - Dampens vibrations
 - Handles varying torque & shock loads
- Tire cord limits catastrophic element failures
 - No unexpected process shutdowns
 - Warranty and process savings
- Element fatigue indicators
 - Allows for scheduled maintenance
- Lower service factor adds vs. Polyurethane element
 - For temperatures >150°F
 - For severe applications
 - Results in a smaller coupling
- Element can be installed on misaligned shafts
 - Fast, simple element installation and replacement





PARA-FLEX GFB

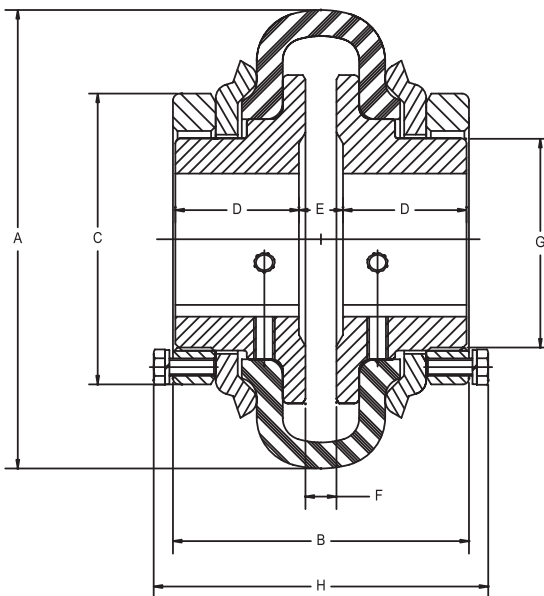

PARA-FLEX GFB FINISHED BORE WITH SS & KEYWAY

COUPLING SIZE	MIN BORE	MAX. BORE (STD KEY)	MAX. BORE (SHAL-LOW KEY)	HP/100	TORQUE (IN-LBS)	MAX RPM	A DIA	B	C DIA	D	E	F	G DIA	H ⁽¹⁾	WEIGHT (LBS.) ⁽²⁾	INERTIA (LB-FT ²) ⁽³⁾
PX50GFB	1/2	1-11/16	1-7/8	2.00	1260	4500	5.25	3.44	3.34	1.38	0.60	0.45	2.55	4.24	6.4	0.09
PX60GFB	7/8	2-3/8	2-3/4	3.72	2340	4000	6.50	4.30	4.71	1.65	0.82	0.64	3.53	5.14	11.2	0.29
PX80GFB	1	3-3/16	3-1/2	7.15	4502	3100	8.38	5.01	6.09	1.98	0.97	0.73	4.71	6.13	23.1	0.99
PX100GFB	1-7/8	4-1/8	4-1/2	8.58	6250	2600	10.00	5.56	7.25	2.29	0.98	0.98	5.89	6.16	46.3	2.93

(1) BEFORE CLAMPING THE ELEMENT

(2) WEIGHT OF COMPLETE COUPLING AT MAX BORE

(3) INERTIA OF COMPLETE COUPLING AT MAX BORE

SELECTION/DIMENSIONS



PARA-FLEX GFB

Coupling Size	Bore* (IN.)	Flange Assembly Description	Flange Assembly Part Number	Element Part Number
PX50GFB	1/2	PX50GFB-RB	000302	011105
	1/2	PX50GFB008	000303	
	5/8	PX50GFB010	000304	
	7/8	PX50GFB014	000305	
	1-1/8	PX50GFB102	000306	
	1-3/8	PX50GFB106	000307	
	1-9/16	PX50GFB109	000359	
	1-5/8	PX50GFB110	000360	
	1-11/16	PX50GFB111	000361	
	1-3/4	PX50GFB112	000362△	
	1-13/16	PX50GFB113	000363△	
1-7/8	PX50GFB114	000364△		
PX60GFB	7/8	PX60GFB-RB	000308	011106
	7/8	PX60GFB014	000309	
	1-1/8	PX60GFB102	000310	
	1-3/8	PX60GFB106	000311	
	1-5/8	PX60GFB110	000312	
	1-7/8	PX60GFB114	000313	
	2-1/8	PX60GFB202	000314	
	2-3/8	PX60GFB206	000365	
	2-7/16	PX60GFB207	000366△	
	2-1/2	PX60GFB208	000367△	
	2-5/8	PX60GFB210	000368△	
	2-11/16	PX60GFB211	000369△	
	2-3/4	PX60GFB212	000370△	
PX80GFB	1	PX80GFB-RB	000315	011108
	1-5/8	PX80GFB110	000380	
	1-3/4	PX80GFB112	000381	
	1-7/8	PX80GFB114	000316	
	2-1/8	PX80GFB202	000317	
	2-3/8	PX80GFB206	000318	
	2-7/8	PX80GFB214	000319	
	3-1/8	PX80GFB302	000371	
	3-3/16	PX80GFB303	000372	
	3-1/4	PX80GFB304	000373△	
	3-3/8	PX80GFB306	000374△	
	3-7/16	PX80GFB307	000375△	
	3-1/2	PX80GFB308	000376△	

* For additional PXGFB bores not listed above, check with DODGE Marketing

△ Key furnished for these sizes only.

COMPLETE COUPLING CONSISTS OF:

(2) GFB FLANGE ASSEMBLIES

(1) ELEMENT



PARA-FLEX GFB

Coupling Size	Bore* (IN.)	Flange Assembly Description	Flange Assembly Part Number	Element Part Number
PX100GFB	1-7/8	PX100GFB-RB	000251	011110
	1-7/8	PX100GFB114	000252	
	1-15/16	PX100GFB115	000253	
	2	PX100GFB200	000254	
	2-1/8	PX100GFB202	000255	
	2-3/16	PX100GFB203	000256	
	2-1/4	PX100GFB204	000257	
	2-3/8	PX100GFB206	000258	
	2-1/2	PX100GFB208	000259	
	2-5/8	PX100GFB210	000260	
	2-3/4	PX100GFB212	000261	
	2-7/8	PX100GFB214	000262	
	3	PX100GFB300	000263	
	3-1/8	PX100GFB302	000264	
	3-1/4	PX100GFB304	000265	
	3-3/8	PX100GFB306	000266	
	3-1/2	PX100GFB308	000267	
	3-5/8	PX100GFB310	000268	
	3-3/4	PX100GFB312	000269	
	3-7/8	PX100GFB314	000270	
4	PX100GFB400	000271		
4-1/8	PX100GFB402	000272		
4-1/4	PX100GFB404	000273Δ		
4-3/8	PX100GFB406	000274Δ		
4-1/2	PX100GFB408	000275Δ		

* For additional PXGFB bores not listed above, check with DODGE Marketing
 Δ Key furnished for these sizes only.

COMPLETE COUPLING CONSISTS OF:

- (2) GFB FLANGE ASSEMBLIES
- (1) ELEMENT

PARA-FLEX ELEMENTS - PART NUMBERS

Element Size	Standard Part No.	Neoprene (1) Part No.	Cordless (2) Part No.	Weight (Lbs)
PX50	011105	011296	011285	0.7
PX60	011106	011297	011286	1.2
PX80	011108	011299	011288	2.2
PX100	011110	011301	011290	2.5

- (1) Neoprene element ratings are the same as the standard natural rubber element range. (Green sticker or painted mark)
- (2) Cordless elements have an average static torsional stiffness 25% of the standard element and approximately 25% of the torque rating. (White sticker or painted mark)



PARA-FLEX GTL

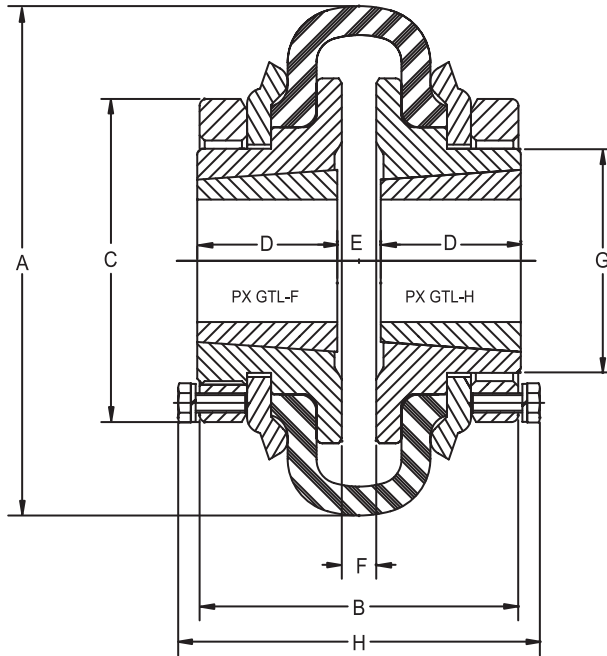

PARA-FLEX GTL WITH TAPER-LOCK BUSHINGS

COUPLING SIZE	BUSHING SIZE	MAX. BORE	HP/100	TORQUE (IN-LBS)	MAX RPM	A DIA	B	C DIA	D	E	F	G DIA	H	WEIGHT (LBS.) ⁽¹⁾	INERTIA (LB-FT ²) ⁽²⁾
PX50GTL	1215	1-1/4	2.00	1260	4500	5.25	3.60	3.34	1.50	0.52	0.45	2.55	4.24	6.4	0.09
PX60GTL	2012	2-1/8	3.72	2340	4000	6.50	4.30	4.71	1.25	0.82	0.64	3.53	5.14	11.2	0.29
PX80GTL	2517	2-11/16	7.15	4502	3100	8.38	5.01	6.09	1.75	0.89	0.73	4.71	6.13	23.1	0.99
PX100GTL	3020	3-1/4	8.58	6250	2600	10.00	5.547	7.67	2.00	0.95	0.95	5.89	6.16	46.3	2.93

(1) WEIGHT OF COMPLETE COUPLING WITH BUSHING AT MAX BORE

(2) INERTIA OF COMPLETE COUPLING WITH BUSHING AT MAX BORE

(3) D = LENGTH OF BUSHING

COUPLING SIZE	FLANGE ASSEMBLY PART NUMBER		ELEMENT PART NUMBER
	TYPE F	TYPE H	
PX50GTL	000335	000377	011105
PX60GTL	000336	000378	011106
PX80GTL	000337	000379	011108
PX100GTL	000276	000277	011110

COMPLETE COUPLING CONSISTS OF:

(2) GTL FLANGE ASSEMBLY COMBINATIONS CAN BE HH, FF, FH, HF

(2) SELECT APPROPRIATE TL BUSHINGS FROM PAGES PT-8 through PT-12

(1) ELEMENT



TAPER-LOCK BUSHINGS

TL Bush Size	BORE	P/N Integral Key	P/N Keyway	WT.	Bushing Keyway	Shaft Keyway REF	Key Size REF
1215	1/2"		119001	0.9	1/8 x 1/16	1/8 x 1/16	1/8 x 1/8
	9/16"		119002	0.9			
	5/8"		119003	0.8	3/16 x 3/32	3/16 x 3/32	3/16 x 3/16
	11/16"		119004	0.8			
	3/4"		119005	0.8			
	13/16"		119006	0.8			
	7/8"		119007	0.8			
	15/16"		119008	0.8	1/4 x 1/8	1/4 x 1/8	1/4 x 1/4
	1"		119009	0.7			
	1-1/16"		119010	0.6			
	1-1/8"		119011	0.6			
	1-3/16"		119012	0.5			
	1-1/4"		119013	0.5			
2012	1/2"		119241	1.7	1/8 x 1/16	1/8 x 1/16	1/8 x 1/8
	9/16"		119242	1.7			
	5/8"		117087	1.7	3/16 x 3/32	3/16 x 3/32	3/16 x 3/16
	11/16"		119244	1.7			
	3/4"		117088	1.7			
	13/16"		119246	1.7			
	7/8"		117089	1.6			
	15/16"	119249	119248	1.6	1/4 x 1/8	1/4 x 1/8	1/4 x 1/4
	1"		117164	1.6			
	1-1/16"		119250	1.6			
	1-1/8"	117090	1.5				
	1-3/16"	119252	117165	1.5			
	1-1/4"	119253	117166	1.4			
	1-5/16"		119254	1.3	5/16 x 5/32	5/16 x 5/32	5/16 x 5/16
	1-3/8"		117091	1.2			
	1-7/16"	119256 119257	117167	1.2	3/8 x 3/16	3/8 x 3/16	3/8 x 3/8
	1-1/2"		117168	1.2			
	1-9/16"		119258	1.2			
	1-5/8"		117092	1.2			
	1-11/16"		117093	1.1			
	1-3/4"	117094	1.0				
	1-13/16"		119262	1.0	1/2 x 1/4	1/2 x 1/4	1/2 x 1/2
	1-7/8"		117095	0.9			
1-15/16" #		117169	0.9	1/2 x 3/16	1/2 x 1/4	1/2 x 7/16 Δ	
2" #		117170	0.9				
2-1/8" +		117177	0.9				
14MM		119664	1.7	5 x 2.3MM	5 x 3.0MM	5 x 5MM	
16MM		119665	1.7				

Δ Key furnished for these sizes only. + These sizes are steel. # Refer to torque capacity rating on this page.
If Service Factor of 2.0 or greater is required, consult DODGE.

TAPER-LOCK BUSHINGS TORQUE CAPACITY RATING

TL Bush Size	Torque Capacity Rating (in-lb)
1215	3550
2012	7150
2517	11600
3020	24000

PARA-FLEX GTL ACCESSORIES



TAPER-LOCK BUSHINGS

TL Bush Size	BORE	P/N Integral Key	P/N Keyway	WT.	Bushing Keyway	Shaft Keyway REF	Key Size REF
2012 (Cont)	18MM		119666	1.6	6 x 2.8MM	6 x 3.5MM	6 x 6MM
	19MM		119574	1.6			
	20MM		119607	1.6			
	22MM		119667	1.6			
	24MM		119608	1.5	8 X 3.3MM	8 X 4MM	8 X 7MM
	25MM		119609	1.5			
	28MM		119610	1.5			
	30MM		119611	1.4	10 X 3.3MM	10 X 5MM	10 X 8MM
	32MM		119612	1.4			
	35MM		119613	1.3			
	38MM		119614	1.3			
	40MM		119615	1.2	12 X 3.3MM	12 X 5MM	12 X 8MM
	42MM		119616	1.1			
	45MM		119617	1.0	14 X 3.8MM	14 X 5.5MM	14 X 9MM
48MM		119668	0.9				
2517	1/2"		119100	3.7	1/8 x 1/16	1/8 x 1/16	1/8 x 1/8
	5/8"		119102	3.6	3/16 x 3/32	3/16 x 3/32	3/16 x 3/16
	11/16"		119103	3.5			
	3/4"		119104	3.4			
	13/16"		119105	3.4			
	7/8"		119106	3.3			
	15/16"		119107	3.3	1/4 x 1/8	1/4 x 1/8	1/4 x 1/4
	1"		119108	3.3			
	1-1/16"		119109	3.2			
	1-1/8"		119110	3.2			
	1-3/16"		119111	3.2			
	1-1/4"		119112	3.2			
	1-5/16"		119113	3.1			
	1-3/8"		119114	3.1			
	1-7/16"	119144	119115	3.0	3/8 x 3/16	3/8 x 3/16	3/8 x 3/8
	1-1/2"		119116	2.9			
	1-9/16"		119117	2.9			
1-5/8"	119118		2.8				
1-11/16"	119119		2.8				
1-3/4"	119120		2.7				

If Service Factor of 2.0 or greater is required, consult DODGE.



TAPER-LOCK BUSHINGS

TL Bush Size	BORE	P/N Integral Key	P/N Keyway	WT.	Bushing Keyway	Shaft Keyway REF	Key Size REF
2517 (Cont)	1-13/16"	119123 119124	119121	2.6	1/2 x 1/4	1/2 x 1/4	1/2 x 1/2
	1-7/8"		119122	2.5			
	1-15/16"		117173	2.4			
	2"		117174	2.3			
	2-1/16"		119125	2.3			
	2-1/8"		117096	2.2			
	2-3/16"		117175	2.1			
	2-1/4"		117097	2.0			
	2-5/16"		119129	1.9	5/8 x 3/16	5/8 x 5/16	5/8 x 1/2 Δ
	2-3/8"		117098	1.9			
	2-7/16" #		117176	1.8			
	2-1/2" #		117099	1.8			
	2-5/8" +		117111	1.8			
	2-11/16"+	117115	1.8				
	14MM		119669	3.6	5 x 2.3MM	5 x 3.0MM	5 x 5MM
	16MM		119670	3.6			
	18MM		119671	3.5	6 x 2.8MM	6 x 3.5MM	6 x 6MM
	19MM		119672	3.4			
	20MM		119618	3.4			
	22MM		119619	3.3			
	24MM		119620	3.3			
	25MM	119621	3.2	8 X 3.3MM	8 X 4MM	8 X 7MM	
	28MM	119622	3.1				
	30MM	119623	3.1				
	32MM		119624	3	10 X 3.3MM	10 X 5MM	10 X 8MM
	35MM		119625	2.9			
	38MM		119626	2.9			
	40MM		119627	2.8	12 X 3.3MM	12 X 5MM	12 X 8MM
42MM	119628		2.6				
45MM		119629	2.5	14 X 3.8MM	14 X 5.5MM	14 X 9MM	
48MM		119630	2.4				
50MM		119640	2.3				
55MM		119641	2.0	16 X 4.3MM	16 X 6MM	16 X 10MM	
60MM		119642	1.7				
65MM		119643	1.4				

Δ Key furnished for these sizes only.

+ These sizes are steel.

Refer to torque capacity rating on this page.

If Service Factor of 2.0 or greater is required, consult DODGE.

TAPER-LOCK BUSHINGS TORQUE CAPACITY RATING

TL Bush Size	Torque Capacity Rating (in-lb)
1215	3550
2012	7150
2517	11600
3020	24000



TAPER-LOCK BUSHINGS

TL Bush Size	BORE	P/N Keyway	WT.	Bushing Keyway	Shaft Keyway REF	Key Size REF
3020	7/8"	117103	6.5	3/16 x 3/32	3/16 x 3/32	3/16 x 3/16
	15/16"	117101	6.5	1/4 x 1/8	1/4 x 1/8	1/4 x 1/4
	1"	117102	6.5			
	1-1/8"	117104	6.4			
	1-3/16"	117105	6.4			
	1-1/4"	117106	6.3			
	1-5/16"	117107	6.1	5/16 x 5/32	5/16 x 5/32	5/16 x 5/16
	1-3/8"	117108	6.0			
	1-7/16"	117109	6.0	3/8 x 3/16	3/8 x 3/16	3/8 x 3/8
	1-1/2"	117110	5.9			
	1-9/16"	117135	5.9			
	1-5/8"	117112	5.9			
	1-11/16"	117113	5.7			
	1-3/4"	117114	5.6			
	1-13/16"	117136	5.5	1/2 x 1/4	1/2 x 1/4	1/2 x 1/2
	1-7/8"	117116	5.4			
	1-15/16"	117117	5.3			
	2"	117118	5.2			
	2-1/16"	117119	5.0			
	2-1/8"	117120	5.0			
	2-3/16"	117121	4.9			
	2-1/4"	117122	4.8			
	2-5/16"	117137	4.6	5/8 x 5/16	5/8 x 5/16	5/8 x 5/8
	2-3/8"	117124	4.5			
	2-7/16"	117125	4.4			
	2-1/2"	117126	4.3			
	2-5/8"	117128	4.0			
	2-11/16"	117129	3.9			
	2-3/4"	117130	3.7			
	2-13/16"	117139	3.7	3/4 x 1/8	3/4 x 3/8	3/4 x 1/2 Δ
	2-7/8"	117132	3.6			
	2-15/16"#	117133	3.6			
3" #	117134	3.4				
3-1/8" +	117178	3.3	3/4 x 1/4	3/4 x 3/8	3/4 x 5/8 Δ	
3-3/16" +	117179	3.3				
3-1/4" +	117180	3.3				

Δ Key furnished for these sizes only.

+ These sizes are steel.

Refer to torque capacity rating on this page.

If Service Factor of 2.0 or greater is required, consult DODGE.

TAPER-LOCK BUSHINGS TORQUE CAPACITY RATING

TL Bush Size	Torque Capacity Rating (in-lb)
1215	3550
2012	7150
2517	11600
3020	24000



TAPER-LOCK BUSHINGS

TL Bush Size	BORE	P/N Keyway	WT.	Bushing Keyway	Shaft Keyway REF	Key Size REF
3020 (Cont)	24MM	119673	6.5	8 X 3.3MM	8 X 4MM	8 X 7MM
	25MM	119674	6.5			
	28MM	119675	6.4			
	30MM	119676	6.4			
	32MM	119677	6.3	10 X 3.3MM	10 X 5MM	10 X 8MM
	35MM	119678	6.0			
	38MM	119679	5.9			
	40MM	119680	5.9	12 X 3.3MM	12 X 5MM	12 X 8MM
	42MM	119681	5.8			
	45MM	119682	5.6	14 X 3.8MM	14 X 5.5MM	14 X 9MM
	48MM	119644	5.5			
	50MM	119645	5.2			
	55MM	119646	5.0	16 X 4.3MM	16 X 6MM	16 X 10MM
	60MM	119647	4.9	18 X 4.4MM	18 X 7MM	18 X 11MM
	65MM	119648	4.3	20 X 4.9MM	20 X 7.5MM	20 X 12MM
70MM	119649	3.7				
75MM	119650	3.5				

If Service Factor of 2.0 or greater is required, consult DODGE.

TAPER-LOCK BUSHINGS - REBORABLE

TL Bush Size	Sintered Steel Bore	P/N	Steel Bore	P/N	Stainless Steel Bore	P/N
1215	1/2"	119023	1/2"	119435	1/2"	119413
2012	1/2"	119272	1/2"	119422	1/2"	119417
2517	1/2"	119141	1"	119423	5/8"	119418
3020	7/8"	117147	1-7/16"	119430	7/8"	119419

NOTE: All reborable bushings are stocked without sawsplit to facilitate re-machining. Sawsplit must be made in bushing to allow it to compress for proper gripping of the shaft. Factory rebore and keyseat service as listed in MLP price book includes sawsplit.

PARA-FLEX ELEMENTS - PART NUMBERS

Element Size	Standard Part No.	Neoprene (1) Part No.	Cordless (2) Part No.	Weight (Lbs)
PX50	011105	011296	011285	0.7
PX60	011106	011297	011286	1.2
PX80	011108	011299	011288	2.2
PX100	011110	011301	011290	2.5

(1) Neoprene element ratings are the same as the standard natural rubber element range. (Green sticker or painted mark)

(2) Cordless elements have an average static torsional stiffness 25% of the standard element and approximately 25% of the torque rating. (White sticker or painted mark)



PARA-FLEX GRIP TIGHT

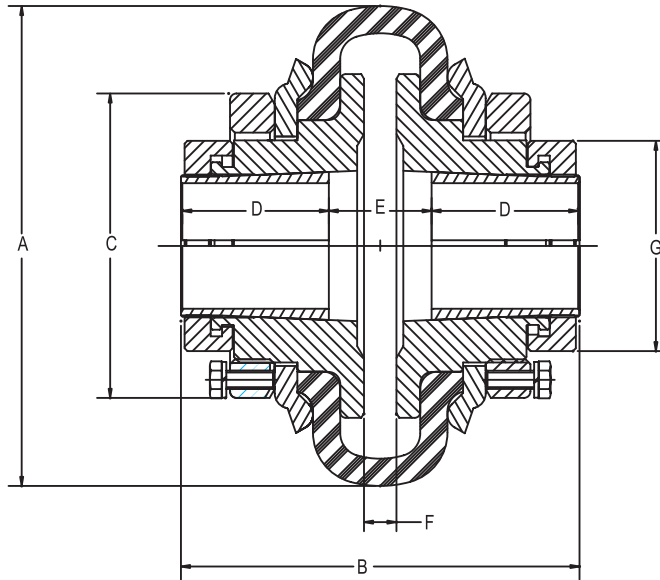

PARA-FLEX GT WITH GRIP TIGHT ADAPTER

COUPLING SIZE	GT SERIES	MAX. BORE	HP/100	TORQUE (IN-LBS) ⁽³⁾	MAX RPM	A DIA	B	C DIA	D	E	F	G DIA	WEIGHT (LBS.) ⁽¹⁾	INERTIA (LB-FT ²) ⁽²⁾
PX50GT	207	1-7/16	2.00	1260	4500	5.25	4.58	3.34	1.62	1.22	0.45	2.38	6.5	0.10
PX60GT	211	2-1/4	3.72	2340	4000	6.50	5.50	4.71	1.93	1.50	0.64	3.43	12.4	0.33
PX80GT	215	3	7.15	4502	3100	8.38	6.49	6.09	2.56	1.37	0.73	4.44	24.9	1.05

(1) WEIGHT OF COMPLETE COUPLING WITH BUSHING AT MAX BORE

(2) INERTIA OF COMPLETE COUPLING WITH BUSHING AT MAX BORE

(3) CHECK GT BUSHING TORQUE RATING ON PAGE PT-16. USE THE LOWER MAX. TORQUE RATING BETWEEN THE ELEMENT AND GT BUSHING

COUPLING SIZE	FLANGE ASSEMBLY PART NUMBER	ELEMENT PART NUMBER
PX50GT	000332	011105
PX60GT	000333	011106
PX80GT	000334	011108

COMPLETE COUPLING CONSISTS OF:

(2) GT FLANGE ASSEMBLIES

(2) GT ADAPTER ASSEMBLIES FROM PAGE PT-14

(1) ELEMENT



GT ADAPTER & LOCK NUT ASSEMBLIES

PXGT	Series	Shaft Size	Adapter Sleeve & Lock Nut Assembly			
			Part No.	Description		
50	207	RB	136432	AN-GT-07-008 REBORE		
		1/2"	136433	AN-GT-07-008		
		5/8"	136434	AN-GT-07-010		
		3/4"	136435	AN-GT-07-012		
		7/8"	136436	AN-GT-07-014		
		1"	136437	AN-GT-07-100		
		1-1/8"	136438	AN-GT-07-102		
		1-3/16"	136542	AN-GTM-07-103		
		1-1/4"	136528	AN-GT-07-104		
		1-3/8"	136591	AN-GT-07-106		
		1-7/16"	136529	AN-GT-07-107		
		30mm	129954	AN-GTM-07-30M		
		35mm	136556	AN-GT-07-35M		
		60	211	RB	136439	AN-GT-11-014 REBORE
				7/8"	136440	AN-GT-11-014
1"	136441			AN-GT-11-100		
1-1/8"	136442			AN-GT-11-102		
1-3/16"	136443			AN-GT-11-103		
1-1/4"	136444			AN-GT-11-104		
1-3/8"	136445			AN-GT-11-106		
1-7/16"	136446			AN-GT-11-107		
1-1/2"	136447			AN-GT-11-108		
1-5/8"	136448			AN-GT-11-110		
1-3/4"	136449			AN-GT-11-112		
1-7/8"	136450			AN-GT-11-114		
1-15/16"	136545			AN-GTM-11-115		
2	136600			AN-GTM-11-200		
2-1/8"	136451			AN-GT-11-202		
2-3/16"	136536			AN-GT-11-203		
2-1/4"	136537			AN-GT-11-204		
50mm	136566			AN-GTM-11-50M		
55mm	129950			AN-GT-11-55M		

PXGT	Series	Shaft Size	Adapter Sleeve & Lock Nut Assembly	
			Part No.	Description
80	215	RB	136453	AN-GT-15-104 REBORE
		1-1/4"	136454	AN-GT-15-104
		1-3/8"	136455	AN-GT-15-106
		1-7/16"	136456	AN-GT-15-107
		1-1/2"	136457	AN-GT-15-108
		1-5/8"	136458	AN-GT-15-110
		1-3/4"	136459	AN-GT-15-112
		1-7/8"	136460	AN-GT-15-114
		1-15/16"	136461	AN-GT-15-115
		2	136462	AN-GT-15-200
		2-1/8"	136463	AN-GT-15-202
		2-3/16"	136464	AN-GT-15-203
		2-1/4"	136465	AN-GT-15-204
		2-3/8"	136466	AN-GT-15-206
		2-7/16"	136467	AN-GT-15-207
		2-1/2"	136468	AN-GT-15-208
		2-11/16"	129937	AN-GTM-15-211
		2-7/8"	136469	AN-GT-15-214
		2-15/16"	136540	AN-GT-15-215
		3	129987	AN-GT-15-300
70mm	136569	AN-GTM-15-70M		
75mm	129953	AN-GT-15-75M		

PARA-FLEX ELEMENTS - PART NUMBERS

Element Size	Standard Part No.	Neoprene (1) Part No.	Cordless (2) Part No.	Weight (Lbs)
PX50	011105	011296	011285	0.7
PX60	011106	011297	011286	1.2
PX80	011108	011299	011288	2.2
PX100	011110	011301	011290	2.5

- (1) Neoprene element ratings are the same as the standard natural rubber element range. (Green sticker or painted mark)
- (2) Cordless elements have an average static torsional stiffness 25% of the standard element and approximately 25% of the torque rating. (White sticker or painted mark)



SELECTION CHART FOR ENGLISH BORE SIZES

Coupling Size	Shaft Size (Inches)	Flange Type			Element Rated Torque (in-lbs)	Maximum GT Adapter Torque (in-lbs)	Max RPM
		GTL	GT	GFB			
PX50	RB	X	X				
	1/2"	X	R		777 [^]		
	9/16"	X					
	5/8"	X	R		971 [^]		
	11/16"	X					
	3/4"	X	R		1166 [^]		
	13/16"	X					
	7/8"	X	R		1360		
	15/16"	X					
	1"	X	R		1554		
	1-1/16"	X					
	1-1/8"	X	R		1749		
	1-3/16"	X	X		1846		
	1-1/4"	X	X		1943		
	1-3/8"		X		2137		
	1-7/16"		X		2234		
	1-9/16"			X			
	1-5/8"			X			
	1-11/16"			X			
	1-3/4"			X			
1-13/16"			X				
1-7/8"			X				
PX60	RB	X	X				
	1/2"	X					
	9/16"	X					
	5/8"	X					
	11/16"	X					
	3/4"	X					
	13/16"	X					
	7/8"	X	R		1403 [^]		
	15/16"	X					
	1"	X	R		1604 [^]		
	1-1/16"	X					
	1-1/8"	X	R		1805 [^]		
	1-3/16"	X	R		1905 [^]		
	1-1/4"	X	R		2005 [^]		
	1-5/16"	X					
	1-3/8"	X	R		2206 [^]		
	1-7/16"	X	R		2306 [^]		
	1-1/2"	X	R		2406		
	1-9/16"	X					
	1-5/8"	X	R		2607		
1-11/16"	X						
1-3/4"	X	R		2807			

Coupling Size	Shaft Size (Inches)	Flange Type			Element Rated Torque (in-lbs)	Maximum GT Adapter Torque (in-lbs)	Max RPM
		GTL	GT	GFB			
PX60 (cont)	1-13/16"	X					
	1-7/8"	X	R			3008	
	1-15/16"	X	X			3108	
	2"	X	X			3208	
	2-1/8"	X	R			3409	
	2-3/16"		X			3509	
	2-1/4"		X			3609	
	2-3/8"			X			
	2-7/16"			X			
	2-1/2"			X			
	2-5/8"			X			
	2-11/16"			X			
	2-3/4"			X			
	PX80	RB	X	X			
		1/2"	X				
5/8"		X					
11/16"		X					
3/4"		X					
13/16"		X					
7/8"		X					
15/16"		X					
1"		X					
1-1/16"		X					
1-1/8"		X					
1-3/16"		X					
1-1/4"		X	R		3448 [^]		
1-5/16"		X					
1-3/8"		X	R		3793 [^]		
1-7/16"		X	R		3965 [^]		
1-1/2"		X	R		4138 [^]		
1-9/16"		X					
1-5/8"		X	R		4483 [^]		
1-11/16"		X					
1-3/4"	X	R		4828			
1-13/16"	X						
1-7/8"	X	R		5173			
1-15/16"	X	R		5345			
2"	X	R		5517			
2-1/16"	X						
2-1/8"	X	R		5862			
2-3/16"	X	R		6034			
2-1/4"	X	R		6207			
2-5/16"	X						
2-3/8"	X	R		6552			

NOTE: Bore sizes for flanges represented with a blue "R" are reborable sizes

[^] Sizes where the GT capacity is below the element capacity



SELECTION CHART FOR ENGLISH BORE SIZES

Coupling Size	Shaft Size (Inches)	Flange Type			Element Rated Torque (in-lbs)	Maximum GT Adapter Torque (in-lbs)	Max RPM
		GTL	GT	GFB			
PX80 (cont)	2-7/16"	X	R		4502	6724	3100
	2-1/2"	X	R			6897	
	2-5/8"	X					
	2-11/16"	X	X			7414	
	2-7/8"		R			7931	
	2-15/16"		X			8104	
	3"		X			8276	
	3-1/8"			X			
	3-3/16"			X			
	3-1/4"			X			
	3-3/8"			X			
	3-7/16"			X			
	3-1/2"			X			

SELECTION CHART FOR METRIC BORE SIZES

Coupling Size	Shaft Size (inches)	Flange Type			Element Rated Torque (in-lbs)	Maximum GT Adapter Torque (in-lbs)	Max RPM
		GTL	GT	GFB			
PX50	RB	X	X		1260		4500
	30 mm		X			1836	
	35 mm		X			2142	
PX60	RB	X	X		2340		4000
	14 mm	X					
	16 mm	X					
	18 mm	X					
	19 mm	X					
	20 mm	X					
	22 mm	X					
	24 mm	X					
	25 mm	X					
	28 mm	X					
	30 mm	X					
	32 mm	X					
	35 mm	X					
	38 mm	X					
	40 mm	X					
	42 mm	X					
	45 mm	X					
	48 mm	X					
	50 mm			X			
55 mm			X		3474		

Coupling Size	Shaft Size (inches)	Flange Type			Element Rated Torque (in-lbs)	Maximum GT Adapter Torque (in-lbs)	Max RPM
		GTL	GT	GFB			
PX80	RB	X	X		4502		3100
	14 mm	X					
	16 mm	X					
	18 mm	X					
	19 mm	X					
	20 mm	X					
	22 mm	X					
	24 mm	X					
	25 mm	X					
	28 mm	X					
	30 mm	X					
	32 mm	X					
	35 mm	X					
	38 mm	X					
	40 mm	X					
	42 mm	X					
	45 mm	X					
	48 mm	X					
	50 mm	X					
	55 mm	X					
	60 mm	X					
65 mm	X						
70 mm			X		7602		
75 mm			X		8146		

NOTE: Bore sizes for flanges represented with a blue "R" are reborable sizes



SELECTION PROCEDURE:

Step 1: Obtain required service factor from Service Factor Table1 on pages PT-18 through PT-19 based on the application.

Step 2: Determine torque required for the application by using the following formula:

$$\text{Torque (in-lb)} = \frac{63025 \times \text{HP} \times \text{SF}}{\text{Coupling RPM}}$$

$$\text{Torque (N•m)} = \frac{60000 \times \text{Power (kw)} \times \text{SF}}{\text{Coupling RPM} \times 2}$$

(Metric)

Where

HP = Horsepower

SF = Service Factor from Step 1

Coupling RPM = Rotation Speed of Coupling, Revolutions Per Minute

Step 3: From the selection charts beginning on PT-15, find an Element Rating equal to or greater than the application torque calculated in step 2. Note Coupling size from left hand column.

Step 4: Check maximum RPM capability on right-hand column.

Step 5: Check maximum bore capacity. If maximum bore is exceeded, move to larger size with adequate bore, but be sure maximum RPM of the coupling is not exceeded.

Step 6: If the GT Adapter system is utilized then ensure the keyless torsional holding power exceeds the application demands. From the application tables listed above, ensure the **Maximum Adapter Torque** for the shaft size exceeds the application torque that was calculated in step 2.

^ Sizes where the GT capacity is below the element capacity.

NOTE: If system peak torque is known and is non-reversing, start at Step 3. If system peak torque is known and reversing, multiply by 2.0 and start at Step 3.

Bore sizes for flanges represented with a blue 'R' are reborable sizes.



TABLE 1 – SERVICE FACTORS Δ

APPLICATION (READ FOOTNOTES)	PARA-FLEX
AGITATORS	
Paddle or Propeller (Vert. or Horiz.)	1.00
Screw	1.00
BLOWERS	
Centrifugal	1.00
Lobe	1.50
Vane	1.00
BREWING & DISTILLING	
Bottling Machinery, Brew Kettle, Cooker (Continuous Duty), Mash Tub	1.00
Scale Hopper-Frequent Starting Peaks	1.50
CAN FILLING MACHINE	1.00
CAR DUMPER	1.50
CAR PULLER	1.50
CLARIFIER	1.00
CLASSIFIER	1.00
CLAY-WORKING MACHINES	
Brick Press, Briquette Mach., Clay Work-ing Mach., Pug Mill	1.50
COMPRESSORS**	
Centrifugal. Lobe, Screw	1.00
Lobe, Rotary	2.00
Reciprocating	
1 cylinder - single acting	3.50
1 cylinder - double acting	3.00
2 cylinder- single acting	3.00
2 cylinder - double acting	2.50
3 cl. or more - single acting	2.50
3 cl. or more - double acting	2.00
CONVEYORS	
Apron, Assembly, Belt, Chain, Flight, Oven	1.00
Reciprocating	2.50
Screw	1.00
CRANES AND HOISTS	
Main Hoist-Medium Duty	1.50
Main Hoist-Heavy Duty	2.00
Skip Hoist, Travel Motion, Trolley Motion, Slope	1.50
CRUSHERS	
Cane	2.00
Gyratory	2.50
DREDGES	
Cable Reel, Screen Drive, Stacker	1.50
Conveyor	1.50
Cutter Head Drive, Jig Drive	2.50
Pump, Utility Winch	1.50
DYNAMOMETER	1.00
ELEVATORS	
Bucket, Freight	2.00

** Add 0.5 to factor if without flywheel

APPLICATION (READ FOOTNOTES)	PARA-FLEX
EXCITER	1.00
FANS	
Centrifugal	1.00
Cooling Tower	2.00
Heavy Duty (Forced Draft) and Induced Draft	1.50
Light	1.00
Propeller Indoor	1.50
FOOD INDUSTRY	
Beet Slicer	1.50
Cereal Cooker	1.00
Dough Mixer, Meat Grinder	1.50
GENERATORS	
Even Load	1.00
Hoist or Railway Service	1.50
Welder Load	2.00
GRIZZLY	2.00
KILN	2.00
LAUNDRY MACHINES	
Tumbler Washer	2.00
LINE SHAFTS	
Driving Processing Machinery	1.00
Light	1.00
LUMBER INDUSTRY	
Band Resaw	1.50
Circular Resaw	1.50
Edger Head Rig, Hog, Log Haul	2.00
Planer	1.50
Rolls Non-Reversing	1.50
Rolls Reversing	2.00
Sawdust Conveyor	1.00
Slab Conveyor	1.50
Sorting Table	1.50
MACHINE TOOLS	
Auxiliary	1.00
Main Drive	1.50
Notching Press, Planer (Reversing), Plate Planer, Punch Press	1.50
Traverse	1.00
METAL FORMING MACHINES	
Draw Bench, Carriage, Main Drive, Extruder,	2.00
Wire Drawing, Flattening Machine	2.00
MILLS Rotary Type	
Ball or Pebble direct or	2.50
on LS Shaft Gear Reducer	2.50
on HS Shaft Gear Reducer	2.00
Dryer and Cooler	1.50
Rod or Tube direct or	2.50
on LS Shaft Gear Reducer	2.50
on HS Shaft Gear Reducer	2.00
Tumbling Barrel	1.50



TABLE 1 – SERVICE FACTORS Δ (cont)

APPLICATION (READ FOOTNOTES)	PARA- FLEX
MIXERS	
Concrete (Continuous or intermittent)	1.50
Muller-Simpson type	1.50
OIL INDUSTRY	
Chiller	1.00
Oil Well Pumping (Not over 150% peak torque)	2.00
Paraffin Filter Press	1.50
PAPER MILLS	
Agitator	1.00
Barking Drum	2.50
Beater and Pulper	1.50
Bleacher	1.00
Calender	2.00
Chipper	3.00
Couch Cylinder Dryer	1.50
Felt Stretcher	1.00
Fourdrinier	1.50
Jordan	2.00
Press	2.00
Pulp Grinder	2.00
Stock Chest	1.50
Stock Pump	
Reciprocating	2.00
Rotary	1.50
Suction Roll	2.00
Winder	1.50
PARAFFIN FILTER PRESS	1.50
PRINTING PRESS	1.50
PROPELLER Marine	1.50
PULLERS	
Barge Hall	2.50
PULVERIZERS	
Hammermill-Light Duty	1.50
Hammermill-Heavy Duty	2.00
Hog	2.00
Roller	1.50
PUMPS	
For Stock Pumps See Paper Mills	
Centrifugal	1.00
Descaling Gear Type	1.50
Oil Well Pumping (Not over 150% peak torque)	2.00
Rotary -other than ear	1.50
Reciprocating	
1 cylinder-single acting	2.50
1 cylinder-double acting	2.00
2 cylinder-single acting	2.00
2 cylinder-double acting	1.50
3 cylinder or more	1.50

APPLICATION (READ FOOTNOTES)	PARA- FLEX
RUBBER INDUSTRY	
Banbury Mixer	2.50
Calender	2.00
Cracker Mixing Mill Plasticator	2.50
Refiner, Sheeter, Tire-Building Machine	2.00
Tire and Tube Press Opener Based on Peak Torque	1.00
Tuber and Strainer	1.50
Warming Mill	2.00
Washer	2.50
SCREENS	
Air Washing	1.00
Coal and Sand Rotary	1.50
Vibrating	2.50
Water	1.00
SEWAGE DISPOSAL EQUIPMENT	1.00
SHOVEL	2.00
SHREDDER	1.50
STEEL INDUSTRY	
Cold Mills	
Coiler up or down	1.50
Strip, Temper	2.00
Hot Mills	
Coiler up or down, Edger Drive	1.50
Feed Roll Blooming	3.00
Roughing Mill Delivery	3.00
Non-reversing, Sheet Strip	3.00
Rod Mill	2.50
Soaking Pit Cover Drive Lift	3.00
Soaking Pit Cover Drive Travel	3.00
STEERING GEAR	1.00
STOKER	
TEXTILE MILLS	
Batcher	1.00
“Calender, Card Machine, D Can”	1.50
Dyeing Machine	1.00
Loom	1.50
Mangel, Napper, Soaper	1.00
Spinner, Tenter Frame	1.50
WINDLASS	1.50
WOODWORKING MACHINES	1.00

Δ The service factors listed are intended only as a general guide. Where substantial shock occurs or starting and stopping is frequent as on some “inching” drives and on some reversing drives or where the power source is an internal combustion engine with less than four cylinders-Consult DODGE. Where torsional vibrations occur as in, for example, internal combustion engine or reciprocating compressor or pump applications, check the coupling stiffness for the possible development of damaging large amplitude vibrations. A complete system torsional analysis may be necessary.



TABLE 2-DRIVER SERVICE FACTOR ADDERS Δ

Type of Coupling	Electric Motor Std. Torque	High Torque Motors	Turbines	Reciprocating Engine Number of Cylinders				
				12 or More	8 to 11	6 to 7	4 to 5	Less than 4
PARA-FLEX	0.00	0.00	0.00	0.00	0.50	0.50	0.50	◆

SYSTEM SERVICE FACTOR CALCULATION
 To determine the system service factor, the driver service factor adder (Table 2) must be added to the driven service factor. (Table 1) Example:
 Determine the system service factor for a PARA-FLEX coupling used to couple a barking drum and a six-cylinder diesel engine.

Driven S.F. + Driver S.F. Adder = System S.F.
 $2.5 + .5 = 3.0$

Δ The service factors listed are intended only as a general guide. Where substantial shock occurs or starting and stopping is frequent as on some "inching" drives and on some reversing drives or where the power source is an internal combustion engine with less than four cylinders-Consult DODGE. Where torsional vibrations occur as in, for example, internal combustion engine or reciprocating compressor or pump applications, check the coupling stiffness for the possible development of damaging large amplitude vibrations. A complete system torsional analysis may be necessary.

◆ CONSULT DODGE FOR SELECTION ASSISTANCE

ELASTOMER COMPATIBILITY

Ratings: 1-Minor Effect / 2-Moderate Effect / 3-Severe Effect

Substance	Nat. Rubber	Neoprene
Acetic Acids	2	1
Acetic Anhydride	2	1
Alcohols, Monohydric	2	1
Ammonia Anhydrous	3	1
ASTM A Oils	3	1
Animal Fats	3	2
Benzene	3	3
Carbonic Acid	3	2
Calcium Bisulfite	2	1
Chloracetone	2	2
Chloroacetic Acid	2	1
Copper Sulphate	2	1
Corn Oil	2	2
Diesel Oil	3	2
Fuel Oil	3	2
Gasoline	2	2

Substance	Nat. Rubber	Neoprene
Hydrobromic Acid (40%)	1	2
Kerosene	3	2
Lacquers	3	3
Lead Sulfamate	2	1
Mineral Oil	3	2
Naphtha	3	2
Nickel Chloride	1	2
Nitric Acid (10%)	1	2
Ozone	3	2
Petroleum (<250°F)	3	2
Potassium Dichromate	2	1
Salt Water	1	2
Silicone Oils	1	1
Sulfuric Acid (Conc.)	3	3
Vinegar	2	1
Zinc Sulfate	2	1

TORSIONAL STIFFNESS

PARA-FLEX	
Size	In-Lbs/Degree (1)
PX50	224
PX60	414
PX80	876
PX100	1530

(1) Values are nominal and may vary +/- 20%. To convert static values to approximate dynamic values, multiply the static values by 1.2

PART NUMBER INDEX



000251.....	PT-6	000336.....	PT-7	117087.....	PT-8	117164.....	PT-8
000252.....	PT-6	000337.....	PT-7	117088.....	PT-8	117165.....	PT-8
000253.....	PT-6	000359.....	PT-5	117089.....	PT-8	117166.....	PT-8
000254.....	PT-6	000360.....	PT-5	117090.....	PT-8	117167.....	PT-8
000255.....	PT-6	000361.....	PT-5	117091.....	PT-8	117168.....	PT-8
000256.....	PT-6	000362.....	PT-5	117092.....	PT-8	117169.....	PT-8
000257.....	PT-6	000363.....	PT-5	117093.....	PT-8	117170.....	PT-8
000258.....	PT-6	000364.....	PT-5	117094.....	PT-8	117173.....	PT-10
000259.....	PT-6	000365.....	PT-5	117095.....	PT-8	117174.....	PT-10
000260.....	PT-6	000366.....	PT-5	117096.....	PT-10	117175.....	PT-10
000261.....	PT-6	000367.....	PT-5	117097.....	PT-10	117176.....	PT-10
000262.....	PT-6	000368.....	PT-5	117098.....	PT-10	117177.....	PT-8
000263.....	PT-6	000369.....	PT-5	117099.....	PT-10	117178.....	PT-11
000264.....	PT-6	000370.....	PT-5	117101.....	PT-11	117179.....	PT-11
000265.....	PT-6	000371.....	PT-5	117102.....	PT-11	117180.....	PT-11
000266.....	PT-6	000372.....	PT-5	117103.....	PT-11	119001.....	PT-8
000267.....	PT-6	000373.....	PT-5	117104.....	PT-11	119002.....	PT-8
000268.....	PT-6	000374.....	PT-5	117105.....	PT-11	119003.....	PT-8
000269.....	PT-6	000375.....	PT-5	117106.....	PT-11	119004.....	PT-8
000270.....	PT-6	000376.....	PT-5	117107.....	PT-11	119005.....	PT-8
000271.....	PT-6	000377.....	PT-7	117108.....	PT-11	119006.....	PT-8
000272.....	PT-6	000378.....	PT-7	117109.....	PT-11	119007.....	PT-8
000273.....	PT-6	000379.....	PT-7	117110.....	PT-11	119008.....	PT-8
000274.....	PT-6	000380.....	PT-5	117111.....	PT-10	119009.....	PT-8
000275.....	PT-6	000381.....	PT-5	117112.....	PT-11	119010.....	PT-8
000276.....	PT-7	011105... PT-6, PT-12,		117113.....	PT-11	119011.....	PT-8
000277.....	PT-7		PT-14	117114.....	PT-11	119012.....	PT-8
000302.....	PT-5	011106... PT-6, PT-12,		117115.....	PT-10	119013.....	PT-8
000303.....	PT-5		PT-14	117116.....	PT-11	119023.....	PT-12
000304.....	PT-5	011108... PT-6, PT-12,		117117.....	PT-11	119100.....	PT-9
000305.....	PT-5		PT-14	117118.....	PT-11	119102.....	PT-9
000306.....	PT-5	011110... PT-6, PT-12,		117119.....	PT-11	119103.....	PT-9
000307.....	PT-5		PT-14	117120.....	PT-11	119104.....	PT-9
000308.....	PT-5	011285... PT-6, PT-12,		117121.....	PT-11	119105.....	PT-9
000309.....	PT-5		PT-14	117122.....	PT-11	119106.....	PT-9
000310.....	PT-5	011286... PT-6, PT-12,		117124.....	PT-11	119107.....	PT-9
000311.....	PT-5		PT-14	117125.....	PT-11	119108.....	PT-9
000312.....	PT-5	011288... PT-6, PT-12,		117126.....	PT-11	119109.....	PT-9
000313.....	PT-5		PT-14	117128.....	PT-11	119110.....	PT-9
000314.....	PT-5	011290... PT-6, PT-12,		117129.....	PT-11	119111.....	PT-9
000315.....	PT-5		PT-14	117130.....	PT-11	119112.....	PT-9
000316.....	PT-5	011296... PT-6, PT-12,		117132.....	PT-11	119113.....	PT-9
000317.....	PT-5		PT-14	117133.....	PT-11	119114.....	PT-9
000318.....	PT-5	011297... PT-6, PT-12,		117134.....	PT-11	119115.....	PT-9
000319.....	PT-5		PT-14	117135.....	PT-11	119116.....	PT-9
000332.....	PT-13	011299... PT-6, PT-12,		117136.....	PT-11	119117.....	PT-9
000333.....	PT-13		PT-14	117137.....	PT-11	119118.....	PT-9
000334.....	PT-13	011301... PT-6, PT-12,		117139.....	PT-11	119119.....	PT-9
000335.....	PT-7		PT-14	117147.....	PT-12	119120.....	PT-9



119121.....	PT-10	119627.....	PT-10	136442.....	PT-14
119122.....	PT-10	119628.....	PT-10	136443.....	PT-14
119125.....	PT-10	119629.....	PT-10	136444.....	PT-14
119129.....	PT-10	119630.....	PT-10	136445.....	PT-14
119141.....	PT-12	119640.....	PT-10	136446.....	PT-14
119241.....	PT-8	119641.....	PT-10	136447.....	PT-14
119242.....	PT-8	119642.....	PT-10	136448.....	PT-14
119244.....	PT-8	119643.....	PT-10	136449.....	PT-14
119246.....	PT-8	119644.....	PT-12	136450.....	PT-14
119248.....	PT-8	119645.....	PT-12	136451.....	PT-14
119249.....	PT-8	119646.....	PT-12	136453.....	PT-14
119250.....	PT-8	119647.....	PT-12	136454.....	PT-14
119252.....	PT-8	119648.....	PT-12	136455.....	PT-14
119253.....	PT-8	119649.....	PT-12	136456.....	PT-14
119254.....	PT-8	119650.....	PT-12	136457.....	PT-14
119256.....	PT-8	119664.....	PT-8	136458.....	PT-14
119257.....	PT-8	119665.....	PT-8	136459.....	PT-14
119258.....	PT-8	119666.....	PT-9	136460.....	PT-14
119262.....	PT-8	119667.....	PT-9	136461.....	PT-14
119272.....	PT-12	119668.....	PT-9	136462.....	PT-14
119413.....	PT-12	119669.....	PT-10	136463.....	PT-14
119417.....	PT-12	119670.....	PT-10	136464.....	PT-14
119418.....	PT-12	119671.....	PT-10	136465.....	PT-14
119419.....	PT-12	119672.....	PT-10	136466.....	PT-14
119422.....	PT-12	119673.....	PT-12	136467.....	PT-14
119423.....	PT-12	119674.....	PT-12	136468.....	PT-14
119430.....	PT-12	119675.....	PT-12	136469.....	PT-14
119435.....	PT-12	119676.....	PT-12	136528.....	PT-14
119574.....	PT-9	119677.....	PT-12	136529.....	PT-14
119607.....	PT-9	119678.....	PT-12	136536.....	PT-14
119608.....	PT-9	119679.....	PT-12	136537.....	PT-14
119609.....	PT-9	119680.....	PT-12	136540.....	PT-14
119610.....	PT-9	119681.....	PT-12	136542.....	PT-14
119611.....	PT-9	119682.....	PT-12	136545.....	PT-14
119612.....	PT-9	129937.....	PT-14	136556.....	PT-14
119613.....	PT-9	129950.....	PT-14	136566.....	PT-14
119614.....	PT-9	129953.....	PT-14	136569.....	PT-14
119615.....	PT-9	129954.....	PT-14	136591.....	PT-14
119616.....	PT-9	129987.....	PT-14	136600.....	PT-14
119617.....	PT-9	136432.....	PT-14		
119618.....	PT-10	136433.....	PT-14		
119619.....	PT-10	136434.....	PT-14		
119620.....	PT-10	136435.....	PT-14		
119621.....	PT-10	136436.....	PT-14		
119622.....	PT-10	136437.....	PT-14		
119623.....	PT-10	136438.....	PT-14		
119624.....	PT-10	136439.....	PT-14		
119625.....	PT-10	136440.....	PT-14		
119626.....	PT-10	136441.....	PT-14		

Blank

Blank



World Headquarters

P.O. Box 2400, Fort Smith, AR 72902-2400 U.S.A., Ph: (1) 479.646.4711, Fax (1) 479.648.5792, International Fax (1) 479.648.5895

Baldor - Dodge

6040 Ponders Court, Greenville, SC 29615-4617 U.S.A., Ph: (1) 864.297.4800, Fax: (1) 864.281.2433

www.baldor.com

© Baldor Electric Company
CA4000GSUP

All Rights Reserved. Printed in USA.
11/08 TCP 10000